

Quick Start Guide: Emerson FB1100 Flow Computer



Device Safety Considerations

- **Reading these Instructions**

Before operating the device, read these instructions carefully and understand their safety implications. In some situations, improperly using this device may result in damage or injury. Keep this manual in a convenient location for future reference. Note that these instructions may not cover all details or variations in equipment or cover every possible situation regarding installation, operation, or maintenance. Should problems arise that are not covered sufficiently in the text, immediately contact Customer Support for further information.
- **Protecting Operating Processes**

A failure of this device – for whatever reason -- may leave an operating process without appropriate protection and could result in possible damage to property or injury to persons. To protect against this, you should review the need for additional backup equipment or provide alternate means of protection (such as alarm devices, output limiting, fail-safe valves, relief valves, emergency shutoffs, emergency switches, etc.). Contact Remote Automation Solutions for additional information.
- **Returning Equipment**

If you need to return any equipment to Remote Automation Solutions, it is your responsibility to ensure that the equipment has been cleaned to safe levels, as defined and/or determined by applicable federal, state and/or local law regulations or codes. You also agree to indemnify Remote Automation Solutions and hold Remote Automation Solutions harmless from any liability or damage which Remote Automation Solutions may incur or suffer due to your failure to ensure device cleanliness.
- **Grounding Equipment**

Ground metal enclosures and exposed metal parts of electrical instruments in accordance with OSHA rules and regulations as specified in *Design Safety Standards for Electrical Systems*, 29 CFR, Part 1910, Subpart S, dated: April 16, 1981 (OSHA rulings are in agreement with the National Electrical Code). You must also ground mechanical or pneumatic instruments that include electrically operated devices such as lights, switches, relays, alarms, or chart drives.
- **Protecting from Electrostatic Discharge (ESD)**

This device contains sensitive electronic components which be damaged by exposure to an ESD voltage. Depending on the magnitude and duration of the ESD, it can result in erratic operation or complete failure of the equipment. Ensure that you correctly care for and handle ESD-sensitive components.

System Training

A well-trained workforce is critical to the success of your operation. Knowing how to correctly install, configure, program, calibrate, and trouble-shoot your Emerson equipment provides your engineers and technicians with the skills and confidence to optimize your investment. Remote Automation Solutions offers a variety of ways for your personnel to acquire essential system expertise. Our full-time professional instructors can conduct classroom training at several of our corporate offices, at your site, or even at your regional Emerson office. You can also receive the same quality training via our live, interactive Emerson Virtual Classroom and save on travel costs. For our complete schedule and further information, contact the Remote Automation Solutions Training Department at 800-338-8158 or email us at education@emerson.com.

Safety First!

Never perform the installation/setup activities described in this document in a hazardous area. Ensure the area is non-hazardous.

DANGER

EXPLOSION HAZARD: Never remove end cap(s) in a hazardous location. Removing end cap(s) in a hazardous location could result in an explosion.

DANGER

EXPLOSION HAZARD: Ensure the area in which you perform this operation is non-hazardous. Performing this operation in a hazardous area could result in an explosion.

Important

Only use batteries supplied with the flow computer or sold by Emerson as spare parts for this flow computer. If you substitute a battery you obtain elsewhere you will void your certification unless it is the identical part from the same manufacturer as that supplied with the flow computer from Emerson.

DANGER

EXPLOSION HAZARD - Substitution of any components may impair suitability for Class I, Division 1 or Class I, Division 2.

DANGER

EXPLOSION HAZARD - Do not disconnect equipment unless power has been removed or the area is known to be non-hazardous.

Tools Required

Certain tools and equipment are required for installing and servicing the flow computer.

Table 1: Required Tools

Tool	Use
Torque wrench	For bolting/mounting the flow computer
2.5 mm hexagonal wrench	For manipulating rotation set screw
3 mm hexagonal wrench	For screw for M4 x 0.7 end cap retaining clamp (ATEX required)
9/16 in hexagonal wrench	For installing/removing ¾ in NPT conduit plugs
1 1/16 in combination wrench	For installing/removing ¾ in NPT to M20 thread reducer (ATEX required)
High-wattage soldering iron and solder	For tinning ground connection wire
#1 Phillips-head screwdriver	For screws on HMI module
#2 Phillips-head screwdriver	For screws on other modules and boards
1/8 inch flat-head screwdriver	For 5.08 mm pitch terminal block connections
Laptop PC running Field Tools with FBxConnect configuration software	For software configuration

Removing/Replacing the Retaining Clamp

For flameproof ATEX/IEC applications, each end cap includes a retaining clamp which screws down to prevent the end cap from being unscrewed.

Front End Cap with Retaining Clamp Fitted

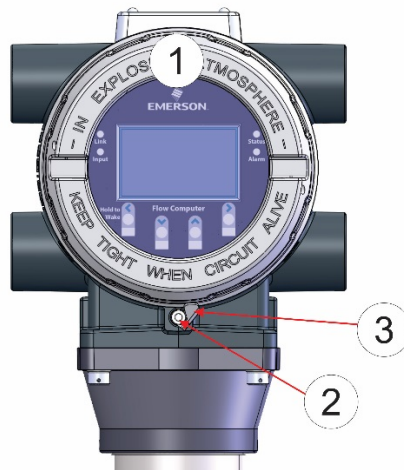

- 1 End Cap
 - 2 Screw
 - 3 Retaining Clamp
-

Retaining Clamp in Place

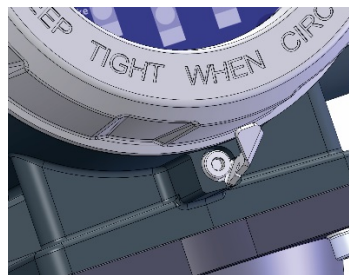

To loosen or tighten the screw, use a 3mm hexagonal wrench. When tightening, torque to 12 in-lbs (1.4 N m).

Retaining Clamp and Screw



Removing the Front or Rear End Cap

The flow computer includes two threaded end caps (covers). The front end cap includes a window for viewing the HMI module, while the rear end cap provides access to the terminal plate for power and I/O wiring.

⚠ DANGER

EXPLOSION HAZARD: Never remove end cap(s) in a hazardous location. Removing end cap(s) in a hazardous location could result in an explosion

1. Remove the retaining clamp (if present). Grasp the end cap (front or rear).

Note

If you need more leverage to open or close an end cap than you can get with your hand, you can place a long screwdriver or other appropriate tool across the two notches in the end cap to act as a pry bar:



2. Unscrew the end cap turning it counter-clockwise until the end cap comes off. Set it aside in a safe location.

Front End Cap



Removing Front End Cap



Rear End Cap



Removing Rear End Cap



Replacing the Front or Rear End Cap

DANGER

EXPLOSION HAZARD: Never remove end cap(s) in a hazardous location. Removing end cap(s) in a hazardous location could result in an explosion

1. Grasp the end cap (front or rear).
2. Carefully align the end cap threads with the threads of the enclosure.

Important

When replacing the rear end cap, ensure wires connecting to the terminal plate do not get crimped or caught between the end cap threads and the enclosure.

3. Screw the end cap clockwise (eight full turns) until it is tightly sealed to the enclosure.
4. Replace the retaining clamp (if applicable).

Bolting Considerations

DANGER

EXPLOSION HAZARD: Ensure the area in which you perform this operation is non-hazardous. Performing this operation in a hazardous area could result in an explosion.

If the flow computer installation requires assembly of a process flange, manifold, or flange adapters, follow these assembly guidelines to ensure a tight seal for optimal performance characteristics of the flow computer.

Only use bolts supplied with the flow computer or sold by Emerson as spare parts. Refer to figures below for common flow computer assemblies with the bolt length required for proper flow computer installation.

Note

For all other manifolds, contact your Emerson Local Business Partner (LBP).

Bolts are typically carbon steel or stainless steel. Confirm the material by viewing the markings on the head of the bolt and referencing [Table 2](#). If bolt material is not shown in the table, contact your local Emerson representative for more information.

Transmitter with coplanar flange

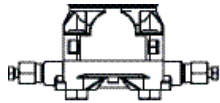

4 x 1.75 in (44 mm)

Transmitter with coplanar flange and optional flange adapters

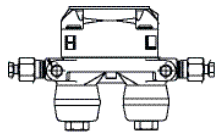

4 X 2.88 in (73 mm)

Transmitter with coplanar flange and optional flange adapters

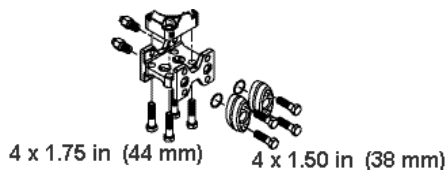







4 x 1.75 in (44 mm)

4 x 1.50 in (38 mm)

Use the following bolt installation procedure:

1. Carbon steel bolts do not require lubrication. Stainless steel bolts are factory-coated with a lubricant to ease installation. Do not apply any additional lubricant when installing either type of bolt.
2. Finger-tighten the bolts.
3. Torque the bolts to the **initial** torque value using a crossing pattern. See [Table 2](#) for initial torque value.
4. Torque the bolts to the **final** torque value using the same crossing pattern. See [Table 2](#) for final torque value.
5. Verify that the flange bolts protrude through the sensor module before applying pressure.

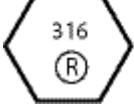
Table 2: Torque Values for the Flange and Flange Adapter Bolts

Bolt material	Head markings	Initial torque	Final torque
Carbon Steel (CS)	 	300 in. -lbs. (33.9 N m)	650 in. -lbs. (73.4 N m)
Stainless Steel (SST)	  	150 in. -lbs. (16.9 N m)	300 in. -lbs. (33.9 N m)
	  		

Proper Bolt Installation

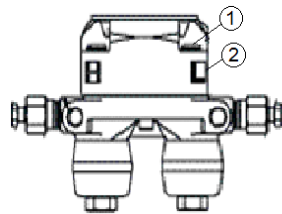

- 1 Bolt
- 2 Sensor module

Coplanar Mounting Kit

⚠ DANGER

EXPLOSION HAZARD: Ensure the area in which you perform this operation is non-hazardous. Performing this operation in a hazardous area could result in an explosion.

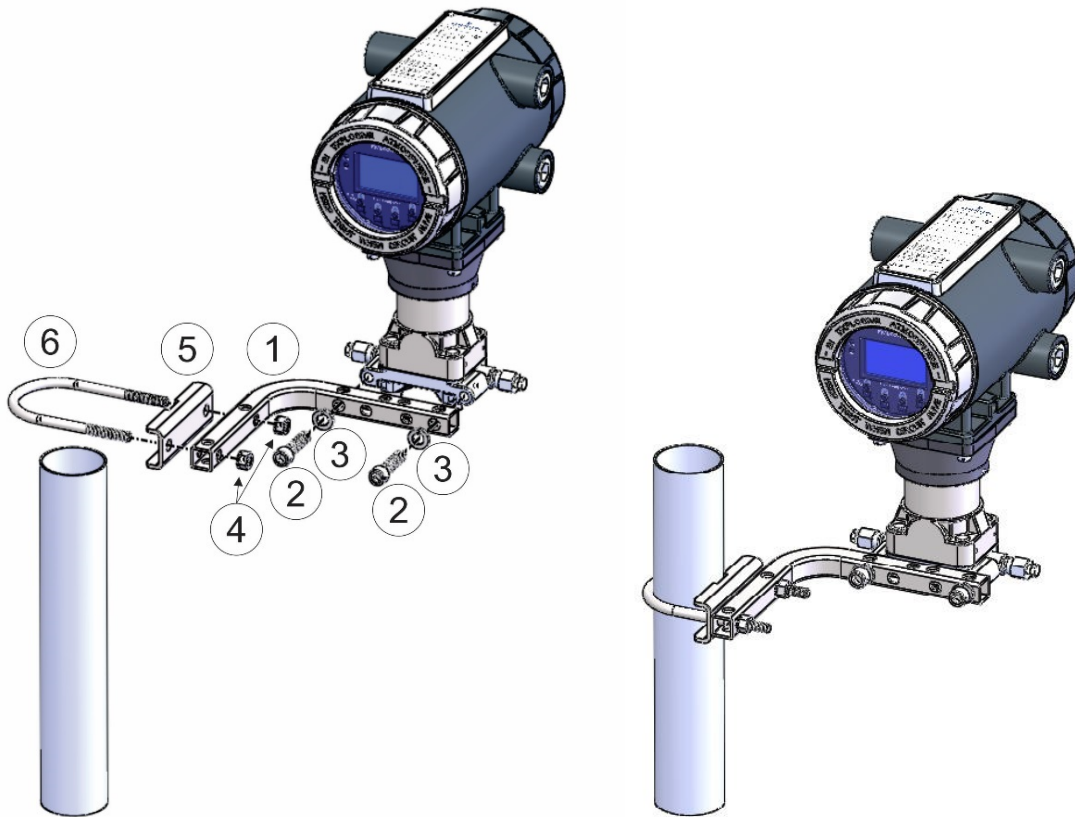

- 1 Tubular L-shaped bracket
 - 2 3/8-16 x 1 1/2 in socket head wire lockable screw (2) – Apply Killark® LUBG-6 anti-seize lubricant to threads. Torque screws to 30 in-lbs (3.4 N m)
 - 3 Split 3/8 lock washer (2)
 - 4 5/16-18 keps nut (2). Apply Loctite® 222™ Low Strength Purple Threadlocker to nuts. Torque nuts to 30 in-lbs (3.4 N m)
 - 5 U-bolt bracket
 - 6 2-inch diameter pipe U-bolt
-

Inline Mounting Kit

⚠ DANGER

EXPLOSION HAZARD: Ensure the area in which you perform this operation is non-hazardous. Performing this operation in a hazardous area could result in an explosion.

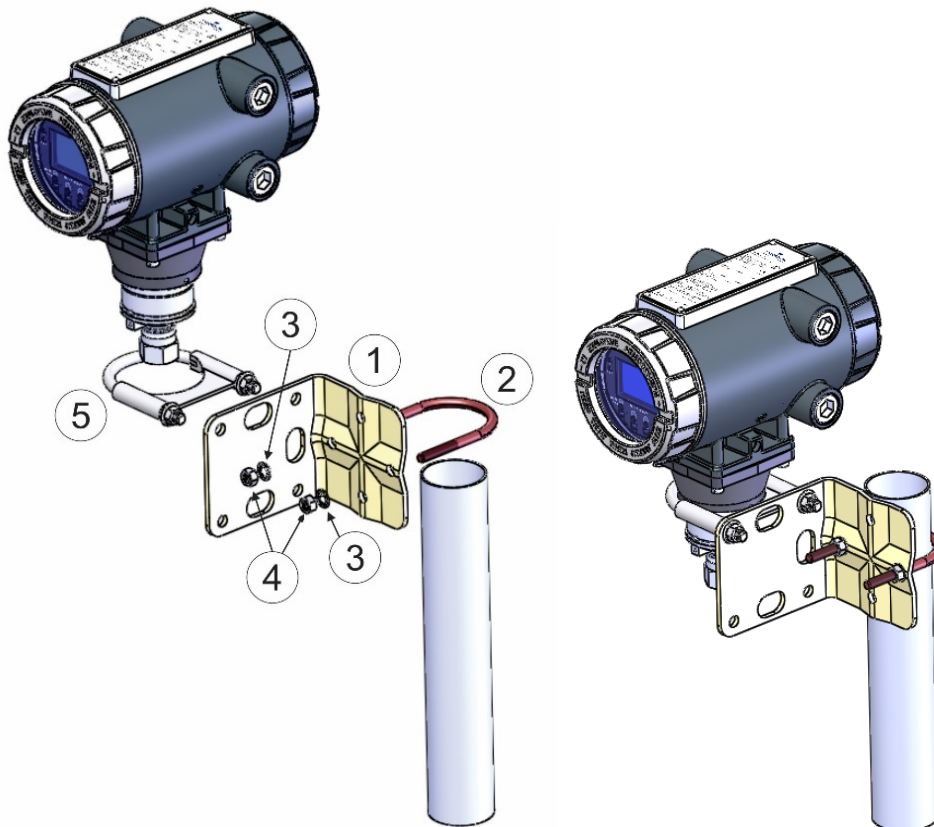

- 1 Pipe mounting bracket
- 2 U-bolt 2 ½ inch diam. pipe (5/16-18 x 3.75 long)
- 3 5/16 flat lock washer (2)
- 4 5/16-18 300 series hex nut (2) - Apply Loctite 222 Low Strength Purple Threadlocker to threads. Torque nuts to 30 in-lbs (3.4 N m)
- 5 U-bolt clamp assembly - Apply Loctite 222 threadlocker to threads. Torque nuts to 30 in-lbs (3.4 N m)

Traditional Flange Mounting Kit

⚠ DANGER

EXPLOSION HAZARD: Ensure the area in which you perform this operation is non-hazardous. Performing this operation in a hazardous area could result in an explosion.

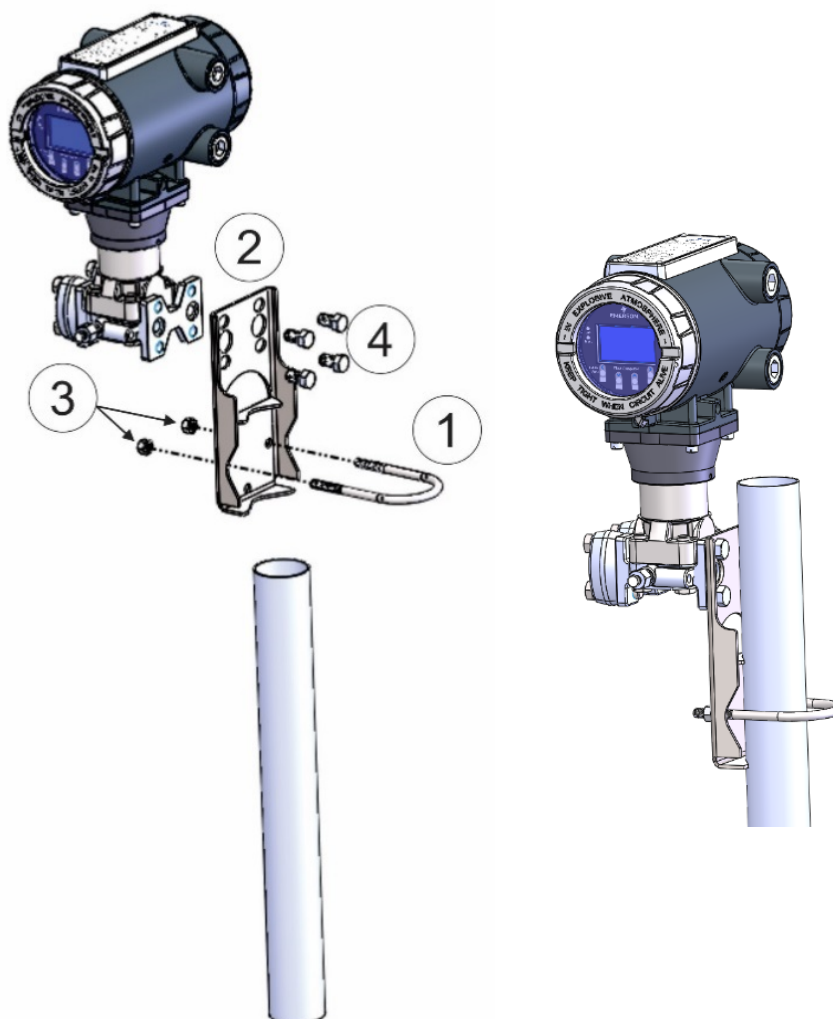

- 1 2.0 in. pipe diam. U-bolt assembly (5/16-18 x 4.0 LG) with (2) nuts (item 3)
 - 2 Mounting bracket
 - 3 Apply Loctite 222 Low Strength Purple Threadlocker to nuts. Torque nuts to 30 in-lbs (3.4 N m)
 - 4 7/16-20 x .625 cs/zinc cobalt screws (4). Torque to 30 in-lbs (3.4 N m)
-

Terminal Plate

The terminal plate includes the various terminal blocks (TB) for power and I/O connections.

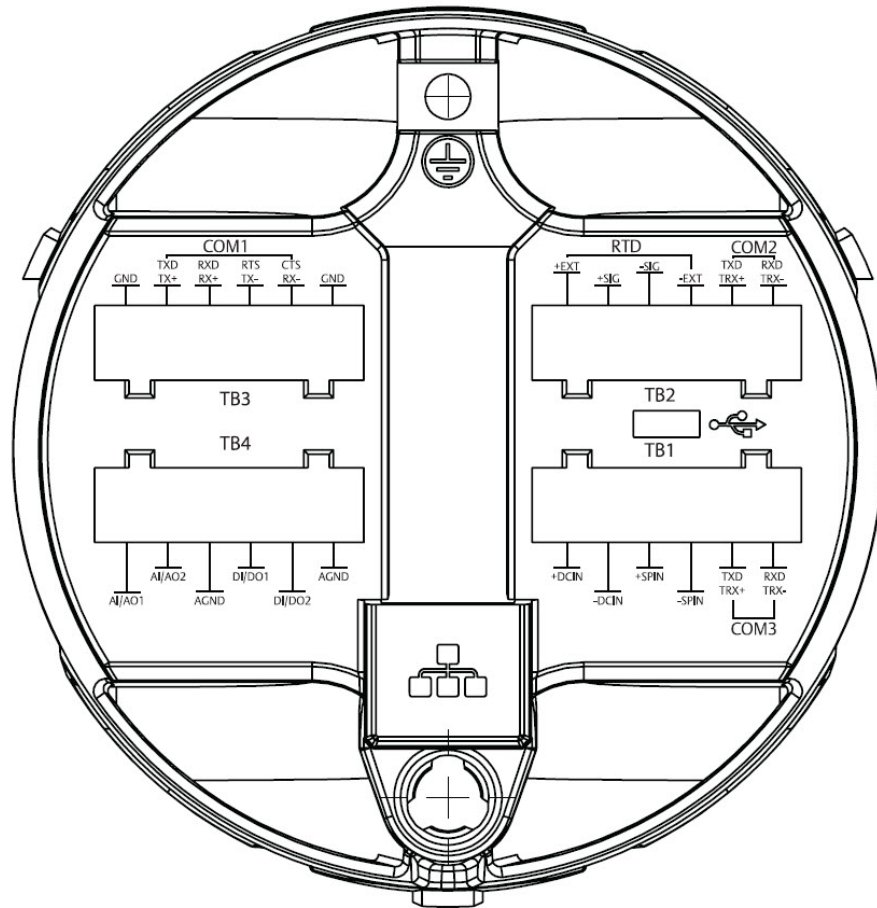

Grounding

DANGER

EXPLOSION HAZARD: Ensure the area in which you perform this operation is non-hazardous. Performing this operation in a hazardous area could result in an explosion.

The flow computer includes a ground lug on the terminal plate.

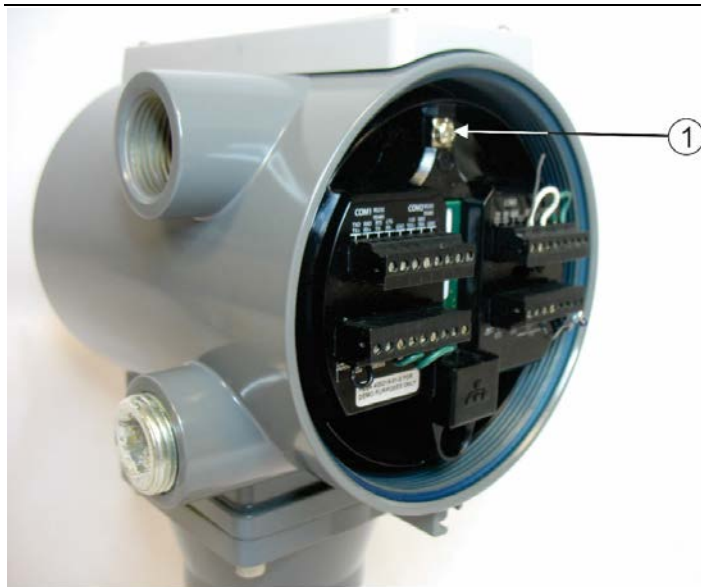

1 Ground Lug

- Once you have installed the unit, run a ground wire between the ground lug and a known good earth ground. You route the ground wire through one of the conduit fittings.
- Use stranded copper wire to earth ground, and keep the length as short as possible.
- Clamp or braze the ground wire to the ground bed conductor (typically a stranded copper AWG 0000 cable installed vertically or horizontally).
- Using a high-wattage soldering iron, tin the wire ends with solder before you insert them into the chassis ground lug.
- Run the ground wire so that any routing bend in the cable has a minimum radius of 30.48 cm (12 inches) below ground and 20.32 cm (8 inches) above ground.
- For more information on grounding or if your installation uses cathodic protection, refer to *Site Considerations for Equipment Installation, Grounding, and Wiring* (D301452X012).

Communications Wiring

Notes

- You do not need to add termination resistors; you can configure termination through software selections in FBxConnect.
- You should terminate all shields at chassis ground.

⚠ DANGER

EXPLOSION HAZARD: Ensure the area in which you perform this operation is non-hazardous. Performing this operation in a hazardous area could result in an explosion.

- COM1

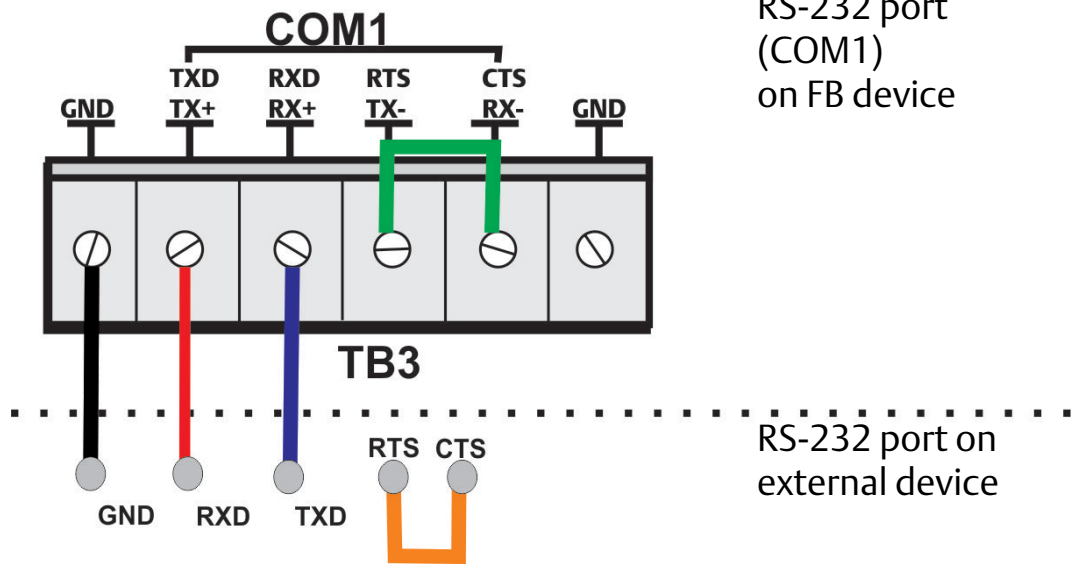

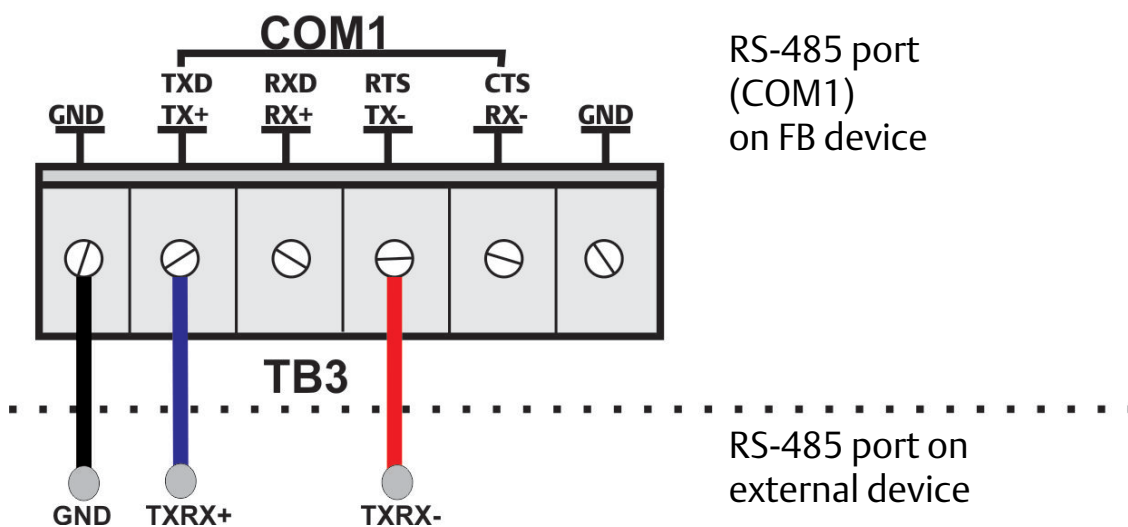
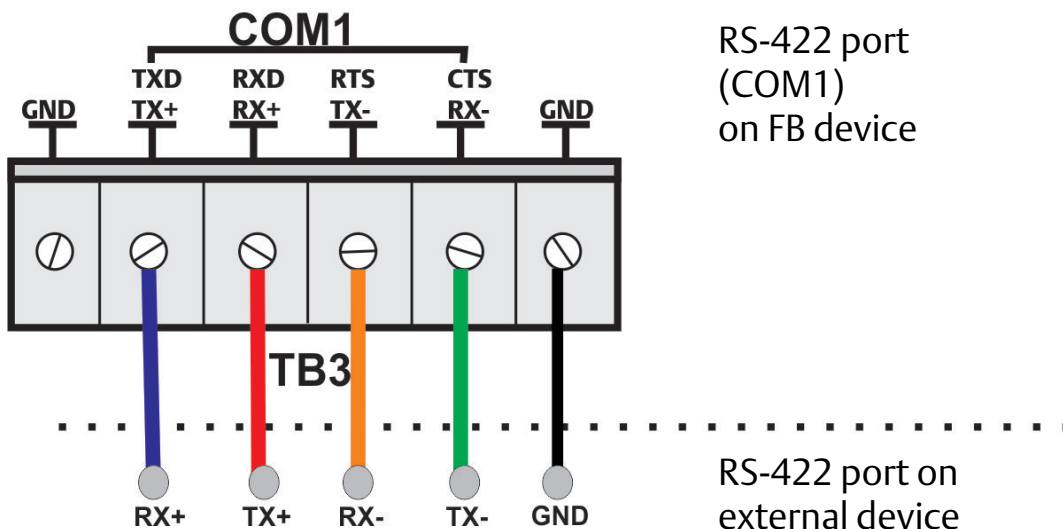

- COM2
(COM2 does not have its own GND terminal. Use either GND terminal on the COM1 terminal block.)

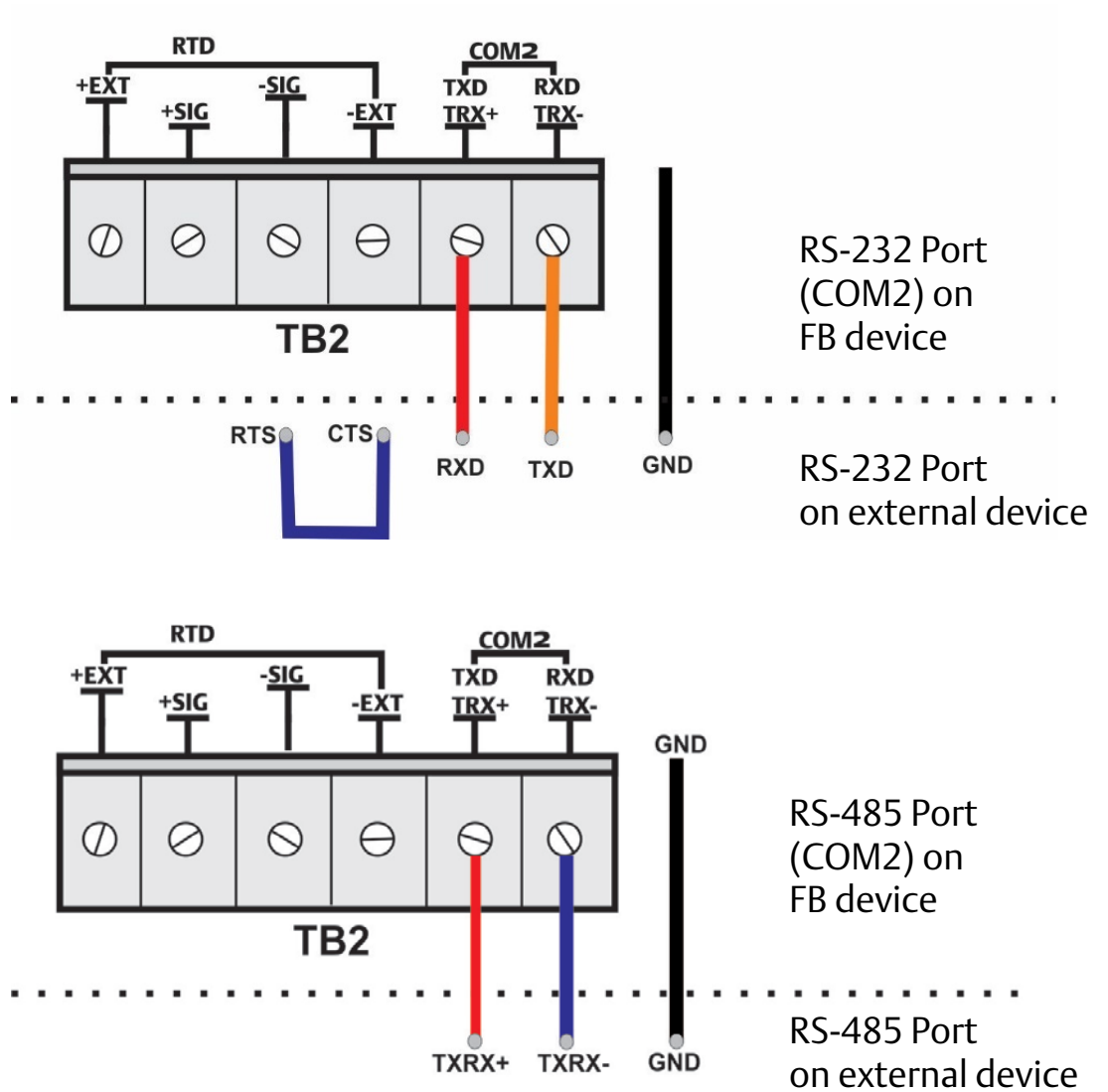

- COM3

(COM3 does not have its own GND terminal. Use either GND terminal on the COM1 terminal block.)

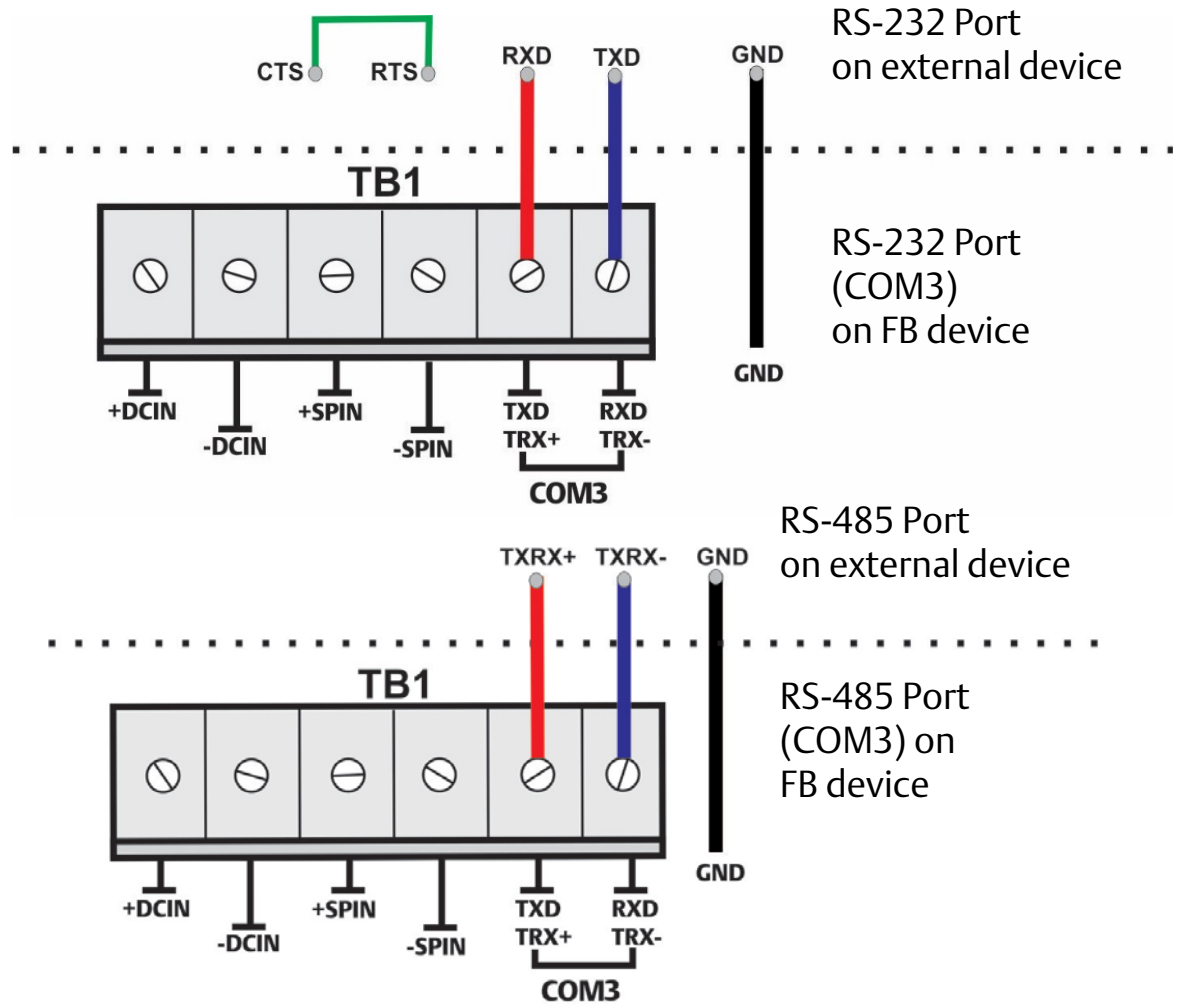

I/O Wiring

⚠ DANGER

EXPLOSION HAZARD: Ensure the area in which you perform this operation is non-hazardous. Performing this operation in a hazardous area could result in an explosion.

Note

You should terminate all shields at chassis ground.

Note

When using the digital output to drive an inductive load (such as a relay coil), place a suppression diode across the load. This protects the DO from the reverse Electro-Motive Force (EMF) spike generated when the inductive load is switched off.

- Digital Output (external powered)

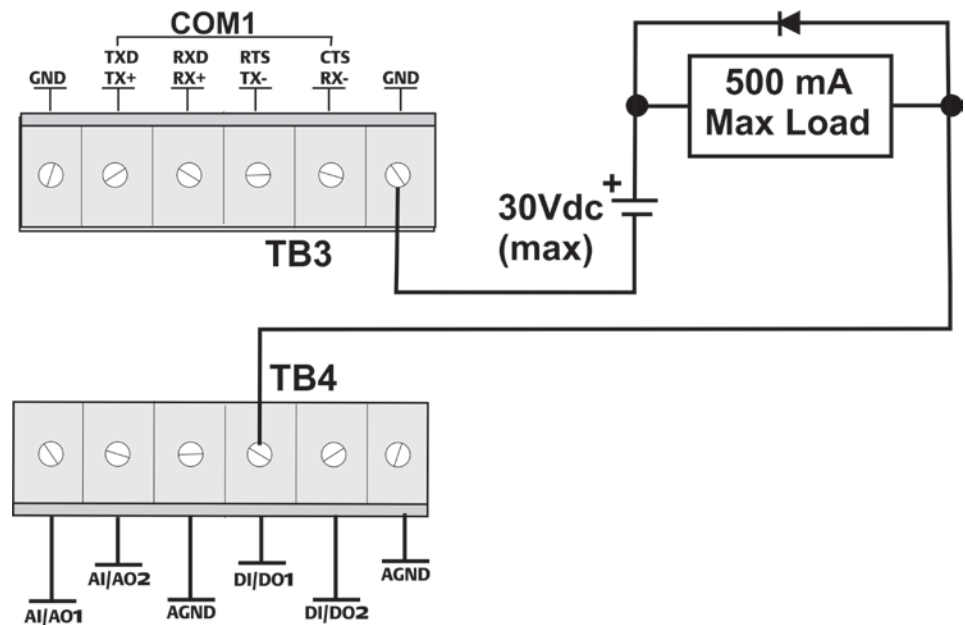

- 2-Wire RTD:

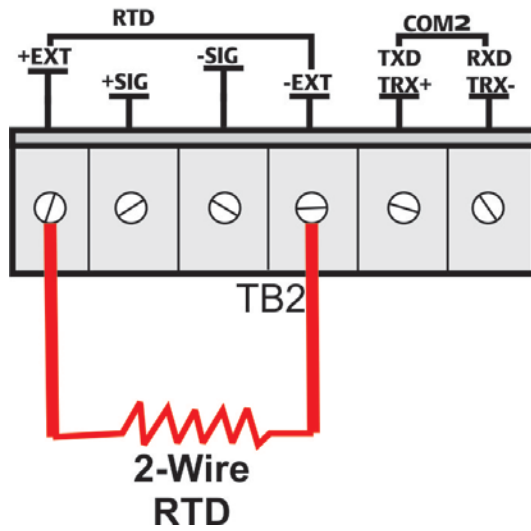

- 3-Wire RTD:

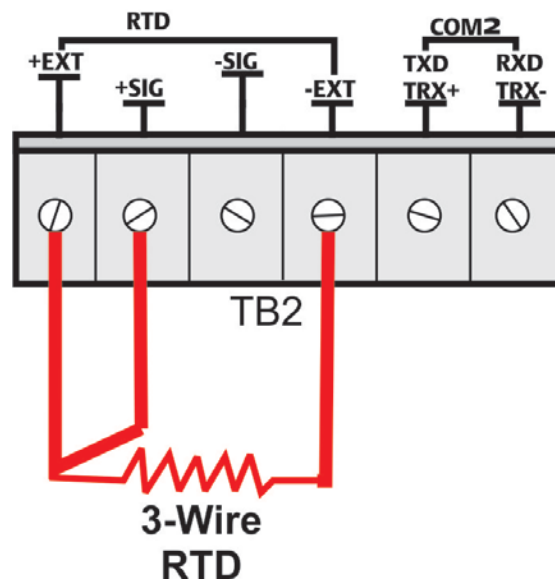

- 4-Wire RTD:

Note

The default configuration is 4-wire RTD; you can change the configuration in FBxConnect.

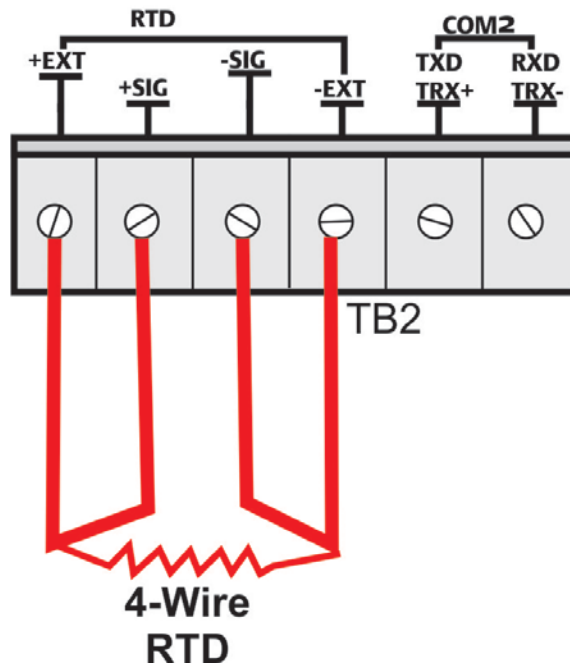

Power Wiring

⚠ DANGER

EXPLOSION HAZARD: Ensure the area in which you perform this operation is non-hazardous. Performing this operation in a hazardous area could result in an explosion.

The flow computer accepts DC power with an input voltage range from 5.7 to 30V. The amount of power required depends on installed options.

- DC Power:

To External power supply

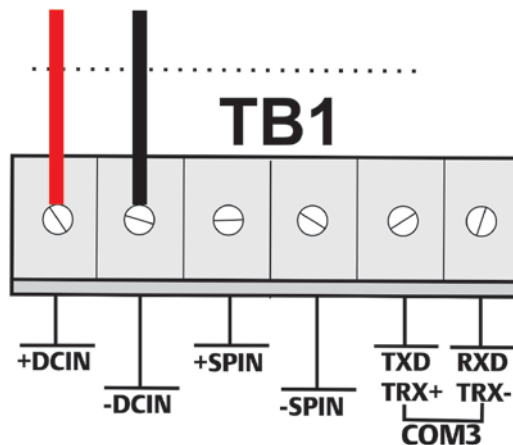

- Solar Power:

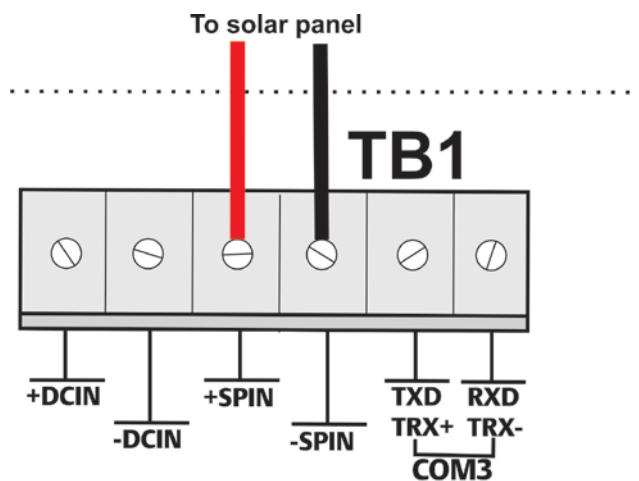

Connecting the Main Battery Pack

⚠ DANGER

EXPLOSION HAZARD: Ensure the area in which you perform this operation is non-hazardous. Performing this operation in a hazardous area could result in an explosion.

If you purchased one of the battery/solar panel options, note that the device ships with the battery pack disconnected to preserve battery life. You need to connect the main battery pack before you place the device in service.

The device provides two battery connections, enabling you to hot-swap the battery pack in a non-hazardous location.

1. Remove the front end cap by unscrewing it counter-clockwise.
2. Loosen the four captive fastening screws that hold the HMI module. Carefully pull the module away from the flow computer and off the tab and set it aside.



3. Connect the battery to either of the two connectors.

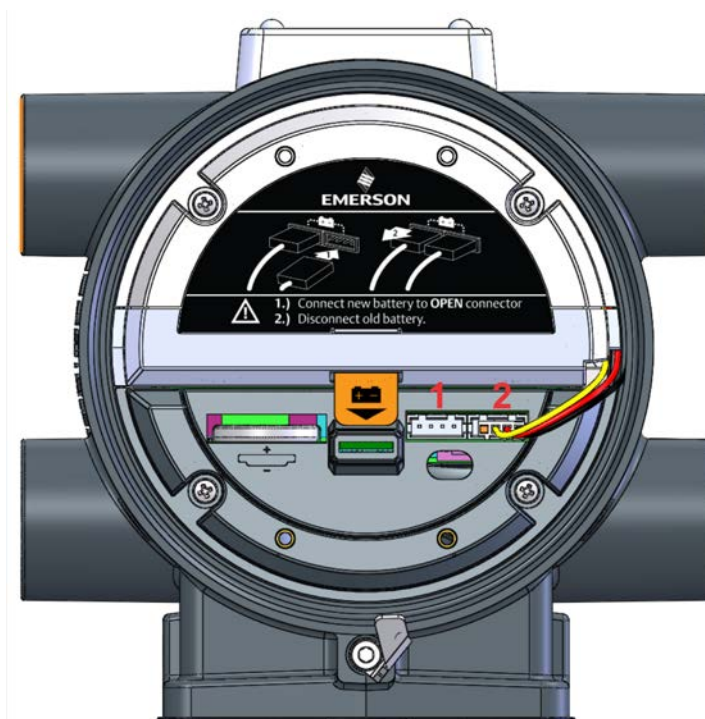

4. Carefully slide the HMI module back onto the tab and tighten the four captive fastening screws.
5. Reattach the end cap. Screw it clockwise (eight full turns) until it is tightly sealed to the enclosure.

Replacing the Main Battery Pack

Periodically you must replace the main battery pack. FBxConnect provides a battery life indicator showing the number of days of usage to help you monitor battery life. In addition, for lithium batteries only, the Status LED shows yellow when the battery is low and needs to be replaced.

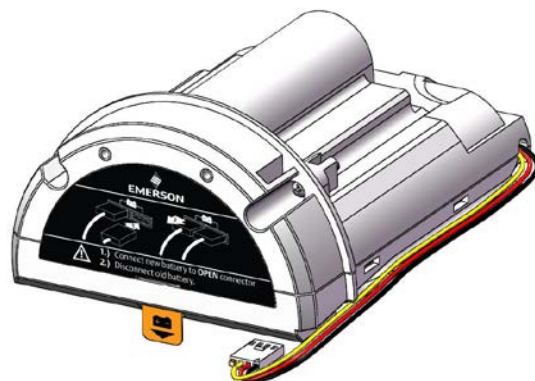

The device provides two battery connectors, enabling you to hot-swap the battery pack in a non-hazardous location. Slide out the first battery pack (leaving it connected), attach the new battery to the second (available) connector (so both batteries are connected), and then disconnect the old battery pack.

⚠ DANGER

EXPLOSION HAZARD – Do not replace batteries unless power has been switched off or the area is known to be non-hazardous. Batteries must only be changed in an area known to be non-hazardous.

⚠ WARNING!

There are no user-serviceable parts inside the battery pack. Do not open the battery pack as you may damage the battery pack or injure yourself.

Note

These cells are to be used only in devices where servicing of the cell circuit and replacement of the lithium cells will be done by a trained technician.

Keep the replacement battery pack handy during the procedure.

1. Remove the front end cap.

2. Loosen the two captive fastening screws on the battery pack.



3. Loosen the two bottom captive fastening screws on the HMI module. Leave the two top screws on the HMI module connected to the battery pack.
4. Grasp the HMI module and gently pull it and the battery pack out of the enclosure, leaving the battery still connected.



5. Connect the new battery to the open connector. Route the wires so they are in the recessed area. Make sure the wires don't get caught in the end cap threads.
6. Disconnect the old battery pack's connector from the unit and set the old battery pack aside.
7. Slide the new battery pack into the unit. Tighten its two captive fastening screws.
8. Loosen the top captive fastening screws on the HMI module to separate it from the old battery pack.
9. Align the HMI module with the new battery pack and the tab on the CPU carrier board (bezel). Gently press the HMI module on, being careful not to pinch the battery wires. Tighten all four captive screws.
10. Replace the front end cap. Screw it clockwise (eight full turns) until it is tightly sealed to the enclosure.

Powering Up/Powering Down the Device

DANGER

Do not attempt to connect power or disconnect power from the unit in a hazardous area. Ensure the area is non-hazardous. Failure to do so could result in an explosion.

1. Remove the front end cap.
2. Terminal block TB1 includes connections for DC power (+DCIN, -DCIN) and battery/solar power (+SPIN, -SPIN). Battery power (which is also used with solar power) has its own internal connection.
 - Plug in TB1 to activate DC or solar power. If your device uses an internal battery and it is not connected, connect it as discussed in *Connecting the Main Battery Pack*.
 - Unplug TB1 to deactivate DC or solar power. If your device uses an internal battery, disconnect the main battery.
3. Replace the front end cap. Screw it clockwise (eight full turns) until it is tightly sealed to the enclosure.

This turns on (or turns off) power from an external power supply or from the battery pack/solar panel.

Note

When you turn power on, the backlight on the HMI module lights, momentarily turns off and then remains lit while the INPUT LED blinks. After approximately one minute the initialization process finishes and the HMI starts to display live data.

Install Field Tools Configuration Software

You install Field Tools software (which includes FBxConnect) on your PC to configure the device.

Important

- Field Tools (including FBxConnect) is available as a free software download to registered [SupportNet](#) users. If you are not a registered SupportNet user, new accounts take up to 24 hours to process so plan accordingly.
 - AMS Device Configurator (which is part of Field Tools) is incompatible with AMS Device Manager: they cannot reside on the same machine.
 - If you have a previous version of Field Tools already installed on your PC, uninstall it and reboot your PC before you install this new version.
 - Before beginning the installation, close all other applications.
 - Field Tools cannot reside on a computer running any component of OpenEnterprise 2.x, OpenEnterprise 3.x, OpenEnterprise Client/Server, or ObjectServer software.
 - TechView and other components of BSI_Config software cannot be installed on a computer running OpenBSI Network Edition versions older than 5.9 Service Pack 2.
 - You must have administrative privileges to install Field Tools.
 - You must disable User Account Control (UAC) prior to installing Field Tools (you can re-enable it after a successful installation).
 - As part of the installation, software from both Eltima and MACTek® is automatically installed. Depending upon your permissions, Windows may require you to confirm these installations before the installation can proceed.
-
1. Right click on the installer file, and choose Run as administrator from the pop-up menu. For details on minimum hardware/software requirements as well as more details on the installation steps see the *Field Tools Quick Start Guide* (D301703X412).

Note

During Field Tools installation, you must select the FBx support including FBxConnect option.

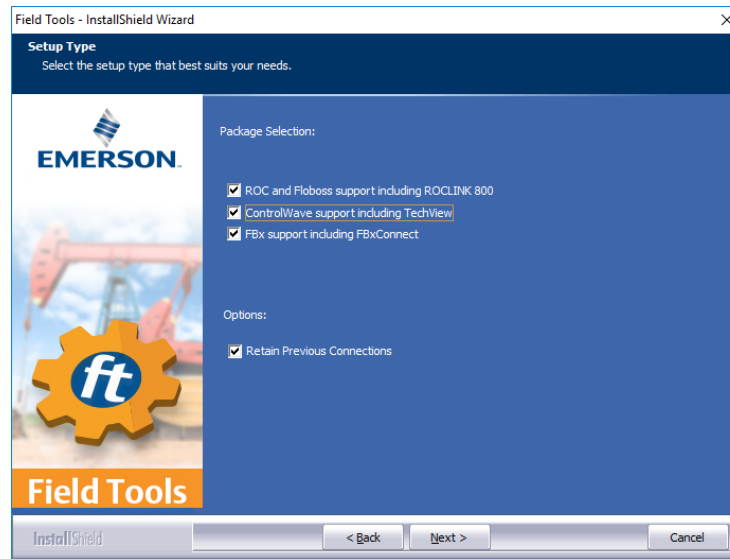

2. After software installation re-boot, start Field Tools from either the Windows Start Programs menu or (if you created it) from the desktop icon.
3. Log onto Field Tools.

Important

The very first time you login with Field Tools, use the default username of admin and leave the password field blank. Then assign a new password when prompted. See the *Field Tools Quick Start Guide* for any questions you have on changing default passwords after installation.

Establish a Connection and Launch the Setup Wizard

⚠ CAUTION

When making multiple FBxConnect connections to the same device (as with a remote and a local connection), be aware that the changes one connection makes to the device may not be immediately visible to other connections, and may even require the other connections to restart FBxConnect before changes become visible. For example, simple changes (such as changes to setpoints) may be immediately visible to all connections, but changing the number of meters, configuring I/O, adding/deleting menu items, or other major configuration changes may require re-establishing the connection using FBxConnect.

After you start Field Tools you connect to the device and launch the initial setup wizard.

- For a serial connection, connect a serial cable between either COM1 or COM2 on the device and a serial port (or USB/serial adapter) on your PC.
 - WiFi® connections are possible if you purchased the Mobile SCADA option and if your PC supports wireless communication.
1. Click Connections > Add connection.

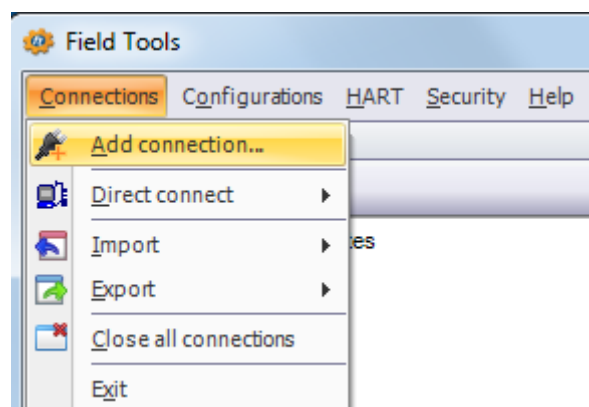

2. Choose FBx as the Device Platform.

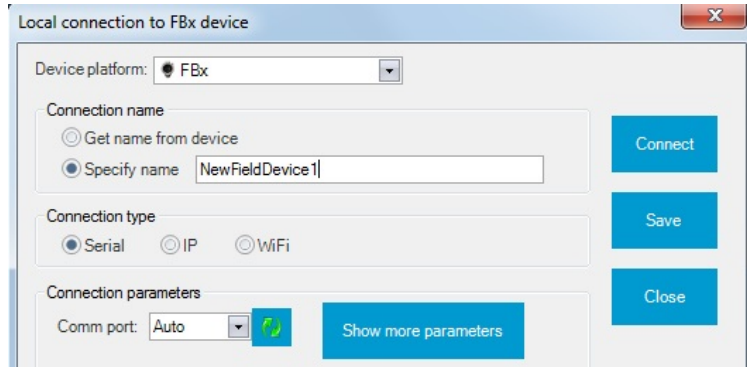

3. Choose a Connection Type

- For serial: choose the PC Comm port (or the port for the USB/serial adapter).

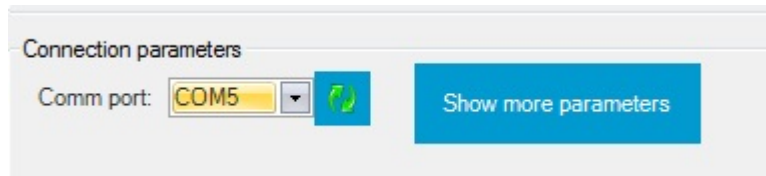

- For WiFi: choose the default WiFi Network. The format for the WiFi Network (SSID) is similar to WiFi Network:FBxxx_serialnumber. Then you must enter the default Security Key: EmersonFBXX00. The flow computer's default IP Address for WiFi is 192.168.1.10.

Important

You must change the Security Key for your network to something that is different from the default or else anyone reading this document will know your key.

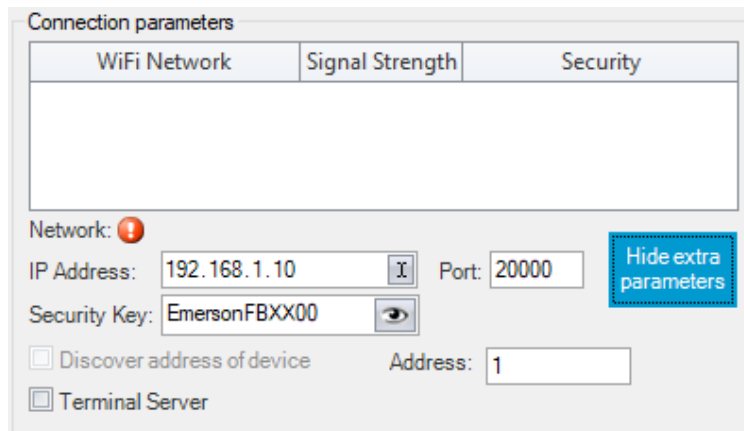

- Click Connect. Field Tools activates the connection and automatically launches the FBxConnect tool.
- When prompted, enter admin for both the Username and Password.

Important

When you finish initial configuration activities, be sure you change the password for the admin user. Otherwise, anyone reading this document could gain access to your device.

- When FBxConnect opens, click Configure.

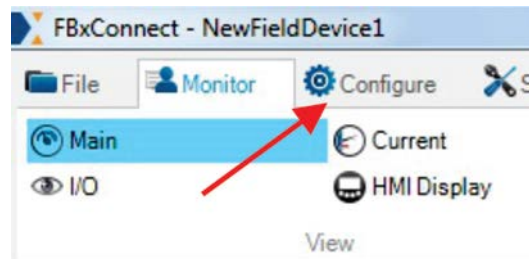

- Click Initial Setup to launch the setup wizard.



- Follow the on-screen instructions to configure the device. Click Next (or Apply) to proceed through pages of the wizard or click Previous to return to a previous page. When you are done, click Finish.

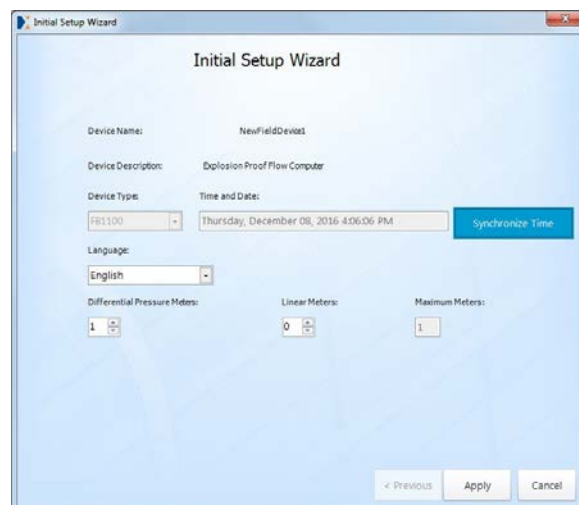

For customer service and technical support, visit www.Emerson.com/SupportNet

Global Headquarters,

North America, and Latin America:

Emerson Automation Solutions
Remote Automation Solutions
6005 Rogerdale Road
Houston, TX 77072 U.S.A.
T +1 281 879 2699 | F +1 281 988 4445
www.Emerson.com/RemoteAutomation

Europe:

Emerson Automation Solutions
Remote Automation Solutions
Unit 8, Waterfront Business Park
Dudley Road, Brierley Hill
Dudley UK DY5 1LX
T +44 1384 487200 | F +44 1384 487258

Middle East/Africa:

Emerson Automation Solutions
Remote Automation Solutions
Emerson FZE
P.O. Box 17033
Jebel Ali Free Zone – South 2
Dubai U.A.E.
T +971 4 8118100 | F +971 4 8865465

Asia-Pacific:

Emerson Automation Solutions
Remote Automation Solutions
1 Pandan Crescent
Singapore 128461
T +65 6777 8211 | F +65 6777 0947

© 2018 Remote Automation Solutions, a business unit of Emerson Automation Solutions. All rights reserved.

This publication is for informational purposes only. While every effort has been made to ensure accuracy, this publication shall not be read to include any warranty or guarantee, express or implied, including as regards the products or services described or their use or applicability. Remote Automation Solutions (RAS) reserves the right to modify or improve the designs or specifications of its products at any time without notice. All sales are governed by RAS terms and conditions which are available upon request. RAS accepts no responsibility for proper selection, use or maintenance of any product, which remains solely with the purchaser and/or end-user.