

# ControlWave® PAC Redundant Systems

Emerson's ControlWave® PAC redundant systems are designed to prevent a single point of failure from shutting down the entire system. Redundant systems are ideal for use in critical processes and harsh applications that require maximum operational readiness and system availability. Two types of redundant systems are available for the ControlWave PAC: the redundant process control and communications system and the redundant input/output (I/O) system.

Both types of redundant systems provide you with dual CPUs, dual power supplies, dual communication paths, and automatic switching between redundant components without any data loss. The redundant I/O system adds an additional layer of protection by automatically detecting problems and switching between I/O racks if any single module or point fails. Both designs deliver redundant systems that provide high availability, reliability, and safety.

## Features

- Process control redundancy and communications redundancy.
- Optional I/O redundancy.
- Dual CPUs.
- Dual power supply sequencers.
- Automatic failure detection.
- Automatic switchover to hot standby controller.
- No single point of failure.
- Communication channel switching.
- Alarm and historical data backup.
- No programming required for redundancy data transfer.



*ControlWave PAC Redundant Process Control and Communication System*

## Redundant Process Control and Communications System

The redundant process control and communications system provides you with redundant process control, multiple communication paths, and automatic failure detection including switching of the CPUs and communication paths. The redundant process control and communications system consists of an aluminium chassis that houses the primary and backup CPUs, primary and backup Power Supply Sequencer modules (PSSMs), and the CPU and Communications Redundancy Switch panel (CCRS). This chassis is then connected to ControlWave PAC I/O Expansion Racks via Ethernet.

### Dual CPUs

The redundant process control and communications system has two CPUs: a primary CPU and a backup CPU. In the event of a primary CPU failure, the system automatically switches to the backup CPU. All process control and communication functions automatically switch to the backup CPU. This method offers a high degree of control reliability and system availability at the most economical cost.

### Switch Panel

The CPU and Communications Redundancy Switch panel (CCRS) allows automatic and manual selection of the primary CPU, PSSM, and up to four serial communication ports. LEDs visually indicated the operation and status of the redundant system.

## Redundant I/O System

In addition to process control and communications redundancy, the redundant I/O system adds an additional layer of protection by automatically detecting problems and switching between I/O module racks.

The redundant I/O system consists of an aluminium chassis that houses a Redundant Power Supply Sequencer Module (RPSSM), the CPU and Communications Redundancy Switch panel (CCRS), and I/O switches connected to two identical ControlWave PACs. Analog output (AO) modules with read-back and digital output (DO) modules with read-back provide further data consistency verification.

### I/O Switches

Each I/O switch is connected to two identical I/O modules in two separate ControlWave PACs. The I/O switch receives the process I/O signals from the field. The signals from the field are passed through the I/O switch to the primary I/O

module. If a failure is detected, the I/O switch sends the signal to the backup I/O module and no data is lost.

**Switch Panel**

The CPU and Communications Redundancy Switch panel (CCRS) allows automatic and manual selection of the primary controller CPU, PSSM, I/O rack, and up to four serial communication ports. LEDs visually indicate operation and status of the redundant system.

**AO and DO Modules with Read-Back**

Analog output (AO) modules with eight outputs are available in two versions: standard AO or AO with read-back functionality. AO modules with read-back functionality monitor the values of their standby counterpart to verify consistency. If the monitored values are inconsistent, an alarm notification is set and the ControlWave PAC can be configured to prevent or allow switching to the failed backup I/O hardware.

Digital output (DO) modules with read-back functionality monitoring the values of their standby counterpart to verify consistency. Digital output (DO) modules with 16 outputs support read-back functionality. If the monitored values are inconsistent, an alarm notification is set and the ControlWave PAC can be configured to prevent or allow switching to the failed backup I/O hardware.

Standard AO and DO modules used in a redundant system do not perform this monitoring, and the potential exists to switch to a backup module with failed hardware. For critical processes, we recommend the AO and DO modules with read-back capability.

**Note:** You must use the same module type in any redundant pair. Do not install an AO/DO module with read-back functionality in the primary controller and a standard AO/DO module as its redundant counterpart in the backup controller, or vice versa.

**Redundant Power Supply Sequencer Module**

The Redundant Power Supply Sequencer module (RPSSM) provides the ControlWave with dual power supplies for operational redundancy. The RPSSM includes two independent power supplies: a primary power supply and a backup power supply. Should the primary power supply fail, operations automatically continue using the backup supply, and you can hot-swap the failed power supply with a spare unit without interrupting control operations. The RPSSM also supports hot-swapping of I/O modules. However, you cannot replace the RPSSM itself without first turning off power to the ControlWave.

When used as part of a redundant system, the failure off one of the two power supplies in a RPSSM would not force a failover to the other controller. Only the loss of both power supplies on the RPSSM would trigger a failover.

Each power supply on the RPSSM drives a solid state relay contact closed during normal operation. In a failure, this contact opens. You can optionally wire the contact to a

digital input (either externally or internally sourced) to provide indication of a power supply failure. Each power supply has a Power Good indication LED.

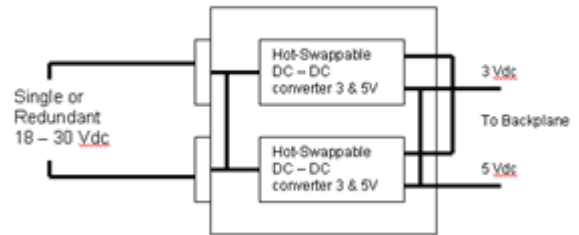

*Redundant Power Supply Sequencer Module*

**Redundant Switchover Control**

Both ControlWave PAC redundant systems use system and user-configured failure detection and switchover. System failures are automatically detected; no user programming is needed.

Possible system failures include:

- An application program running in the CPU halts due to a hardware or software fault.
- All tasks are suspended for more than a user-configurable number of milliseconds.
- A task watchdog occurs.
- Hardware failures such as memory or processor.

For even greater flexibility, you can configure (using a ControlWave Designer REDUN\_SWITCH function block) virtually any user-created logic to detect a particular failure (such as a local I/O or communication failure).

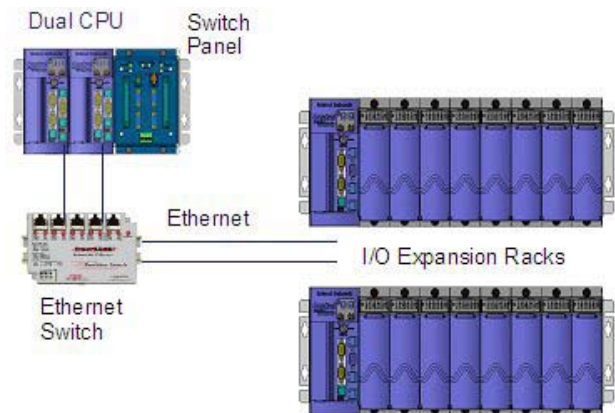

*Redundant Process Control and Communication System*

**Data Backup**

To provide a truly reliable redundant backup system with seamless transfer, both ControlWave PAC redundant systems automatically synchronize the backup CPU database from the primary CPU. Both ControlWave PAC Redundant Systems provide a backup of retained data, port, user configuration, alarm events, and the historical database. This ensures that the backup CPU has full capability to assume control without the loss of any configuration or historical database information. The backup function is pre-configured and no control programming is required.

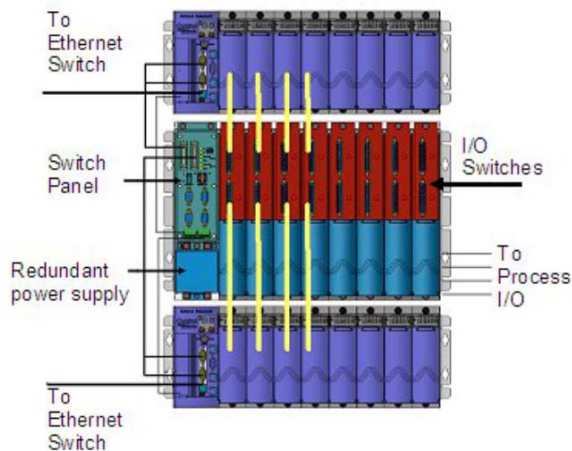

*Redundant I/O System*

## Redundant Process Control and Communication System

### System Components

Dual ControlWave PAC CPUs	Two identical Control Wave PAC CPU. Each CPU is connected to ControlWave or ControlWave Micro I/O Expansion rack CPUs via Ethernet to an Ethernet switch. For more information, refer to <i>Product Data Sheet CWPAC</i> .
CPU and Communication Redundancy Switch	A/B Primary Controller Select Switch A/B Mode Select Switch Serial Communication Port Switching On-Line Status Outputs – Contact rating 1A @ 30 Vdc LED Status indicators
Dual Power Supply Sequencer Modules (PSSM)	Two identical individual Power Supply Sequencer Modules (PSSM). Each PSSM may contain single or dual redundant power supplies. For more information, refer to <i>Product Data Sheet CWPAC</i> .
Chassis	Aluminum chassis for dual CPUs, dual PSSM, and CPU & Communication Redundancy Switch.

### Communications Redundancy Switch Panel

COM1 – COM2	Type	RS-232
	Connector	9-pin D-SUB connector
COM3 – COM4	Type	RS-485
	Connector	9-pin D-SUB connector

### Data Backup

Retained Data, Alarm Events, and Historical Data are automatically backed up.

### Physical

Dimensions	11.75 in. W by 7.1 in. H by 5 in. D (298 mm W by 180 mm H by 127 mm D)
Weight	8 lbs.
Wiring	Serial communication cables to switch included

### Environmental



Same as the ControlWave PAC. For more information, refer to *Product Data Sheet CWPAC*.

### Approvals

Same as the ControlWave PAC. For more information, refer to *Product Data Sheet CWPAC*.

## Redundant I/O System

<b>System Components</b>		
ControlWave PAC Units	The ControlWave PAC units with identical I/O setups: one primary unit and one backup unit. Each I/O module is connected to an I/O switch. For more information, refer to <i>Product Data Sheet CWPAC</i> .	
CPU and Communications Redundancy Switch Panel	A/B Primary Controller Select Switch A/B Mode Select Switch Serial Communication Port Switching On-Line Status Outputs – Contact rating 1A @ 30 Vdc LED Status indicators	
I/O Switches	Input and output switches with direct connections to the process I/O signals.	
AO Modules with Read-Back	Analog Output modules that monitor the value of the standby counterpart. For more information, refer to <i>Product Data Sheet CWPAC</i> .	
DO Modules with Read-Back	Digital Output modules that monitor the value of the standby counterpart. For more information, refer to <i>Technical Specifications CWPAC</i> .	
Redundant Power Supply Sequencer Module	Input Voltage Range	+20 to +30 Vdc (+24 Vdc nominal)
	Output Voltage	Isolated +5.2 Vdc
<b>Communications Redundancy Switch Panel</b>		
COM1 – COM2	Type	RS-232
	Connector	9-pin D-SUB connector
COM3 – COM4	Type	RS-485
	Connector	9-pin D-SUB connector
<b>I/O Switches</b>		
Digital Input	Local or remote terminations	
Digital Output	Local or remote terminations	
Analog Input	Local or remote terminations	
Analog Output	Local or remote terminations	
<b>Data Backup</b>		
Retained Data, Alarm Events, and Historical Data are automatically backed up.		
<b>Physical</b>		
Dimensions	19 in. W by 12.25 in. H by 5 in. D (483 mm W by 311 mm H by 127 mm D)	
Weight	> 10 lbs (4.5 kg); varies upon configuration	
Wiring	Up to 14 AWG at the removable terminal blocks	
<b>Environmental</b>		
Same as the ControlWave PAC. For more information, refer to <i>Product Data Sheet CWPAC</i> .		

Approvals		
Product Markings for Hazardous Locations	UL CUL	Class I, Division 2, Groups A, B, C, and D T4A
	CE	 0081
Certification Standard	UL Standards	UL 1604-1994 UL 508-2008 CSA C22.2 No. 213-M1987 CSA C22.2 No. 142-M1987
	EMC Standards	EN 55011 (Emissions) EN 61000-4-2 (Electrostatic Discharge Immunity) EN 61000-4-3 (Electromagnetic Field Immunity) EN 61000-4-4 (Electrical Fast Transients Immunity) EN 61000-4-5 (Surge Immunity) EN 61000-4-6 (Conducted Immunity)
Miscellaneous Approval	RoHS2	RoHS (2) EU Directive 2011/65/EU: This product may be considered out-of-scope when used for the intended design purpose in a Large Scale Fixed Installation (LSFI). Consult <a href="https://www.emerson.com/compliance">https://www.emerson.com/compliance</a> for up-to-date product information.
	RoHS (China)	

For customer service and technical support,  
visit [www.EmersonProcess.com/Remote/Support](http://www.EmersonProcess.com/Remote/Support).

**Global Headquarters,  
North America, and Latin America:**

Emerson Process Management  
Remote Automation Solutions  
6005 Rogerdale Road  
Houston, TX 77072 U.S.A.  
T +1 281 879 2699 | F +1 281 988 4445  
[www.EmersonProcess.com/Remote](http://www.EmersonProcess.com/Remote)

**Europe:**

Emerson Process Management  
Remote Automation Solutions  
Unit 8, Waterfront Business Park  
Dudley Road, Brierley Hill  
Dudley UK DY5 1LX  
T +44 1384 487200 | F +44 1384 487258

**Middle East/Africa:**

Emerson Process Management  
Remote Automation Solutions  
Emerson FZE  
P.O. Box 17033  
Jebel Ali Free Zone – South 2  
Dubai U.A.E.  
T +971 4 8118100 | F +971 4 8865465

**Asia-Pacific:**

Emerson Process Management  
Remote Automation Solutions  
1 Pandan Crescent  
Singapore 128461  
T +65 6777 8211 | F +65 6777 0947

© 2002–2017 Remote Automation Solutions, a business unit of Emerson Process Management. All rights reserved.

This publication is for informational purposes only. While every effort has been made to ensure accuracy, this publication shall not be read to include any warranty or guarantee, express or implied, including as regards the products or services described or their use or applicability. Remote Automation Solutions (RAS) reserves the right to modify or improve the designs or specifications of its products at any time without notice. All sales are governed by RAS terms and conditions which are available upon request. RAS accepts no responsibility for proper selection, use or maintenance of any product, which remains solely with the purchaser and/or end-user.