

Model 2085

Withdrawable stainless steel conductivity cell

Measurement made easy



Model 2085 withdrawable stainless steel conductivity cell

ABB Limited
Measurement & Analytics
Oldends Lane, Stonehouse
Gloucestershire
GL10 3TA
UK
Tel: +44 (0)1453 826 661
Fax: +44 (0)1453 829 671
Email: instrumentation@gb.abb.com

ABB Inc.
Measurement & Analytics
125 E. County Line Road
Warminster
PA 18974
USA
Tel: +1 215 674 6000
Fax: +1 215 674 7183

abb.com/measurement

We reserve the right to make technical changes or modify the contents of this document without prior notice. With regard to purchase orders, the agreed particulars shall prevail. ABB does not accept any responsibility whatsoever for potential errors or possible lack of information in this document. We reserve all rights in this document and in the subject matter and illustrations contained therein. Any reproduction, disclosure to third parties or utilization of its contents – in whole or in parts – is forbidden without prior written consent of ABB.
© ABB 2018

IM/2085 Rev.D 09.2018

For more information

Further publications for the 2085 conductivity cell are available for free download from:

www.abb.com/measurement

or by scanning this code:



Search for or click on

Data Sheet
2085 [DS/CONCEL-EN](#)
Conductivity cells

1. A listing evidencing process operation and alarm logs at time of failure.
2. Copies of operating and maintenance records relating to the alleged faulty unit.

Client Warranty

Prior to installation, the equipment referred to in this manual must be stored in a clean, dry environment, in accordance with the Company's published specification. Periodic checks must be made on the equipment's condition. In the event of a failure under warranty, the following documentation must be provided as substantiation:

United Kingdom
ABB Limited
Tel: +44 (0)1453 826661
Fax: +44 (0)1453 827856
United States of America
ABB Inc.
Tel: +1 (0) 775 883 4366
Fax: +1 (0) 775 883 4373

We provide a comprehensive after sales service via our Worldwide Service Organization. Contact one of the following offices for details of your nearest Service and Repair Centre.

Customer Support

Health and Safety
To ensure that our products are safe and without risk to health, the following points must be noted:
1. The relevant sections of these instructions must be read carefully before proceeding.
2. Warning labels on containers and packages must be observed.
3. Installation, operation, maintenance and servicing must only be carried out by suitably trained personnel and in accordance with the information given.
4. Normal safety precautions must be taken to avoid the possibility of an accident occurring when operating in conditions of high pressure and/or temperature.
5. Chemicals must be stored away from heat, protected from temperature extremes and powders kept dry. Normal safe handling procedures must be used.
6. When disposing of chemicals ensure that no two chemicals are mixed.
Safety advice concerning the use of the equipment described in this manual or any relevant hazard data sheets (where applicable) may be obtained from the Company address on the back cover, together with servicing and spares information.

Information in this manual is intended only to assist our customers in the efficient operation of our equipment. Use of this manual for any other purpose is specifically prohibited and its contents are not to be reproduced in full or part without prior approval of the Marketing Communications Department.

Although **Warning** hazards are related to personal injury, and **Caution** hazards are associated with equipment or property damage, it must be understood that operation of damaged equipment could, under certain operational conditions, result in degraded process system performance leading to personal injury or death. Therefore, comply fully with all **Warning** and **Caution** notices.

Note. Clarification of an instruction or additional information.

Caution. An instruction that draws attention to the risk of injury or death.

Information. Further reference for more detailed information or technical details.

Warning. An instruction that draws attention to the risk of damage to the product, process or surroundings.

Use of Instructions

1 PREPARATION

1.1 Checking the Code Number – Table 1.1

Basic Type No.	Mounting & Version	Cell Constant (K)	Process Connection Type	Temperature Compensation	
Code Characters	1,2	3,4,5	6	7	8
20 Electrolytic conductivity measuring cells	85/ Withdrawable (stainless steel)	3 0.05 4 1.0	0 Use with valve 2089	0 None 5 Pt100 resistance thermometer	

Table 1.1 Checking the Conductivity Cell Code Number

2 MECHANICAL INSTALLATION

2.1 Siting Requirements – Fig 2.1

Caution. Ensure the integral cable (where applicable) does not touch hot or abrasive objects when the plug is connected to the bulkhead socket.

Note. Allow sufficient clearance for easy removal of cell for cleaning – see Fig. 2.2 for overall dimensions of cells.

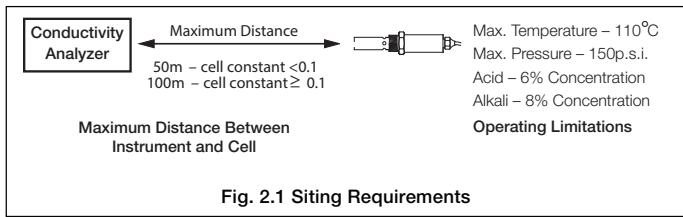

2.2 Cleaning the Conductivity Cell

Before installing the conductivity cell, clean the electrodes as follows:

Thoroughly clean the electrode bore with a nylon-bristle brush (supplied) and a warm detergent solution. For more tenacious deposits a 2% hydrochloric acid solution may be used. After cleaning, thoroughly rinse the cell with distilled water and view the bore against a bright light to ensure that the interior surfaces are evenly wetted, i.e. free from grease deposits. Avoid wetting the electrical connection terminals.

2.3 Overall Dimensions, Conductivity Cell – Fig. 2.2

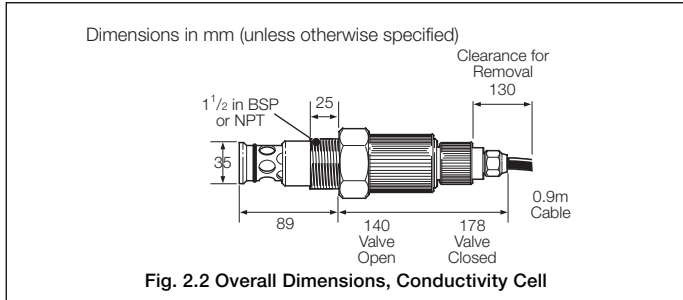

2.4 Installing the Conductivity Cell – Fig 2.3

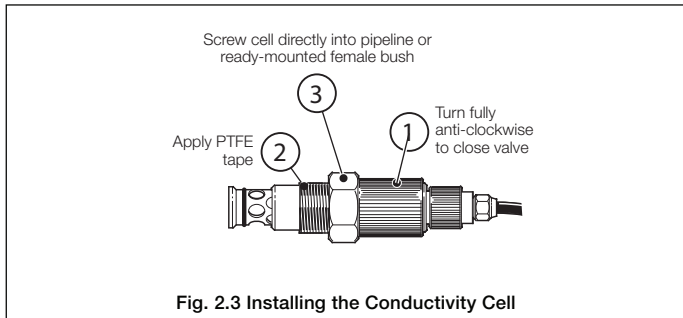

2.5 Installing the Bulkhead Socket – Fig. 2.4

Mount the socket at a convenient location close to the cell. Refer to Fig. 2.4 for overall dimensions and fixing details.

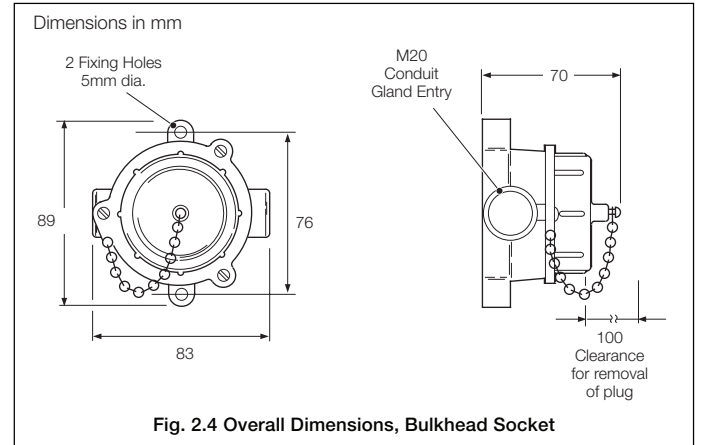

3 ELECTRICAL CONNECTIONS

Warning. Before making any connections, ensure that the power supply, any high voltage-operated control circuits and high common mode voltages are switched off

3.1 Conductivity Cell to Analyzer Connections

Information. Use cable part no. AC200/018x to connect the bulkhead socket to the analyzer.

3.1.1 Conductivity Cell Connections – Fig. 3.1

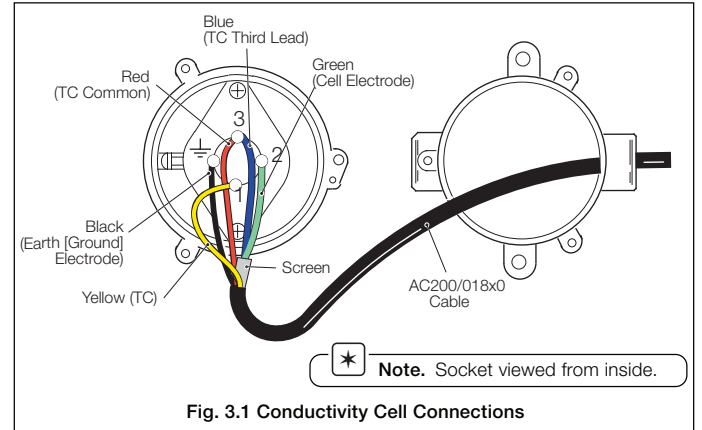

3.1.2 Analyzer Connections

Refer to the analyzer's User Guide for details of connecting cable AC200/018x to the analyzer.

3.2 Direct Cell-to-Analyzer Connection

If required, the bulkhead socket can be removed from the Model 2025 Conductivity Cell and the cell connected directly to the analyzer. Table 3.1 lists the cell cable core colors and associated cell functions – refer to the analyzer's User Guide for connection details.

Cell Cable Core Color	Cell Function
Red	TC Common
Yellow	TC
Green	Cell Electrode
Blue	Earth (Ground) Electrode

Table 3.1 Cell Cable Core Colors and Cell Functions