

STAINLESS STEEL FITTING LINE

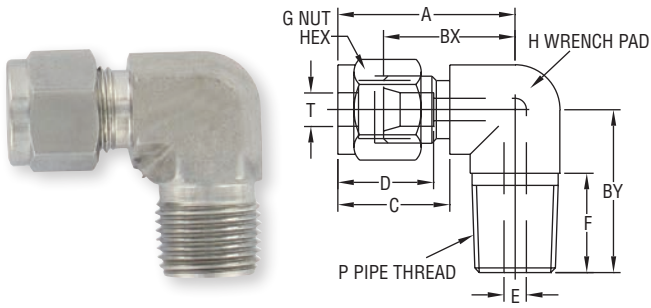

Series A-1001 Male Elbow Fitting Line

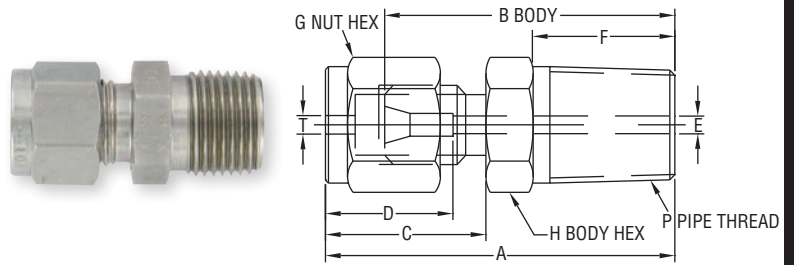

Series A-1002 Male Connector Fitting Line

MODEL CHART					
Model	T = Tube OD	P = Pipe Thread Male	Model	T = Tube OD	P = Pipe Thread Male
A-1001-1	1/16"	1/16"	A-1001-18	3/8"	1/2"
A-1001-2	1/16"	1/8"	A-1001-19	3/8"	3/4"
A-1001-3	1/8"	1/16"	A-1001-20	1/2"	1/4"
A-1001-4	1/8"	1/8"	A-1001-21	1/2"	3/8"
A-1001-5	1/8"	1/4"	A-1001-22	1/2"	1/2"
A-1001-6	3/16"	1/8"	A-1001-23	1/2"	3/4"
A-1001-7	3/16"	1/4"	A-1001-24	5/8"	3/8"
A-1001-8	1/4"	1/8"	A-1001-25	5/8"	1/2"
A-1001-9	1/4"	1/4"	A-1001-26	5/8"	3/4"
A-1001-10	1/4"	3/8"	A-1001-27	3/4"	1/2"
A-1001-11	1/4"	1/2"	A-1001-28	3/4"	3/4"
A-1001-12	5/16"	1/8"	A-1001-29	7/8"	3/4"
A-1001-13	5/16"	1/4"	A-1001-30	1"	3/4"
A-1001-15	3/8"	1/8"	A-1001-31	1"	1"
A-1001-16	3/8"	1/4"	A-1001-32	1-1/4"	1-1/4"
A-1001-17	3/8"	3/8"	A-1001-33	1-1/2"	1-1/2"

SPECIFICATIONS
Service: Liquid, steam and compatible gases.
Wetted Materials: 316 SS.
Temperature Ranges: See reference Table B. ●
Pressure Ranges: See reference Table A. ●
Connections: A-1001: 1/16" to 1-1/2"; A-1002: 1/16" to 2".
Dimensions: Consult website, or contact factory.

MODEL CHART					
Model	T = Tube OD	P = Pipe Thread Male	Model	T = Tube OD	P = Pipe Thread Male
A-1002-1	1/16"	1/16"	A-1002-24	3/8"	3/4"
A-1002-2	1/16"	1/8"	A-1002-25	1/2"	1/8"
A-1002-3	1/16"	1/4"	A-1002-26	1/2"	1/4"
A-1002-4	1/8"	1/16"	A-1002-27	1/2"	3/8"
A-1002-5	1/8"	1/8"	A-1002-28	1/2"	1/2"
A-1002-6	1/8"	1/4"	A-1002-29	1/2"	3/4"
A-1002-7	1/8"	3/8"	A-1002-30	5/8"	3/8"
A-1002-8	1/8"	1/2"	A-1002-31	5/8"	1/2"
A-1002-9	3/16"	1/8"	A-1002-32	5/8"	1/2"
A-1002-10	3/16"	1/4"	A-1002-33	5/8"	3/4"
A-1002-11	1/4"	1/16"	A-1002-34	3/4"	1/2"
A-1002-12	1/4"	1/8"	A-1002-35	3/4"	3/4"
A-1002-13	1/4"	1/4"	A-1002-36	3/4"	1"
A-1002-15	1/4"	1/2"	A-1002-37	7/8"	3/4"
A-1002-16	1/4"	3/4"	A-1002-39	1"	1/2"
A-1002-17	5/16"	1/8"	A-1002-40	1"	3/4"
A-1002-18	5/16"	1/4"	A-1002-41	1"	1"
A-1002-19	5/16"	3/8"	A-1002-42	1-1/4"	1"
A-1002-20	3/8"	1/8"	A-1002-43	1-1/4"	1-1/4"
A-1002-21	3/8"	1/4"	A-1002-44	1-1/2"	1-1/2"
A-1002-22	3/8"	3/8"	A-1002-45	2"	2"
A-1002-23	3/8"	1/2"			

● Table B: See page 432 (Introduction to Stainless Steel Fitting Line)
 ● Table A: See page 432 (Introduction to Stainless Steel Fitting Line)



STAINLESS STEEL FITTING LINE

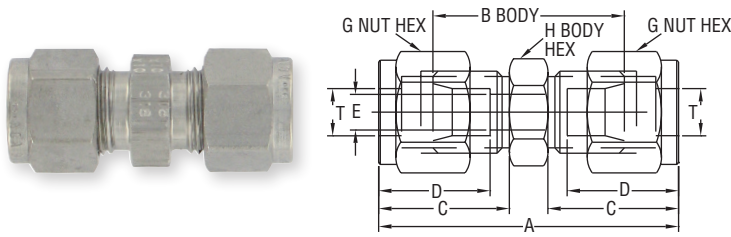

Series A-1003 Union Fitting Line

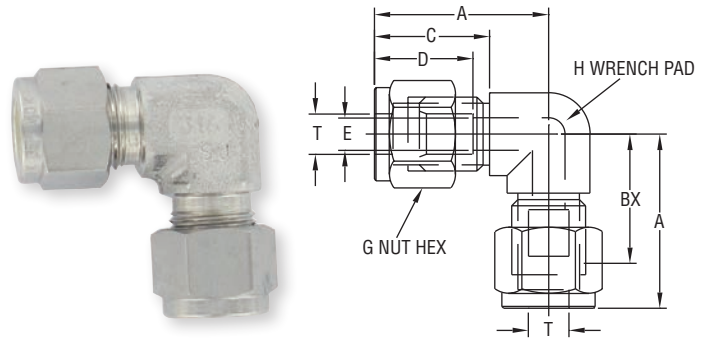

Series A-1004 Union Elbow Fitting Line

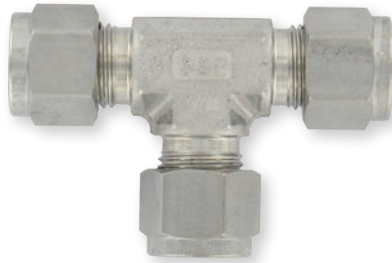

Series A-1005 Union Tee Fitting Line

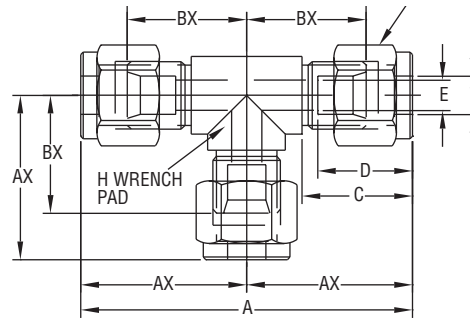

MODEL CHART			
Model	T = Tube OD	Model	T = Tube OD
A-1003-1	1/16"	A-1003-8	5/8"
A-1003-2	1/8"	A-1003-9	3/4"
A-1003-3	3/16"	A-1003-10	7/8"
A-1003-4	1/4"	A-1003-11	1"
A-1003-5	5/16"	A-1003-12	1-1/4"
A-1003-6	3/8"	A-1003-13	1-1/2"
A-1003-7	1/2"	A-1003-14	2"

SPECIFICATIONS
Service: Liquid, steam and compatible gases.
Wetted Materials: 316 SS.
Temperature Ranges: See reference Table B. ●
Pressure Ranges: See reference Table A. ●
Connections: 1/16" to 2".
Dimensions: Consult website, or contact factory.

MODEL CHART			
Model	T = Tube OD	Model	T = Tube OD
A-1004-1	1/16"	A-1004-8	5/8"
A-1004-2	1/8"	A-1004-9	3/4"
A-1004-3	3/16"	A-1004-10	7/8"
A-1004-4	1/4"	A-1004-11	1"
A-1004-5	5/16"	A-1004-12	1-1/4"
A-1004-6	3/8"	A-1004-13	1-1/2"
A-1004-7	1/2"	A-1004-14	2"

MODEL CHART			
Model	T = Tube OD	Model	T = Tube OD
A-1005-1	1/16"	A-1005-8	5/8"
A-1005-2	1/8"	A-1005-9	3/4"
A-1005-3	3/16"	A-1005-11	1"
A-1005-4	1/4"	A-1005-12	1-1/4"
A-1005-5	5/16"	A-1005-13	1-1/2"
A-1005-6	3/8"	A-1005-14	2"
A-1005-7	1/2"		

● Table B: See page 432 (Introduction to Stainless Steel Fitting Line)
 ● Table A: See page 432 (Introduction to Stainless Steel Fitting Line)

STAINLESS STEEL FITTING LINE

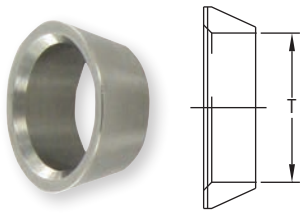

Series A-1006 Front Ferrule Fitting Line

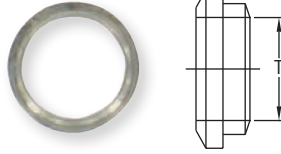

Series A-1007 Back Ferrule Fitting Line

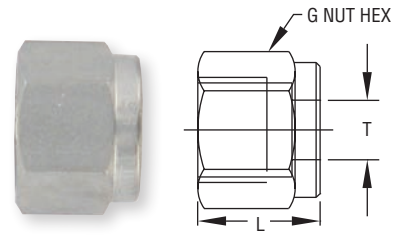

Series A-1008 Nut Fitting Line



Series A-1012 Stainless Steel Fitting Line

MODEL CHART			
Model	T = Tube OD	Model	T = Tube OD
A-1006-1	1/16"	A-1006-8	5/8"
A-1006-2	1/8"	A-1006-9	3/4"
A-1006-3	3/16"	A-1006-10	7/8"
A-1006-4	1/4"	A-1006-11	1"
A-1006-5	5/16"	A-1006-12	1-1/4"
A-1006-6	3/8"	A-1006-13	1-1/2"
A-1006-7	1/2"	A-1006-14	2"

SPECIFICATIONS
Service: Liquid, steam and compatible gases.
Wetted Materials: 316 SS.
Temperature Ranges: See reference Table B. ●
Pressure Ranges: See reference Table A. ●
Connections: A-1006, A-1007, A-1008: 1/16" to 2"; A-1012: 1/8" to 1/2".
Dimensions: A-1008, A-1012: Consult website or contact factory.

MODEL CHART			
Model	T = Tube OD	Model	T = Tube OD
A-1007-1	1/16"	A-1007-8	5/8"
A-1007-2	1/8"	A-1007-9	3/4"
A-1007-3	3/16"	A-1007-10	7/8"
A-1007-4	1/4"	A-1007-11	1"
A-1007-5	5/16"	A-1007-12	1-1/4"
A-1007-6	3/8"	A-1007-13	1-1/2"
A-1007-7	1/2"	A-1007-14	2"

MODEL CHART			
Model	T = Tube OD	Model	T = Tube OD
A-1008-1	1/16"	A-1008-8	5/8"
A-1008-2	1/8"	A-1008-9	3/4"
A-1008-3	3/16"	A-1008-10	7/8"
A-1008-4	1/4"	A-1008-11	1"
A-1008-5	5/16"	A-1008-12	1-1/4"
A-1008-6	3/8"	A-1008-13	1-1/2"
A-1008-7	1/2"	A-1008-14	2"

MODEL CHART		
Model	Hose Barb	T = Tube OD
A-1012-1	1/8"	1/8"
A-1012-2	1/8"	1/4"
A-1012-3	1/4"	1/4"
A-1012-4	1/4"	3/8"
A-1012-6	3/8"	3/8"
A-1012-9	1/2"	1/2"

● Table B: See page 432 (Introduction to Stainless Steel Fitting Line)
● Table A: See page 432 (Introduction to Stainless Steel Fitting Line)



STAINLESS STEEL FITTING LINE

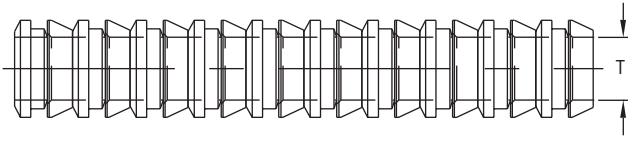

Series A-1009 Ferrule Set Fitting Line

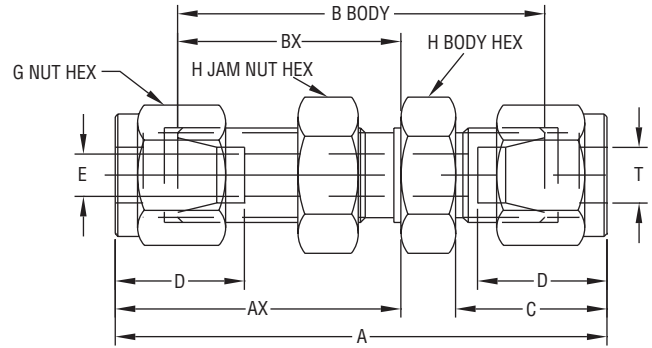
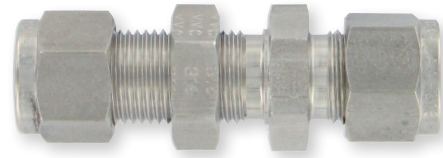

Series A-1010 Bulkhead Union Fitting Line

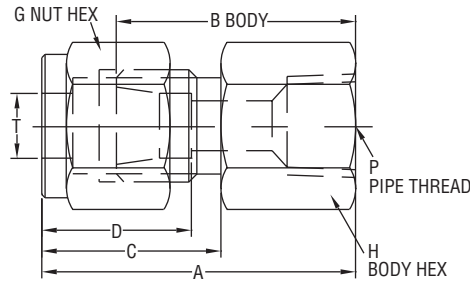
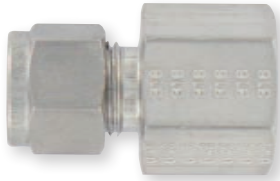

Series A-1011 Female Connector Fitting Line

MODEL CHART	
Model	T = Tube OD
A-1009-1	1/16"
A-1009-2	1/8"
A-1009-3	3/16"
A-1009-4	1/4"
A-1009-5	5/16"
A-1009-6	3/8"
A-1009-7	1/2"

MODEL CHART	
Model	T = Tube OD
A-1010-1	1/16"
A-1010-2	1/8"
A-1010-3	3/16"
A-1010-4	1/4"
A-1010-5	5/16"
A-1010-6	3/8"
A-1010-7	1/2"
A-1010-8	5/8"
A-1010-9	3/4"
A-1010-10	1"

SPECIFICATIONS
Service: Liquid, steam and compatible gases.
Wetted Materials: 316 SS.
Temperature Ranges: See reference Table B. ●
Pressure Ranges: See reference Table A. ●
Connections: A-1009: 1/16" to 2"; A-1010: 1/16" to 1"; A-1011: 1/16" to 1-1/2".
Dimensions: A-1010, A-1011: Consult website, or contact factory.

MODEL CHART								
Model	T = Tube OD	P = Pipe Thread Male	Model	T = Tube OD	P = Pipe Thread Male	Model	P = Pipe Thread Male	
A-1011-1	1/16"	1/16"	A-1011-12	3/8"	1/8"	A-1011-22	5/8"	1/2"
A-1011-2	1/16"	1/8"	A-1011-13	3/8"	1/4"	A-1011-23	3/4"	1/2"
A-1011-3	1/8"	1/8"	A-1011-14	3/8"	3/8"	A-1011-24	3/4"	3/4"
A-1011-4	1/8"	1/4"	A-1011-15	3/8"	1/2"	A-1011-25	7/8"	3/4"
A-1011-5	3/16"	1/8"	A-1011-16	3/8"	3/4"	A-1011-26	1"	3/4"
A-1011-6	1/4"	1/8"	A-1011-17	1/2"	1/4"	A-1011-27	1"	1"
A-1011-7	1/4"	1/4"	A-1011-18	1/2"	3/8"	A-1011-28	1-1/4"	1-1/4"
A-1011-8	1/4"	3/8"	A-1011-19	1/2"	1/2"	A-1011-29	1-1/2"	1-1/2"
A-1011-9	1/4"	1/2"	A-1011-20	1/2"	3/4"			
A-1011-11	5/16"	1/4"	A-1011-21	5/8"	3/8"			

Fittings, Stainless Steel

● Table B: See page 432 (Introduction to Stainless Steel Fitting Line)
 ● Table A: See page 432 (Introduction to Stainless Steel Fitting Line)