

Emerson FB2200 Flow Computer Instruction Manual



Device Safety Considerations

- **Reading these Instructions**

Before operating the device, read these instructions carefully and understand their safety implications. In some situations, improperly using this device may result in damage or injury. Keep this manual in a convenient location for future reference. Note that these instructions may not cover all details or variations in equipment or cover every possible situation regarding installation, operation, or maintenance. Should problems arise that are not covered sufficiently in the text, immediately contact Customer Support for further information.

- **Protecting Operating Processes**

A failure of this device – for whatever reason -- may leave an operating process without appropriate protection and could result in possible damage to property or injury to persons. To protect against this, you should review the need for additional backup equipment or provide alternate means of protection (such as alarm devices, output limiting, fail-safe valves, relief valves, emergency shutoffs, emergency switches, etc.). Contact Remote Automation Solutions for additional information.

- **Returning Equipment**

If you need to return any equipment to Remote Automation Solutions, it is your responsibility to ensure that the equipment has been cleaned to safe levels, as defined and/or determined by applicable federal, state and/or local law regulations or codes. You also agree to indemnify Remote Automation Solutions and hold Remote Automation Solutions harmless from any liability or damage which Remote Automation Solutions may incur or suffer due to your failure to ensure device cleanliness.

- **Grounding Equipment**

Ground metal enclosures and exposed metal parts of electrical instruments in accordance with OSHA rules and regulations as specified in *Design Safety Standards for Electrical Systems*, 29 CFR, Part 1910, Subpart S, dated: April 16, 1981 (OSHA rulings are in agreement with the National Electrical Code). You must also ground mechanical or pneumatic instruments that include electrically operated devices such as lights, switches, relays, alarms, or chart drives.

- **Protecting from Electrostatic Discharge (ESD)**

This device contains sensitive electronic components which be damaged by exposure to an ESD voltage. Depending on the magnitude and duration of the ESD, it can result in erratic operation or complete failure of the equipment. Ensure that you correctly care for and handle ESD-sensitive components.

System Training

A well-trained workforce is critical to the success of your operation. Knowing how to correctly install, configure, program, calibrate, and trouble-shoot your Emerson equipment provides your engineers and technicians with the skills and confidence to optimize your investment. Remote Automation Solutions offers a variety of ways for your personnel to acquire essential system expertise. Our full-time professional instructors can conduct classroom training at several of our corporate offices, at your site, or even at your regional Emerson office. You can also receive the same quality training via our live, interactive Emerson Virtual Classroom and save on travel costs. For our complete schedule and further information, contact the Remote Automation Solutions Training Department at 800-338-8158 or email us at education@emerson.com.

Contents

Section 1: Introduction	1
1.1 Safety Labels.....	2
1.2 Features	3
1.3 FB2200 Flow Computer Models	4
1.3.1 FB2200 Flow Computer – With Sensor	4
1.3.2 FB2200 Flow Computer – No Integral Sensor	5
1.4 Central Processing Unit (CPU)	5
1.4.1 Memory	5
1.5 Inputs & Outputs (I/O)	5
1.6 Power Options	6
1.7 Communications	7
1.8 Human-Machine Interface (HMI) Module	7
1.9 Mobile SCADA	8
1.10 Software Tools.....	9
1.11 RoHS2 Compliance	9
1.12 Physical Security	9
Section 2: Installation	13
2.1 Hazardous Locations.....	13
2.2 Environmental Specifications	13
2.3 Required Tools.....	14
2.4 Site Considerations	15
2.5 General Wiring Guidelines	20
2.6 Grounding	21
2.7 Opening/Closing the Enclosure	21
2.8 Mounting the Enclosure	22
2.8.1 Bolting Considerations	22
2.8.2 O-rings with Flange Adapters	25
2.8.3 Pole Mounting – Aluminum Enclosure	26
2.8.4 Pole Mounting – Fiberglass Enclosure	27
2.8.5 Panel/Wall Mounting Dimensions – Aluminum Enclosure	28
2.8.6 Panel/Wall Mounting Dimensions – Fiberglass Enclosure	29
2.8.7 Rotating the Housing	30
2.9 Power Modes	31
2.9.1 Low Power Mode	31
2.9.2 Standard Power Mode.....	32

2.9.3	Notes on Battery Life	33
2.10	Connecting Power	34
2.10.1	Connecting DC Power.....	34
2.10.2	Connecting Battery Power.....	36
2.10.3	Connecting Solar Power	45
	Wiring the 30W Solar Panel	45
2.11	Installing the Optional 30W Solar Panel.....	50
2.12	Adjusting the Optional Solar Panel	53
2.13	Connecting Communication Ports	55
2.13.1	Connecting to COM1	55
2.13.2	Connecting to COM2 and COM3	58
2.13.3	Ethernet Port	60
2.14	Security Intrusion Switch (OPTIONAL).....	62

Section 3: I/O Configuration and Wiring 63

3.1	Analog Inputs	65
3.1.1	AI Wiring.....	66
3.2	Analog Outputs	67
3.2.1	AO Wiring	68
3.3	Digital Inputs	69
3.3.1	DI Wiring	70
3.4	Digital Outputs	71
3.4.1	DO Wiring.....	72
3.5	Pulse Inputs	73
3.5.1	PI Wiring.....	74
3.6	Connecting the RTD/PRT	75
3.7	Connecting a Rosemount 4088B Transmitter For Use in a Second Meter Run	77
3.8	Wiring a Digital Output to the Optional Relay.....	79
3.9	Radio Wiring.....	80

Section 4: Operation..... 81

4.1	Powering Up/Powering Down the Device.....	81
4.2	Establishing Communications.....	81
4.2.1	Communicating with the SCADA Host	81
4.2.2	Communicating with a Laptop Using One of the Serial Ports	82
4.2.3	Communicating with a Laptop Using Ethernet.....	82
4.2.4	Communicating with a Laptop Wirelessly with Mobile SCADA	83
4.3	Communicating Using the HMI Module	84

Section 5: Service and Troubleshooting	87
5.1 Returning the Unit for Repairs	88
5.2 Interpreting the Status LEDs	89
5.3 Switch and Buttons	91
5.4 Removing/Replacing the HMI Module	92
5.5 Replacing the Main Battery Pack	93
5.6 Removing/Replacing the SRAM Battery.....	102
5.7 Upgrading System Firmware.....	104
Appendix A: Special Instructions for Class I Division 2 Locations..	107
Appendix B: ATEX Non-Sparking Zone 2 Certifications	111
Index	113

Section 1: Introduction

This section covers the following topics:

- Safety Labels
- Features
- FB2200 Flow Computer Models
- Central Processing Unit (CPU)
- Inputs & Outputs (I/O)
- Power Options
- Communications
- Human-Machine Interface (HMI) Module
- Mobile SCADA
- Software Tools
- RoHS2 Compliance
- Physical Security

The Emerson FB2200 Flow Computer measures pressure, differential pressure, and temperature for one or two meter runs of natural gas. It works with both differential pressure-based meters measuring static pressure (SP), differential pressure (DP), and temperature (T), and linear meters measuring pulse or analog inputs, SP, and T.

This manual describes how to install and configure the Emerson FB2200 flow computer hardware.

For information on using the FBxConnect configuration software, see the online help that accompanies FBxConnect.

Figure 1-1: FB2200 Flow Computer



- 1 HMI module
 - 2 Front cover
 - 3 Data plate
 - 4 Enclosure
 - 5 Conduit fittings
 - 6 Sensor module
-

1.1 Safety Labels



This product may display safety label(s) to identify potential hazards. The same types of notices appear within the documentation. Whenever you see an exclamation point (!) enclosed within a triangle (shown to the left), consult the documentation for additional safety information about the hazard and how to avoid it. The symbols used are:

DANGER

MAY CAUSE DEATH

Observe all precautionary signs posted on the equipment.

Failure to do so may result in death or serious injury to personnel.

WARNING

DANGER TO PERSONNEL AND EQUIPMENT

Observe all precautionary signs posted on the equipment.

Failure to do so may result in injury to personnel or cause damage to the equipment.

CAUTION

MAY CAUSE INJURY TO PERSONNEL OR DAMAGE EQUIPMENT

Observe all precautionary signs posted on the equipment.

Failure to do so may result in injury to personnel or cause damage to the equipment.

SAFETY FIRST

General instructions and safety reminders.

1.2 Features

The FB2200 flow computer includes the following key features:

- Enclosure suitable for use in Class I Division 2 non-incendive and Ex nA Zone 2 non-sparking environments. Enclosure available in either aluminum or compression-molded fiberglass.
- Optional Integral multi-variable sensor for measurement of Pressure (P) and Differential Pressure (DP)
- Optional static pressure sensor, typically used with linear meters
- Connections for customer-supplied resistance temperature detector (RTD) for measurement of temperature (T)
- Support for a second meter run through communication with a separate external transmitter
- Base I/O consists of two on-board channels you can individually configure as either digital input (DI), digital output (DO) or pulse input (PI) and two on-board I/O channels you can individually configure as either analog input (AI) or analog output (AO). Optional expansion I/O boards available.
- Power from a DC power supply or an optional lead acid battery/solar panel combination

- Serial communication options for RS-232, RS-422, and RS-485
- Optional 10/100 Base-T Ethernet port
- HMI module with optional display and back light for local operator interaction
- Optional Wi-Fi® transceiver (802.11 b/g) for field technician to access the flow computer from a laptop without physical cable connection
- Application software supports AGA3, AGA8, ISO 5167, ISO 6976, and API 21.1 calculations in either U.S., metric, or other natural gas standard units

1.3 FB2200 Flow Computer Models

You can purchase two basic models of the FB2200 flow computer.

In addition, each model is available in either an aluminum enclosure or a compression-molded fiberglass enclosure.

Either model includes two ¾ in NPT pipe-threaded conduit ports on the bottom of the enclosure to permit entry of field conduit for I/O and communication wiring.

1.3.1 FB2200 Flow Computer – With Sensor

This version includes either a multi-variable (MV) sensor module (*Figure 1-2*) or a static pressure sensor module (not shown).

Figure 1-2: FB2200 Flow Computer – Multivariable Sensor Version



1.3.2 FB2200 Flow Computer – No Integral Sensor

The no integral sensor version includes no sensor module. In this case the process variable data used in flow computer calculations comes from external devices and enters the device through the serial ports or I/O channels.

Figure 1-3: FB2200 Flow Computer – No Integral Sensor Version



1.4 Central Processing Unit (CPU)

The flow computer's CPU is a NXP® Kinetis® K61 series CPU with an ARM® Cortex® M4 processor that operates at 4 to 60 MHz depending on the power mode. The CPU runs the Micrium operating system.

1.4.1 Memory

The flow computer includes both static and flash memory.

Table 1-1: Memory

Memory	Usage
8 MB SRAM	Holds current states of all variables and historical archives
128 MB FLASH	Holds firmware image and configuration files

1.5 Inputs & Outputs (I/O)

The flow computer comes with base I/O from both the CPU and the built-in multi-variable (MV) sensor.

Base I/O consists of:

- Pressure (P) input from the MV sensor, differential pressure (DP) input from the MV sensor, connections for temperature (T) input from a customer-supplied RTD/PRT or a single static pressure sensor with RTD/PRT connections. Alternatively, you can purchase the flow computer without an integral sensor.
- Two on-board I/O channels that you can individually configure as either digital input (DI), digital output (DO), or pulse input (PI)
- Two on-board I/O channels that you can individually configure as either analog input (AI) or analog output (AO)

An optional 8-channel expansion I/O board includes:

- Four I/O channels that you can individually configure as either digital inputs (DI), digital outputs (DO), or pulse inputs (PI)
- Four I/O channels that you can individually configure as either analog inputs (AI), or analog outputs (AO)

If the optional 8-channel expansion I/O board is present, the device can optionally support an additional 6-channel expansion I/O board which includes:

- Four I/O channels that you can individually configure as either digital inputs (DI), digital outputs (DO), or pulse inputs (PI)
- Two I/O channels that you can individually configure as either analog inputs (AI), or analog outputs (AO)

Table 1-2: FB2200 I/O Configurations

FB2200 Base Unit	FB2200 purchased with 8-channel expansion I/O board	FB2200 purchased with 8-channel expansion I/O board and 6-channel expansion I/O board
<ul style="list-style-type: none"> • MV Sensor (P, DP) or Static Pressure (SP) Sensor • Connection for customer-supplied 2, 3, or 4-wire RTD/PRT 	<ul style="list-style-type: none"> • MV Sensor (P, DP) or Static Pressure (SP) Sensor • Connection for customer-supplied 2, 3, or 4-wire RTD/PRT 	<ul style="list-style-type: none"> • MV Sensor (P, DP) or Static Pressure (SP) Sensor • Connection for customer-supplied 2, 3, or 4-wire RTD/PRT
2 DI/DO/PI channels	6 DI/DO/PI channels (4 of these reside on the 8-channel expansion I/O board)	10 DI/DO/PI channels (4 of these reside on the 8-channel expansion I/O board, 4 of these reside on the 6-channel expansion I/O board)
2 AI/AO channels	6 AI/AO channels (4 of these reside on the 8-channel expansion I/O board)	8 AI/AO channels (4 of these reside on the 8-channel expansion I/O board, 2 of these reside on the 6-channel expansion I/O board)

1.6 Power Options

You can power the flow computer using an external DC input, or an internal rechargeable battery connected to a solar panel.

Important

Only use batteries supplied with the flow computer or sold by Emerson Remote Automation Solutions as spare parts for this flow computer. If you substitute a battery you obtain elsewhere **you will void your certification unless it is the identical part from the same manufacturer** as that supplied with the flow computer from Emerson.

Table 1-3: Power Options

Option	Usage
External DC Power Supply	10.5 Vdc to 30 Vdc external supply (Max power at 10 watts)
Lead Acid Battery Pack	<ul style="list-style-type: none"> • 12V • 10.5 Ah • Not suitable with ATEX or IECEx applications • Can be charged by a solar panel

1.7 Communications

The flow computer includes three serial communication ports and one Ethernet port.

The Ethernet port is an RJ-45 connector. A maximum of six concurrent TCP connections (sockets) are supported through the Ethernet port.

The serial ports allow communication using DNP3, Modbus, BSAP, and ROC protocols.

Table 1-4: Serial Ports

Port	Type	Use
COM1	<ul style="list-style-type: none"> • Serial communications • Software-selectable for RS-232, RS-422, or RS-485 operation • 4-wire 	RS-232, RS-422, or RS-485 communication to host or other devices. 4-wire used with external radio.
COM2	<ul style="list-style-type: none"> • Serial communications • Software-selectable for RS-232 or RS-485 operation • 2-wire 	RS-232 or RS-485 communication to host or other devices.
COM3	<ul style="list-style-type: none"> • Serial communications • Software-selectable for RS-232 or RS-485 operation • 2-wire 	RS-232 or RS-485 communication to host or other devices.

1.8 Human-Machine Interface (HMI) Module

The flow computer includes an HMI module with an optional liquid crystal display (LCD) for local operator access to the device. The LCD, if present, presents a series of menus that sequentially display the current values of particular process variables. A configuration parameter in FBxConnect

determines whether you must log in first to view the menus. If required, you log in by selecting alphanumeric characters by scrolling through a list until you select the correct character.

The HMI module includes four LEDs to provide status information. Units with the display include four infrared (IR) buttons for operator interaction.

To conserve power, the HMI module enters sleep mode after a period of inactivity. Sleep mode disables Wi-Fi communication. In FBxConnect, you can configure the number of minutes of inactivity triggering sleep mode through the LCD Sleep Time parameter. Setting this parameter to 0 disables sleep mode which keeps the HMI module on but uses significantly more power.

The operator wakes up the device by holding a finger against the front cover glass over the Hold to Wake button (the left-most button) for typically from five to ten seconds. You can also pre-define a number of automatic wake up times during the day from the Power Control screen in FBxConnect.

Figure 1-4: HMI Module with LCD



Figure 1-5: HMI Module without LCD



Note

If your flow computer does not include the LCD option (shown in [Figure 1-4](#)), you still have the status LEDs and a single IR button for waking up the device (shown in [Figure 1-5](#)).

1.9 Mobile SCADA

The flow computer has an optional Wi-Fi® transceiver that enables you to connect via a laptop or tablet from some small distance away. The distance supported varies depending on the

laptop/tablet type and environmental conditions, but will typically be 70 to 100 feet from the front and 40 to 60 feet from the side and rear.

This capability allows an operator to potentially remain outside the hazardous location and still communicate with the flow computer. The operator's laptop must have Wi-Fi® capability, line-of-sight access to the HMI module, and must be loaded with FBxConnect configuration software. Once connected, the operator can view process values, edit configuration parameters, and collect logs.

Note

The Mobile SCADA electronics reside inside the HMI module. The HMI module must be awake to use Mobile SCADA. You wake it up manually or you can pre-define a number of automatic wake up times during the day in FBxConnect's Power Control screen.

1.10 Software Tools

The FBxConnect configuration software provides a series of wizards that allow you to perform configuration activities for the flow computer. You connect a PC running the FBxConnect configuration software to the flow computer using one of the communication ports or through a wireless connection. You can then:

- Set parameters within your application
- Configure I/O channels
- Specify the serial communication method for a port (RS-232 to RS-485) as needed
- View or collect audit trail information such as alarm, event, or historical logs
- Update system firmware

1.11 RoHS2 Compliance

Device without Integral MVS or SP Sensor:

RoHS (2) EU Directive 2011/65/EU

Device with Integral MVS or SP Sensor:

RoHS (2) EU Directive 2011/65/EU: This product may be considered out-of-scope when used for the intended design purpose in a Large Scale Fixed Installation (LSFI).

Consult <https://www.emerson.com/compliance> for up-to-date product information.

1.12 Physical Security

The flow computer enclosure includes provision for you to padlock the door shut. The fiberglass enclosure supports two padlocks (left in *Figure 1-6*); the aluminum enclosure supports one padlock (right in *Figure 1-6*).

Figure 1-6: Locations Where Customer-Supplied Padlocks Can Be Used

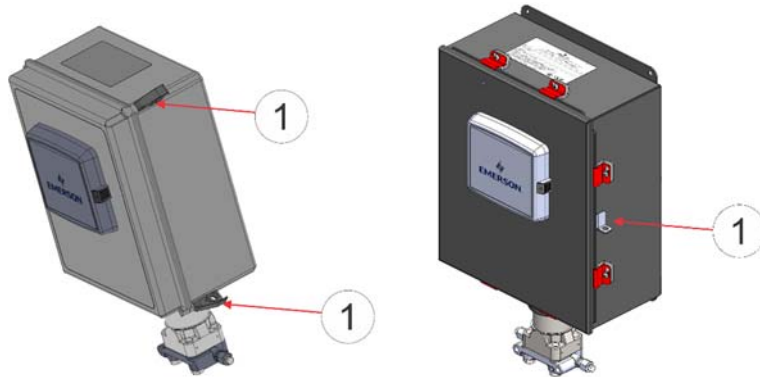

- 1 Location where customer-supplied padlocks can be used to lock the door

Holes in the door latches of the fiberglass enclosure allow you to attach a wire seal.

Alternatively, you can use a pan head screw (#10-32 X 0.81 316 SS or Monel alloy 400) with an O-ring (0.15 ID, 0.07 W) in place of one or both door latches to screw the door shut. In this case, you pry off the latch with a flat head screwdriver and pop out the mating cap to free up the holes for the screw.

Figure 1-7: Removing cap and latch from Fiberglass Enclosure

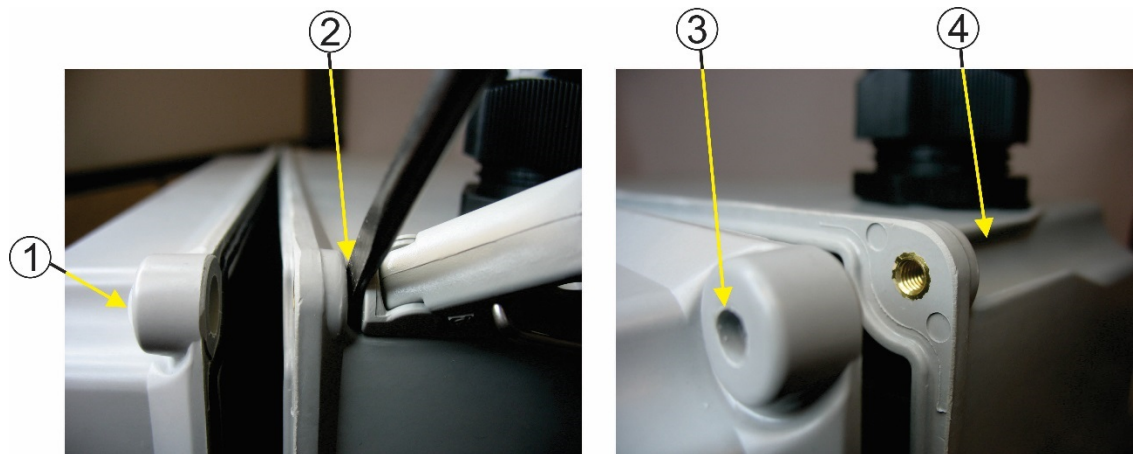

- 1 Cap
- 2 Prying off the latch
- 3 Cap removed
- 4 Latch removed

For ATEX/IEC-compliant installations with the fiberglass enclosure, you must use one of these three choices (padlock, wire seal, or screw).

For either enclosure type, you may apply tamper-evident tape to the four sensor coupling screws and two rotation set screws to provide evidence of unauthorized sensor adjustments. The four coupling screws also include holes through which you could attach a wire seal.

Figure 1-8: Locations Where Customer Can Apply Tamper-Evident Tape

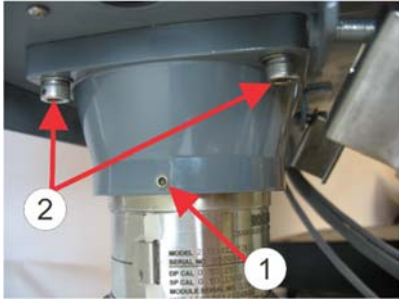

- 1 Rotation Set Screws (2) - One shown
 - 2 Coupling Screws (4) - Two shown
-

Section 2: Installation

This section covers the following topics:

- Hazardous Locations
- Environmental Specifications
- Required Tools
- Site Considerations
- General Wiring Guidelines
- Grounding
- Opening/Closing the Enclosure
- Mounting the Enclosure
- Power Modes
- Connecting Power
- Installing the Optional 30W Solar Panel
- Adjusting the Optional Solar Panel
- Connecting Communications Ports
- Door Contact Terminal

The flow computer ships from the factory fully assembled, except for the optional solar panel assembly.

2.1 Hazardous Locations

For North America the FB2200 has certifications for Class I Division 2 (Groups A, B, C & D) non-incendive, and non-hazardous locations only. [Appendix A](#) contains special information for Class I Division 2 installations.

For other world areas the FB2200 has ATEX and IEC Ex certifications for Ex nA Zone 2 non-sparking installations and non-hazardous locations only. See [Appendix B](#) for more information.

All certifications are listed on the data plate located on the top of the device.

2.2 Environmental Specifications

This section summarizes the environmental specifications for the device. For full details, refer to the product data sheet [FB2200 Flow Computer](#) (D301792X012).

Table 2-1: Environmental Specifications

Specification	Range		
Ambient Temperature	Configuration	Aluminum Enclosure	Fiberglass Enclosure
	No Battery, C1D2	-40 °C to 80 °C (-40 °F to 176 °F)	-35 °C to 80°C (-31 °F to 176 °F)
	No Battery, C1D2, Relay installed	-40 °C to 60 °C (-40 °F to 140 °F)	-35 °C to 60°C (-31 °F to 140 °F)
	Lead Acid Battery, C1D2	-40 °C to 45°C (-40 °F to 113 °F)	-35 °C to 45°C (-31 °F to 113 °F)
	ATEX/IEC Ex nA No Battery	-25 °C to 55°C (-13 °F to 131 °F)	-25 °C to 55°C (-13 °F to 131 °F)
Humidity	5% to 95% non-condensing		
Vibration	2g over 10 to 150 Hz; 1g over 150 to 200 Hz		

2.3 Required Tools

Certain tools and equipment are required for installing and servicing the flow computer.

Table 2-2: Required Tools

Tool	Use
Torque wrench	For bolting/mounting the flow computer
2.5 mm hexagonal wrench	For manipulating rotation set screw
High-wattage soldering iron and solder	For tinning ground connection wire
#1 Phillips-head screwdriver	For screws on HMI module
#2 Phillips-head screwdriver	For screws on other modules and boards
#3 Phillips-head screwdriver	For optional aluminum enclosure clamps
1/8 inch flat-head screwdriver	For 5.08 mm pitch terminal block connections
7/32 inch flat-head screwdriver	For installing external solar controller
Utility knife	For installing external solar controller
Wire cutters	For installing external solar controller
Wire strippers	For installing external solar controller
Laptop PC running Field Tools with FBxConnect configuration software	Software configuration

2.4 Site Considerations

The flow computer must reside in an accessible location for configuration and service. Refer to the dimensional drawings for information on the space required.

- Ensure the installation location provides easy access to the HMI module.
- If your unit includes the optional solar panel, ensure the installation location provides sufficient space to mount the solar panel and adequate sunlight to charge the battery.
- If your unit includes the optional Mobile SCADA ensure the installation location provides line-of-sight access to the transceiver.

Figure 2-1: FB2200 Dimensions – Multivariable Sensor Version - Fiberglass Enclosure

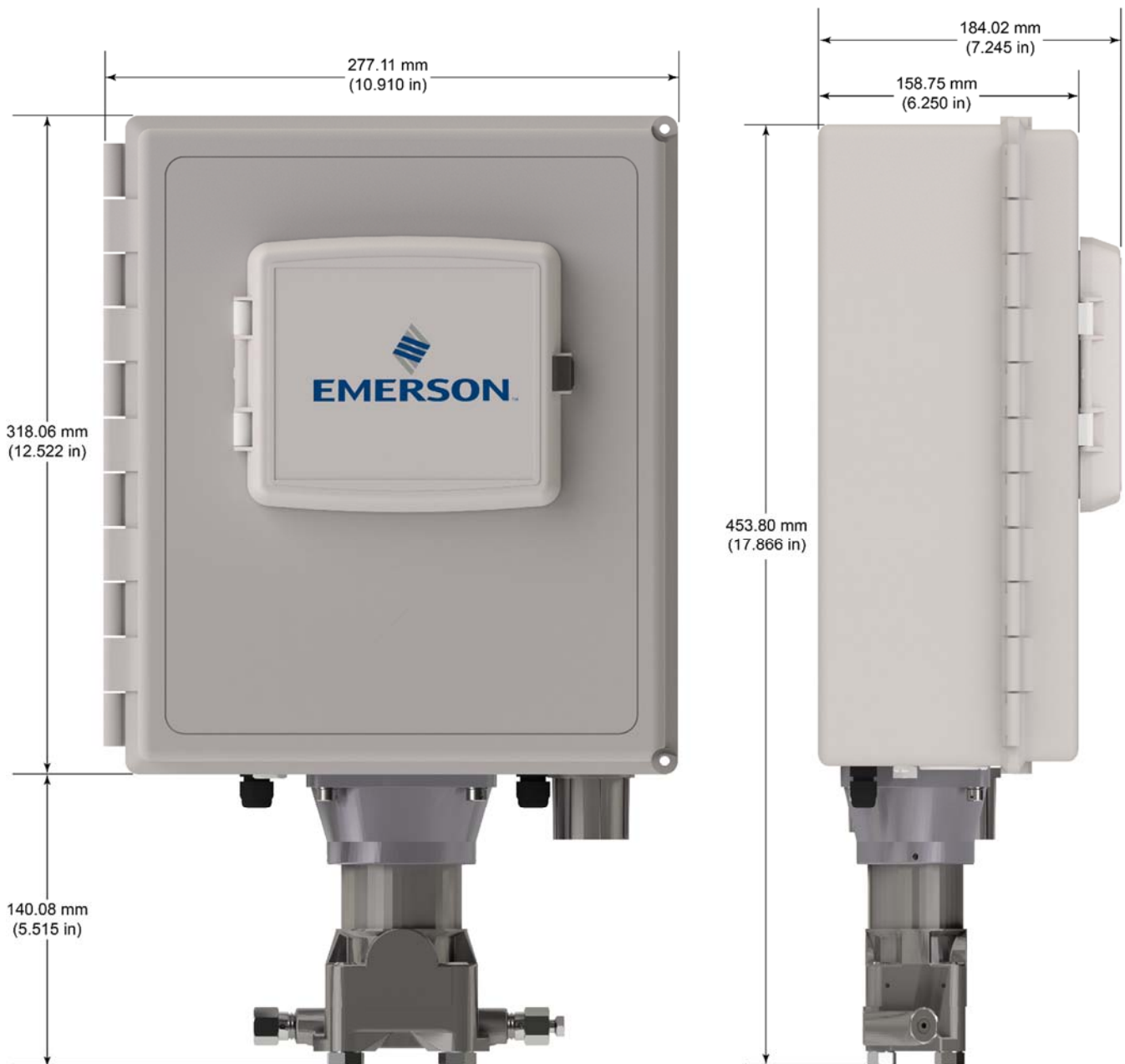

Figure 2-2: FB2200 Dimensions – Multivariable Sensor Version - Aluminum Enclosure



Figure 2-3: FB2200 Dimensions – No Integral Sensor Version – Fiberglass Enclosure



Figure 2-4: FB2200 Dimensions – No Integral Sensor Version – Aluminum Enclosure

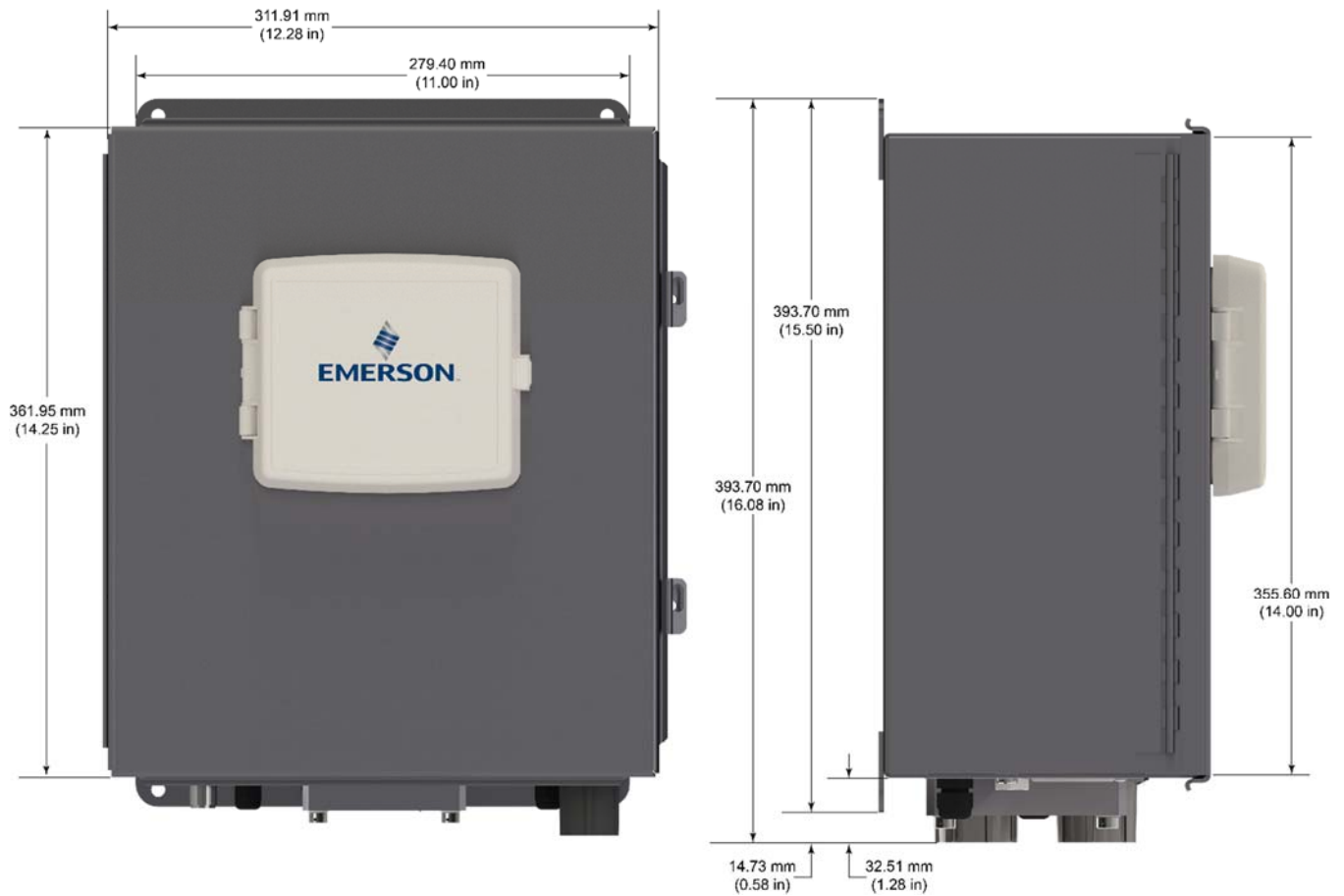
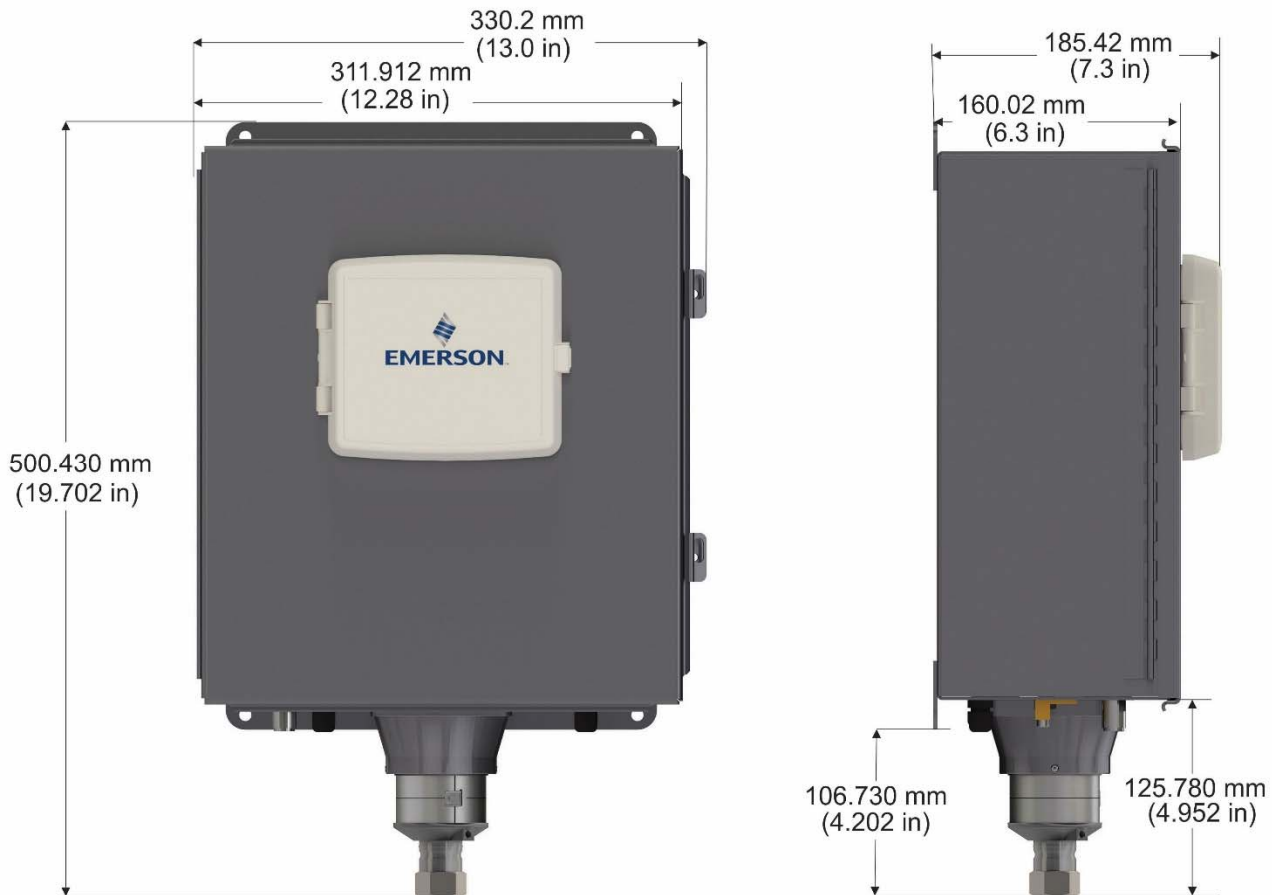

Figure 2-5: Dimensions – Static Pressure Sensor Version – Fiberglass Enclosure



Figure 2-6: Dimensions – Static Pressure Sensor Version – Aluminum Enclosure



2.5 General Wiring Guidelines

The flow computer's pluggable terminal blocks use compression-type terminals that accommodate wire between 28 and 12 AWG.

- When making a connection, insert the bare end of the wire (approx. 1/4" max) into the clamp adjacent to the screw and secure the screw.
- To prevent shorts, ensure that no bare wire is exposed. If using stranded wire, tin the bare end with solder to prevent flattening and improve connectivity.
- Allow some slack in the wire while making terminal connections. Slack makes the wires more manageable and helps minimize mechanical strain on the terminal blocks.
- Use twisted pair, shielded and insulated cable for communication and I/O wiring to minimize signal errors caused by electromagnetic interference (EMI), radio frequency interference (RFI) and transients. When using shielded cable, ground all shields at only one point in the appropriate system. This prevents circulating ground current loops that can cause signal errors.

2.6 Grounding

The flow computer includes a ground stud on the bottom of the battery compartment.

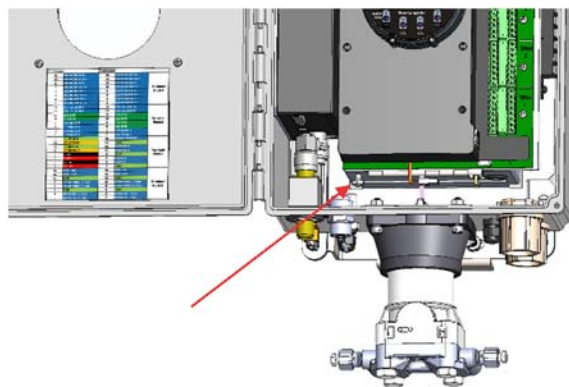

- Once you have installed the unit, run a ground wire between the ground stud on the bottom of the battery compartment and a known good earth ground. You route the ground wire through one of the conduit fittings.
- Use stranded copper wire to earth ground, and keep the length as short as possible.
- Clamp or braise the ground wire to the ground bed conductor (typically a stranded copper AWG 0000 cable installed vertically or horizontally).
- Using a high-wattage soldering iron, tin the wire ends with solder before you insert them into the chassis ground lug.
- Run the ground wire so that any routing bend in the cable has a minimum radius of 30.48 cm (12 inches) below ground and 20.32 cm (8 inches) above ground.

For more information on grounding or if your installation uses cathodic protection, refer to *Site Considerations for Equipment Installation, Grounding, and Wiring (D301452X012)*.

2.7 Opening/Closing the Enclosure

The enclosure opens/closes differently depending upon whether you have the fiberglass enclosure or the aluminum enclosure.

⚠ DANGER

EXPLOSION HAZARD: Never remove cover(s) in a hazardous location. Removing cover(s) in a hazardous location could result in an explosion.

- **Fiberglass Enclosure**
The enclosure includes two fasteners at the top and bottom of the door. To open the door, lift the clasp to loosen the latch and pull it free of the post, then repeat for the other fastener and open the door. To fasten the door, place the latch on the post and press down the clasp; repeat for the other fastener.

Figure 2-7. Fiberglass Enclosure Fasteners



- Aluminum Enclosure

The enclosure includes six clamps along the edge of the door (two at the top, two on the bottom, two at the side). To open the door, use a Phillips head screwdriver to loosen (but not remove) the screws enough so you can then pop the clamp free of the lip of the door, then repeat for the other clamps and open the door. To fasten the door, place the clamp over the door lip then tighten the screw torquing to 20 in-lbs (2.3 N m); repeat for the other clamps.

Figure 2-8. Aluminum Enclosure Clamps



2.8 Mounting the Enclosure

You can mount the flow computer directly to a pole. You can also mount it on a wall or panel.

2.8.1 Bolting Considerations

If the flow computer installation requires assembly of a process flange, manifold, or flange adapters, follow these assembly guidelines to ensure a tight seal for optimal performance characteristics of the flow computer.

Only use bolts supplied with the flow computer or sold by Emerson Remote Automation Solutions as spare parts. Refer to the figure for common flow computer assemblies with the bolt length required for proper flow computer installation.

⚠ DANGER

EXPLOSION HAZARD: Ensure the area in which you perform this operation is non-hazardous. Performing this operation in a hazardous area could result in an explosion.

Note

For all other manifolds, contact your Emerson Local Business Partner (LBP).

Bolts are typically carbon steel or stainless steel. Confirm the material by viewing the markings on the head of the bolt and referencing the figure. If bolt material is not shown in the figure, contact your local Emerson Remote Automation Solutions representative for more information.

Figure 2-9. Transmitter with Coplanar Flange

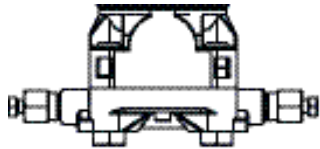

4 x 1.75 in (44 mm)

Figure 2-10. Transmitter with Coplanar Flange and Optional Flange Adapters

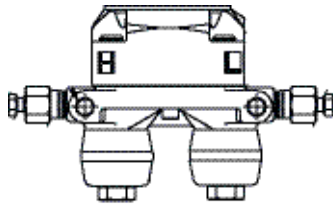

4 X 2.88 in (73 mm)

Figure 2-11. Transmitter with Traditional Flange and Optional Flange Adapters

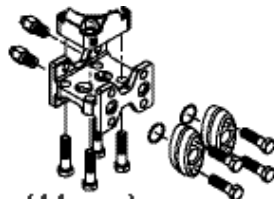

4 x 1.75 in (44 mm)

4 x 1.50 in (38 mm)

Use the following bolt installation procedure:

1. Carbon steel bolts do not require lubrication. Stainless steel bolts are factory-coated with a lubricant to ease installation. Do not apply any additional lubricant when installing either type of bolt.

2. Finger-tighten the bolts.
3. Torque the bolts to the initial torque value using a crossing pattern. See Table 2-3 for initial torque value.
4. Torque the bolts to the final torque value using the same crossing pattern. See Table 2-3 for final torque value.
5. Verify that the flange bolts protrude through the sensor module before applying pressure.

Table 2-3: Torque Values for the Flange and Flange Adapter Bolts







Bolt Material	Head markings	Initial Torque	Final Torque
Carbon Steel (CS)	 	300 in. -lbs. (33.9 N m)	650 in. -lbs. (73.4 N m)
Stainless Steel (SST)	     	150 in. -lbs. (16.9 N m)	300 in. -lbs. (33.9 N m)

Figure 2-12. Proper Bolt Installation

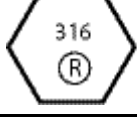
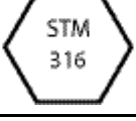

- 1 Bolt
- 2 Sensor module

2.8.2 O-rings with Flange Adapters

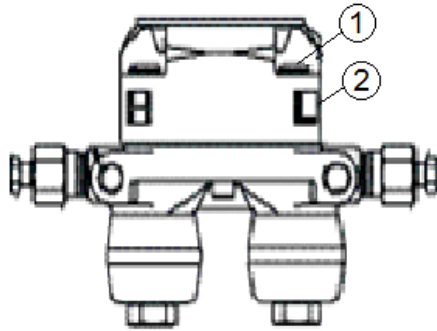
⚠ DANGER

Failure to install proper flange adapter O-rings may cause process leaks, which can result in death or serious injury. Only use the O-ring that is designed for its specific flange adapter.

Figure 2-13. O-rings with Flange Adapters

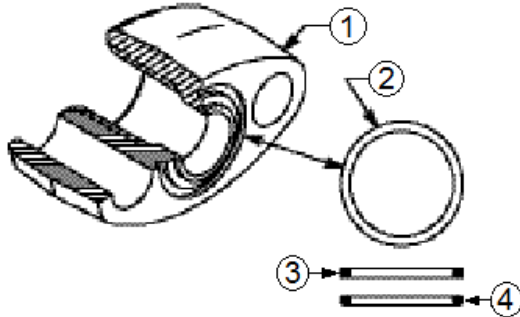

- 1 Flange
- 2 O-ring
- 3 Square PTFE-based profile
- 4 Round Elastomer profile

1. Whenever the flange or adapters are removed, visually inspect the O-rings.
2. Replace the O-rings if there are any signs of damage, such as nicks or cuts.
3. If the O-rings are replaced, re-torque the flange bolts and alignment screws after installation to compensate for seating of the O-rings.

2.8.3 Pole Mounting – Aluminum Enclosure

Refer to *Figure 2-14* during the mounting procedure.

1. Apply Loctite® 222™ Low Strength Purple Threadlocker sparingly to threads of head cap screws (Item 2).
2. Attach pole mounting brackets (Item 3) to enclosure using head cap screws (Item 2) and hex nuts (Item 1). Torque hex nuts to 30 in-lbs (3 N m).
3. Apply Loctite 222 threadlocker sparingly to threads of U-bolts (Item 4).
4. Use U-bolts (Item 4) to mount enclosure to pole using hex nuts (Item 1). Torque hex nuts to 30 in-lbs (3.4 N m).

Figure 2-14: Aluminum Enclosure Pole Mounting

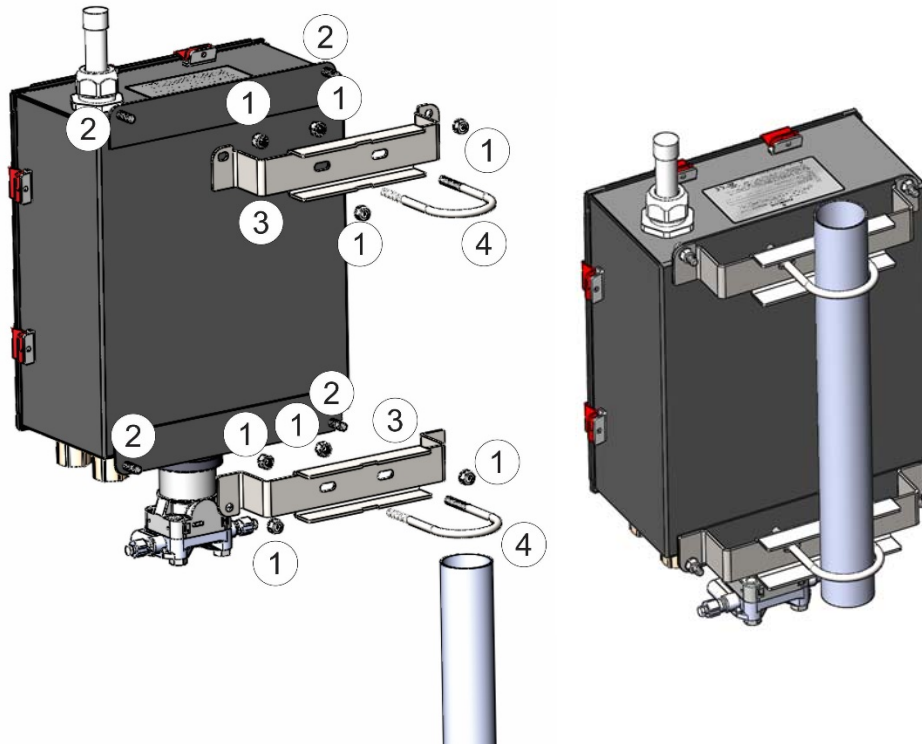

- 1 5/16-18 keps stainless steel hex nut
- 2 5/16-18 x 1.0 LG wire-lockable socket head cap screw
- 3 Pole mounting bracket
- 4 2-inch diameter 5/16-18 x 4.0LG U-bolt

2.8.4 Pole Mounting – Fiberglass Enclosure

Refer to *Figure 2-15* during the mounting procedure.

1. Attach plastic pole mounting brackets (Item 4) to enclosure using split lock stainless steel washers (Item 1) and torx head screws (Item 2).
2. Apply Loctite® 222™ Low Strength Purple Threadlocker sparingly to threads of U-bolts (Item 5).
3. Use U-bolts (Item 5) to mount enclosure to pole using hex nuts (Item 3). Torque hex nuts to 30 in-lbs (3.4 N m).

Figure 2-15. Fiberglass Enclosure Pole Mounting

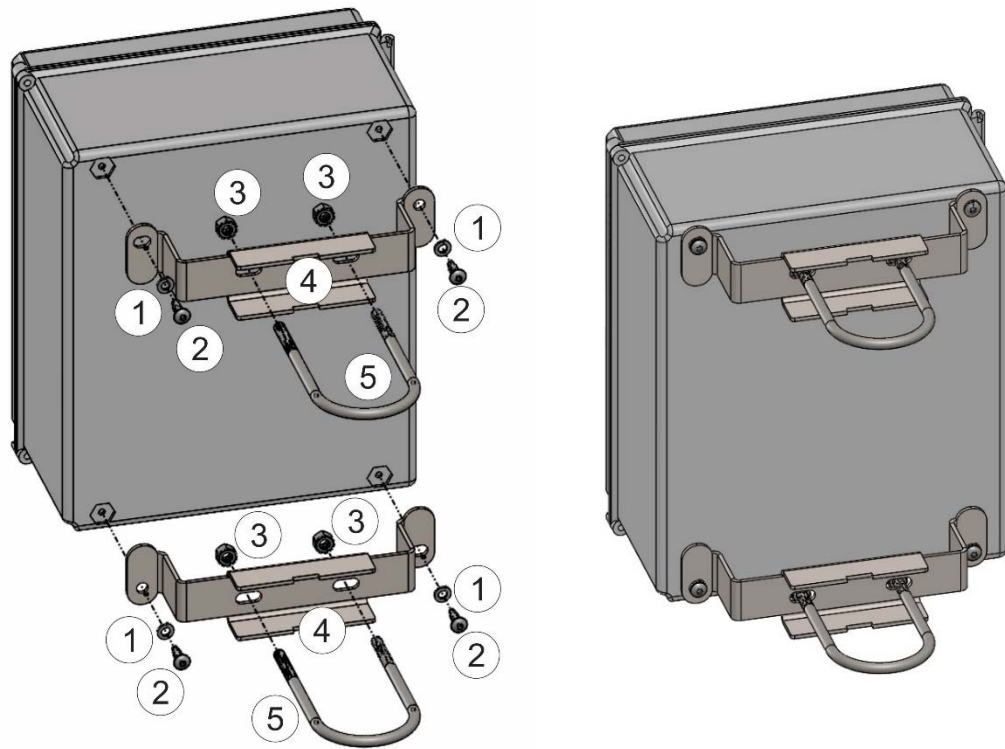

- 1 ¼ inch screw split lock stainless steel washer
- 2 ¼-10 x .75LG thread forming torx head screw
- 3 5/16-18 keps stainless steel hex nut
- 4 pole mounting bracket
- 5 2 inch diameter 5/16-18 x 4.0LG U-bolt

2.8.5 Panel/Wall Mounting Dimensions – Aluminum Enclosure

Figure 2-16: Aluminum Enclosure Panel/Wall Mounting

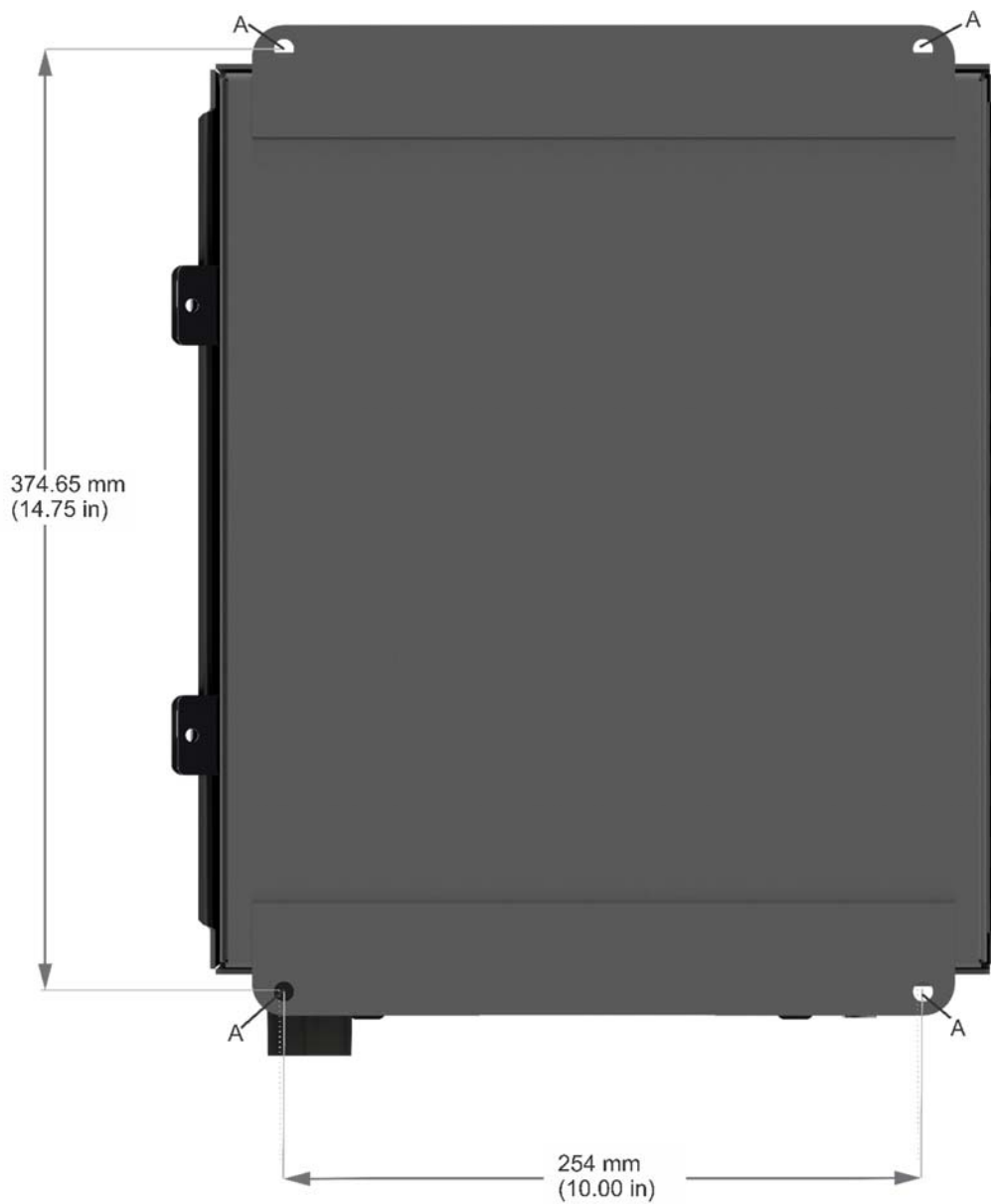

A Mounting holes are 7.92 mm (0.312 in) diameter

2.8.6 Panel/Wall Mounting Dimensions – Fiberglass Enclosure

Prior to mounting, attach mounting tabs to enclosure:

Figure 2-17: Attaching mounting tabs

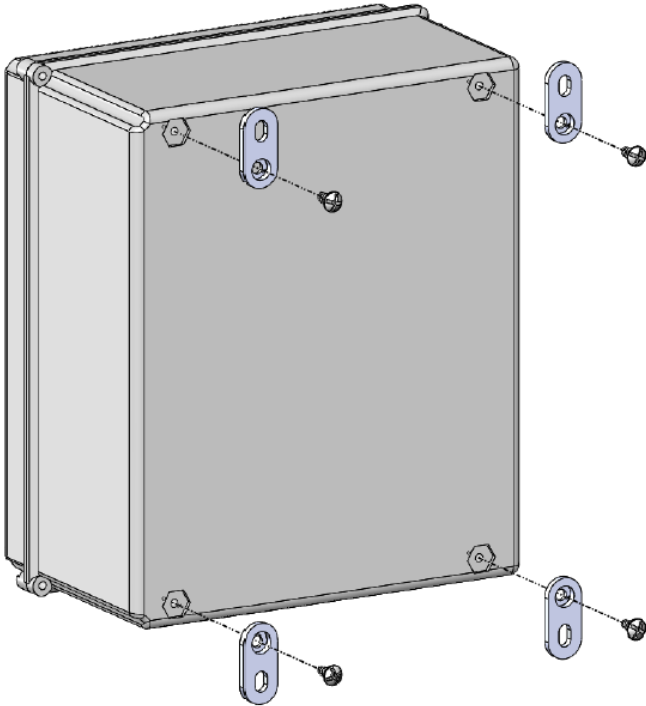
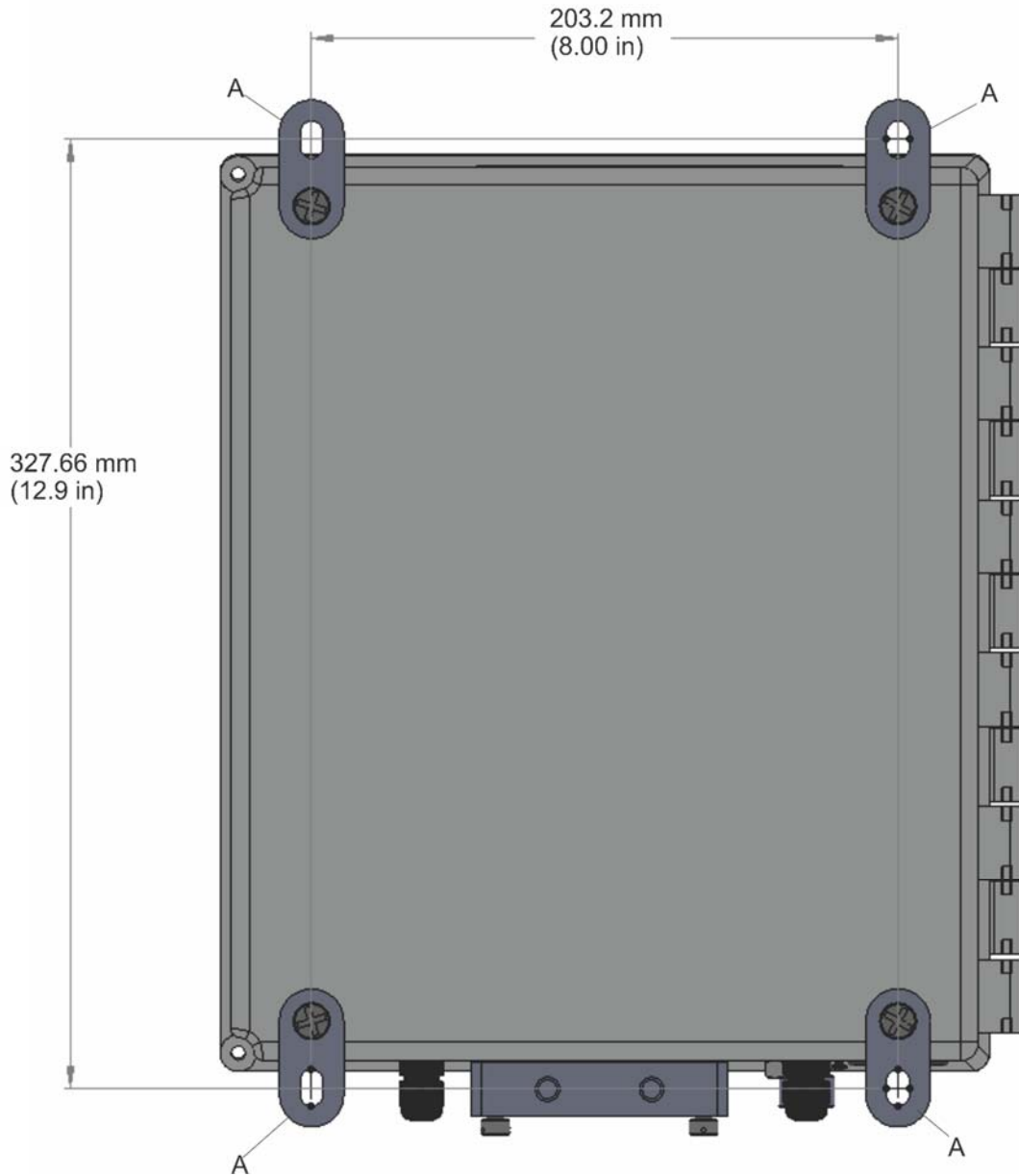

Figure 2-18: Fiberglass Enclosure Panel/Wall Mounting



A Mounting holes are 7.9 mm (0.31 in) wide

2.8.7 Rotating the Housing

To improve accessibility to the HMI module or to ease wiring, you can optionally rotate the housing.

Important

Never rotate the housing more than 180 degrees from its original (as-shipped) position. Over-rotation can break electronics within the unit.

Figure 2-19: Housing Rotation Set Screw (1 each side)



1 Set Screw (one each side)

⚠ DANGER

EXPLOSION HAZARD: Ensure the area in which you perform this operation is non-hazardous. Performing this operation in a hazardous area could result in an explosion.

1. Loosen the two housing rotation set screws.
2. Rotate the housing **no more than** 180 degrees from its original (as-shipped) position.
3. Re-tighten the two housing rotation set screws. Torque to 6 in-lbs. (0.7 N m).

2.9 Power Modes

To keep power consumption to a minimum, especially for remote sites, the FB2200 can run in two different power modes – Low Power Mode (4 or 8 MHz CPU clock speed) or Standard Power Mode (60 MHz CPU clock speed).

2.9.1 Low Power Mode

The FB2200 normally runs in low power mode for typical metering applications. The radio Power Control function (configurable in FBxConnect) switches the flow computer into standard power mode at specified times when serial communications are required, then it reverts to low power mode when the communication period is over. A serial connection to a remote 4088B MVT can occur in low power mode.

The local display (HMI module) with Mobile SCADA and Wi-Fi uses additional power. You can configure it in FBxConnect to shut down after a period of inactivity.

Table 2-4: Typical Power Usage – Low Power Mode at Room Temperature

Description	Power Usage (mW) at 12.3Vdc
Base flow computer with integral multivariable DP and pressure sensor and temperature measurement, single DO available, for a single meter run Historical configuration supports maximum of: <ul style="list-style-type: none"> • 4 averages • 12 Station 1 history points (Group 4) • 10 User Periodic history points (Group 1) 	55
Base flow computer with integral multivariable DP and pressure sensor and temperature measurement, 2 digital and 2 analog channels available for a single meter run Historical configuration supports maximum of: <ul style="list-style-type: none"> • 4 averages • 12 Station 1 history points (Group 4) • 10 User Periodic history points (Group 1) 	67
Base flow computer with integral multivariable DP and pressure sensor and temperature measurement, communicating to remote 4088B-dual meter run (4088B externally powered) Historical configuration supports maximum of: <ul style="list-style-type: none"> • 8 averages • 24 Station 1 & Station 2 history points (Group 4/Group 5) • 10 User Periodic history points (Group 1) 	120
Additional Load Options:	
Mobile SCADA and display active	398
DO active (1 Hz, 50:50 duty cycle, no load)	12
PI active (10 KHz, 50:50 duty cycle, square wave)	12

Important

If you increase the number of history points/averages beyond any of the maximum limits in [Table 2-4](#), the flow computer **cannot** operate in low power mode and automatically runs in standard power mode.

2.9.2 Standard Power Mode

When serial communication is active (other than to a remote 4088B MVT) the FB2200 operates in standard power mode. The unit also uses standard power mode when:

- The HMI module display is ON
- Wi-Fi is active

- Ethernet port enabled in the flow computer
- Modbus Master communication is active
- PIDs, Math/logic Blocks, Action Blocks, Effect blocks enabled
- Expansion I/O board(s) installed in the flow computer
- Power control zone enabled

Table 2-5: Typical Power Usage – Standard Power Mode at room temperature

Description	Power Usage (mW) at 12Vdc	Power Usage (mW) at 24Vdc
Base flow computer with integral multivariable DP and pressure sensor and temperature measurement for a single meter run	240	290
Base flow computer with temperature measurement (no integral sensor) communicating to remote 4088B (externally powered) for a single meter run	220	268
Base flow computer with integral multivariable DP and pressure sensor and temperature measurement, 2 digital and 2 analog channels available for a single meter run	260	313
Base flow computer with temperature measurement, integral static pressure sensor and pulsed input for a single meter run	276	330
Base flow computer with integral multivariable DP and pressure sensor and temperature measurement, communicating to remote 4088B (externally powered) for a dual meter run	250	300
Additional Load Options:		
Display and backlight active	159	188
Mobile SCADA active	191	199
Mobile SCADA and display active	233	245
DO active (1 Hz, 50:50 duty cycle, no load)	20	23
PI active (10 KHz, 50:50 duty square wave)	14	15
8-channel expansion I/O board installed (isolated)	228	280
Additional 6-channel expansion I/O board installed (isolated)	68	66
Ethernet enabled 100 Mbit	430	466
Ethernet active 100 Mbit	640	650
Loop power supply	310	393

2.9.3 Notes on Battery Life

Battery life varies based on numerous factors including temperature, communication usage, and various load options. To achieve the maximum battery life noted in the product data sheet requires that you:

- Limit use of the display, backlight, and Mobile SCADA (Wi-Fi) options.

- Limit communication activity.
- Disable power to all I/O (except for the MV or static pressure sensor, or RTD). To do this, click **Configure > I/O Setup > I/O Configuration > Properties** and select **Disable** for each I/O module.

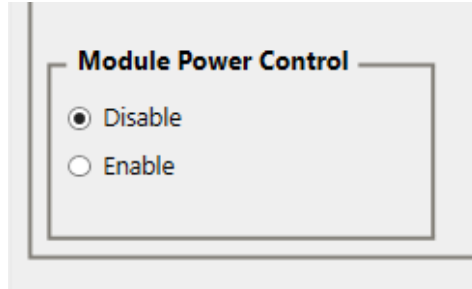

2.10 Connecting Power

Power can come from an external DC supply, or a lead acid battery pack with a solar panel.

2.10.1 Connecting DC Power

⚠ DANGER

EXPLOSION HAZARD: Ensure the area in which you perform this operation is non-hazardous. Performing this operation in a hazardous area could result in an explosion.

When power comes from an external DC supply, connect using the +DCIN and –DCIN terminals. Use standard copper wire (#18 AWG minimum). The device supports both 12V and 24V power supplies. It accepts DC voltage from 10.5 to 30V; the amount of power required varies depending upon the options used.

Important

If your installation uses DC power for main power, **do not** wire battery power as a secondary or “back up” power source. Certification only allows a single main power source; wiring both sources **will void your certification**.

Figure 2-20. DC Power Connections

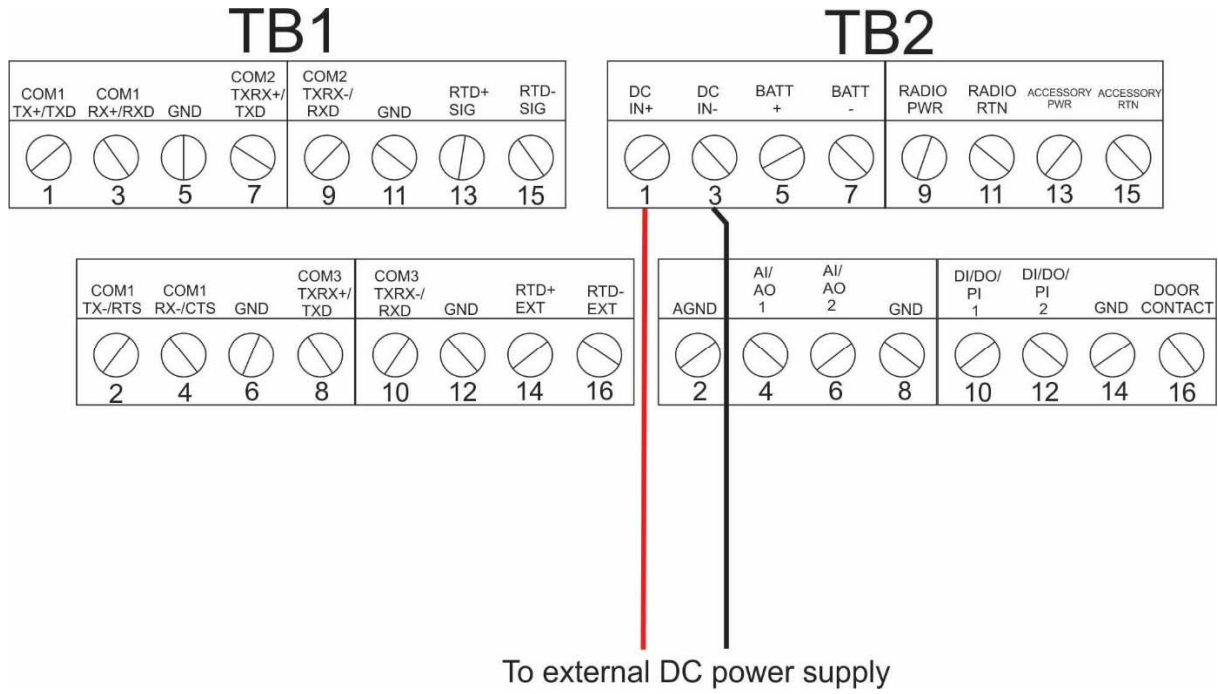

2.10.2 Connecting Battery Power

⚠ DANGER

EXPLOSION HAZARD: Ensure the area in which you perform this operation is non-hazardous. Performing this operation in a hazardous area could result in an explosion.

When power comes from an internal battery pack, the battery pack plugs into one of two pairs of connectors.

Installing the Main Battery Pack

If you purchased one of the battery/solar panel options, you need to install the main battery pack before you place the device in service.

The device provides a battery cable with two pairs of battery connectors, enabling you to hot-swap the battery pack in a non-hazardous location. You can use either pair of connectors when you install the battery.

1. Remove the battery pack from its packaging.
2. Remove the plastic tabs covering the connectors on the battery pack.

Figure 2-21. Removing Plastic Tabs from Battery Pack

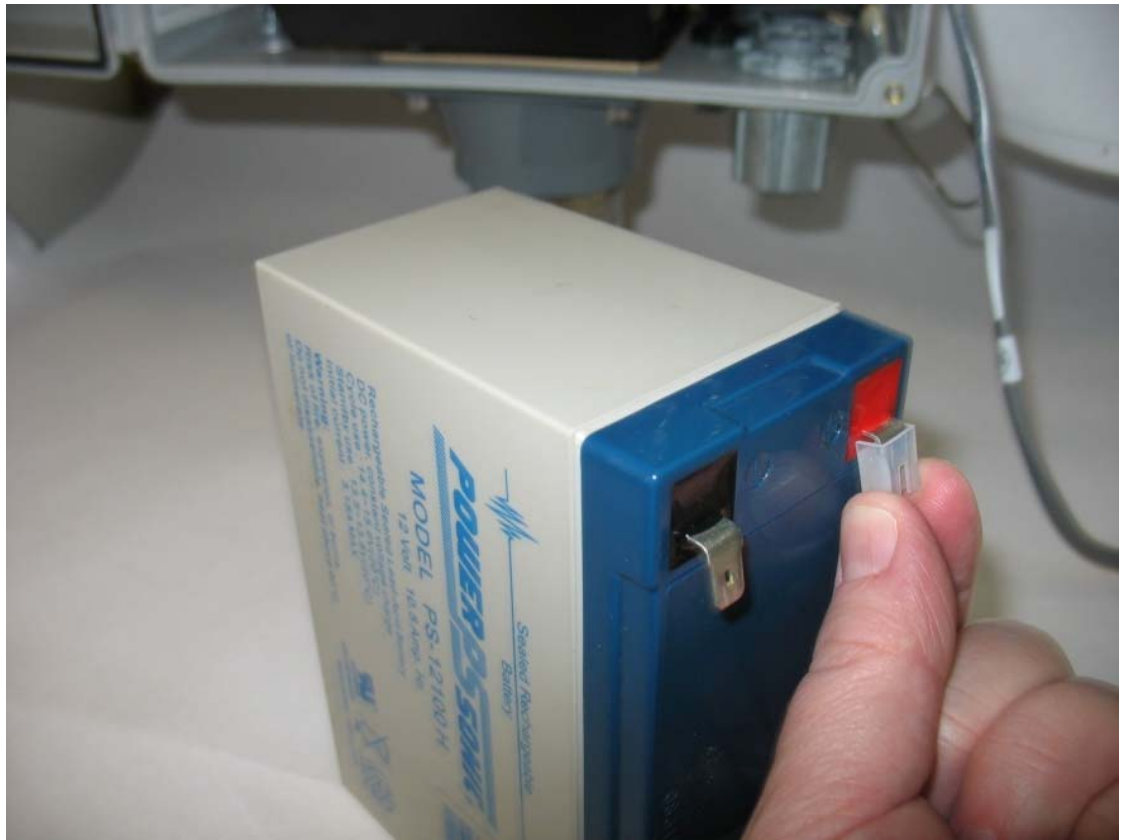

1. Open the enclosure.

2. Loosen the two captive fastening screws at the top of the of the battery compartment, while holding onto the battery compartment door. Carefully rotate the electronics assembly towards you to reveal the inside of the battery compartment. A strap prevents the front of the compartment from rotating too far forward.

Figure 2-22. Captive Fastening Screws

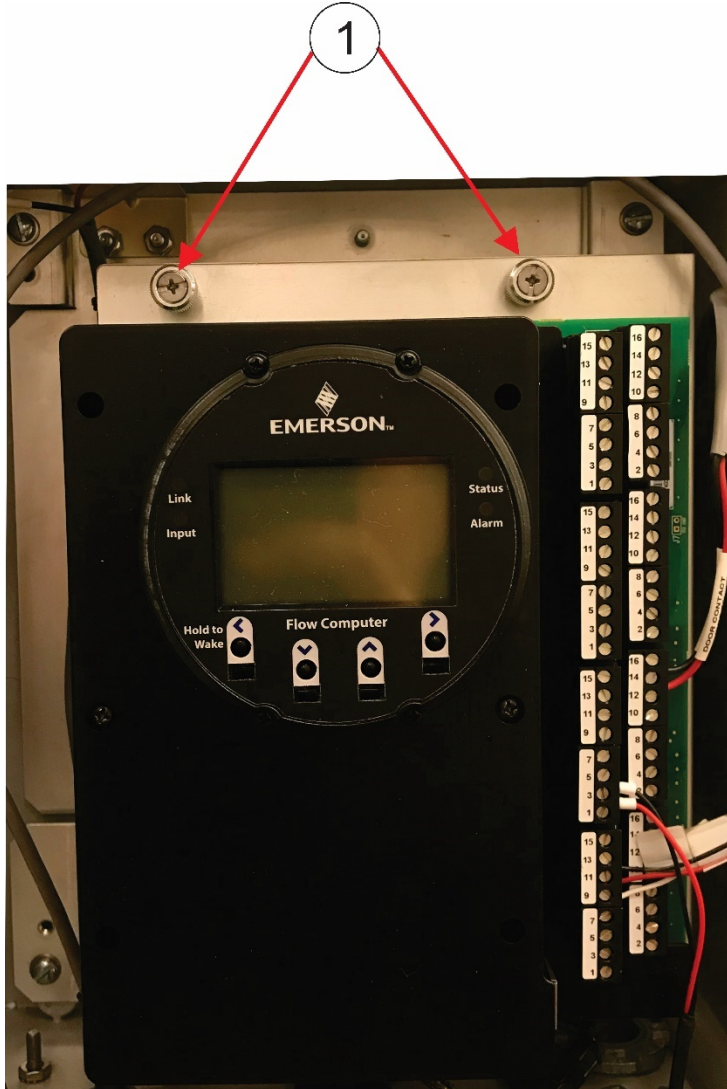

1 Captive Fastening Screws

Figure 2-23. Rotate Assembly Forward



-
3. The battery cable inside the battery compartment is divided into two branches, each with its own pair of connectors. Take either pair of connectors and connect them to the battery; the red (positive) wire connector attaches to the red connection point on the battery and the black (negative) wire connector attaches to the black connection point on the battery.

Figure 2-24. Connect the Battery



4. Now you must secure the battery in the battery compartment so that it doesn't move around. How you do this depends on which battery compartment configuration you have. If the battery compartment includes a strap for holding the battery, see *Securing the Battery with a Strap*; if the battery compartment includes a hook and loop pad, see *Securing the Battery to the Pad*.

Securing the Battery with a Strap

This type of battery compartment allows for certain accessories to be installed such as a relay or internal solar regulator.

1. If you have an internal solar regulator installed in the battery compartment, you must remove its termination cover in order to fit the battery inside. Remove the two screws (left and right) that fasten the termination cover to the solar regulator, and then set the termination cover aside. (If you don't have an internal solar regulator, skip to Step 2.)

Figure 2-25: Removing Termination Cover of Internal Solar Regulator

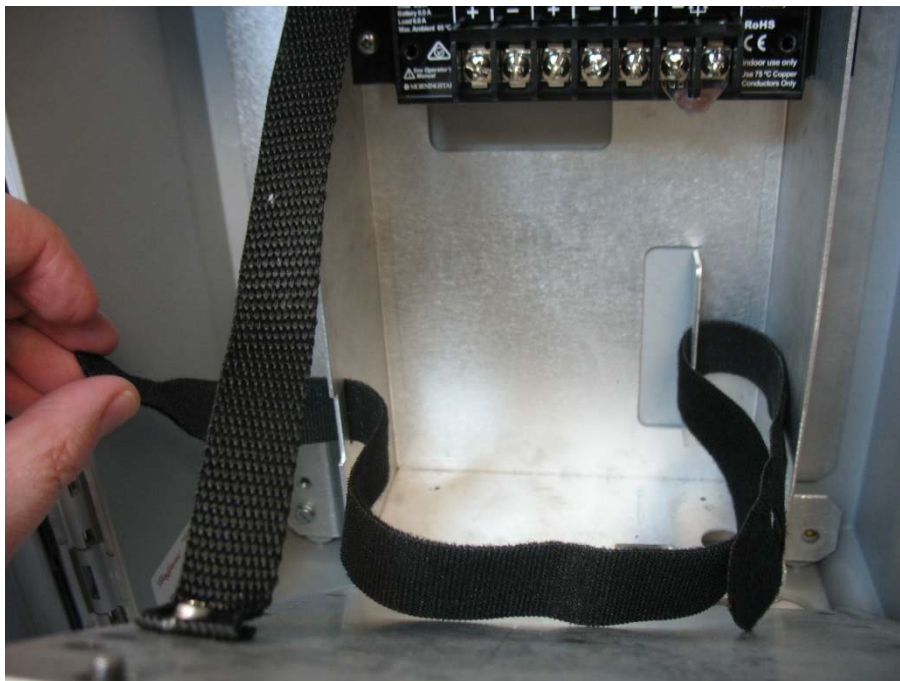

2. The battery strap must already be threaded through the holes of the battery compartment.

Figure 2-26: Battery Strap

3. Pick up the battery and carefully ease it into the battery compartment with the writing on the battery facing out and the connectors on the upper right-hand side. Nothing (including the strap) can be behind the battery.

Figure 2-27: Easing Battery Pack into Compartment



4. Carefully push the battery under the solar regulator (if present) and against the back of the compartment, now strap it in tightly by pulling the ends of the strap.

Figure 2-28: Battery Pack Attached to Compartment



5. The strap includes a narrow opening into which you can slide the other end of the strap to help you tighten it.

Figure 2-29: Battery Pack Attached to Compartment



6. Route the extra portion of the strap as well as the wires of the free portion of the battery cable so that they sit in an open area of the battery compartment.
7. If you had to remove the termination cover of an internal solar regulator (Step 1), re-attach the termination cover.
8. Rotate the electronics assembly up against the battery compartment and tighten the captive fastening screws with a torque value of 2 to 4 in-lbs. (0.2 to 0.5 N m) to close the compartment.

Securing the Battery to the Pad

For this type of battery compartment, a hook-and-loop pad on the back of the battery secures it to the back of the battery compartment.

1. Pick up the battery and align it with the lower left edge of the battery compartment. Press it against the back of the compartment so the pad on the back of the battery secures to the back of the battery compartment.

Figure 2-30: Battery Pack Attached to Compartment



2. Route the wires of the free portion of the battery cable so that they sit completely inside the open area at the top of the battery compartment.
3. Rotate the electronics assembly up against the battery compartment and tighten the captive fastening screws with a torque value of 2 to 4 in-lbs (0.2 to 0.5 N m) to close the compartment.
4. Close the enclosure.

2.10.3 Connecting Solar Power

DANGER

EXPLOSION HAZARD: Ensure the area in which you perform this operation is non-hazardous. Performing this operation in a hazardous area could result in an explosion.

Restriction

The solar panel and lead acid battery combination cannot be used with ATEX/IECEX applications.

When power comes from a solar panel/lead acid battery combination, connect using the BATT+ and BATT- terminals and standard copper wire (#18 AWG minimum).

Important

Only use batteries supplied with the flow computer or sold by Emerson as spare parts for this flow computer. If you substitute a battery you obtain elsewhere **you will void your certification unless it is the identical part from the same manufacturer** as that supplied with the flow computer from Emerson.

Important

If you purchase a solar panel/external solar regulator combination other than the Emerson-approved option, it must meet the specifications listed in *Tables 2-6* and *2-7*.

Wiring the 30W Solar Panel

For the 30W solar panel option with an external solar controller (charger/regulator) purchased through Emerson (Emerson-approved option) connect the external solar controller to the flow computer battery using the instructions in this section.

If you are using your own external solar controller/30W solar panel not purchased through Emerson, you can use this section as an example of a typical installation. You should also consult the manufacturer's instructions for your solar panel/solar regulator.

In either situation, you must use the battery, cables, and fuses supplied by Emerson for your connections to the solar controller/solar panel.

Note

When making connections to the junction box or the solar regulator, you will need a suitable cable gland/grommet to prevent water ingress to the junction box.

See *Figure 2-8* for wiring instructions if you ordered the internal solar regulator.

Table 2-6: Solar Panel Electrical Characteristics

Characteristic:	Value/Range:
Peak Power	30W ± 10%

Voltage (@peak power)	17.9V
Current (@peak power)	1.68A
Open Circuit Voltage	22.1V
Short Circuit Current	1.74A

Table 2-7: Solar Regulator Electrical Characteristics

Characteristic:	Value/Range:
Rated Solar Input	6A
Nominal System Voltage	12V
Maximum Solar Voltage	30V
3 stage charging	Bulk, PWM, and float
Regulation Voltage	14.1V
Float Voltage	13.7V
Temperature Compensation	30 mV / °C
Operating Temperature	40 °C to 70 °C
Humidity	100%
Electronic Protection	<ul style="list-style-type: none"> •reverse polarity •lightning and transient surges •short circuit •high temperature •overcurrent •reverse current at night

1. The solar controller comes with plastic mounting feet used only for surface mounting applications. Remove the mounting feet, but save the lock nut.
2. The solar controller also comes with fork connectors.

Figure 2-31. Solar Controller

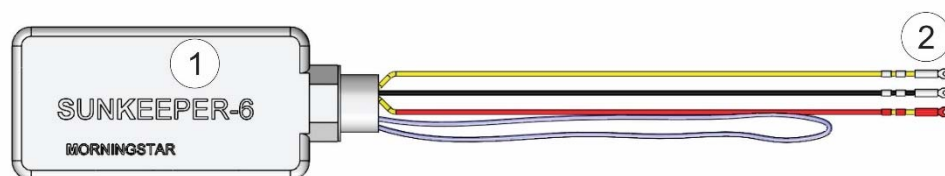

- 1 Solar controller**
- 2 Fork connectors**

3. Remove the fork connectors and trim back the insulation on the wires ¼ inch.

Figure 2-32. Removing Fork Connectors

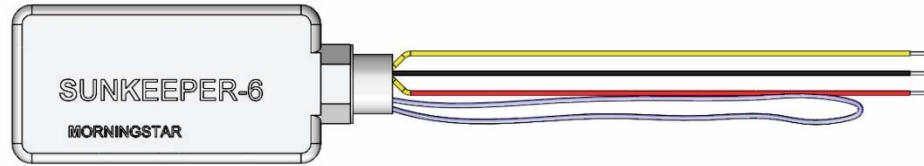

4. Remove the junction box cover. Use a utility knife to remove the knock-outs (Item 2) in the junction box (Item 1) and feed the wires from the solar controller into the junction box, and through the solar controller lock nut (Item 3).

Figure 2-33. Wiring Solar Power – External Regulator

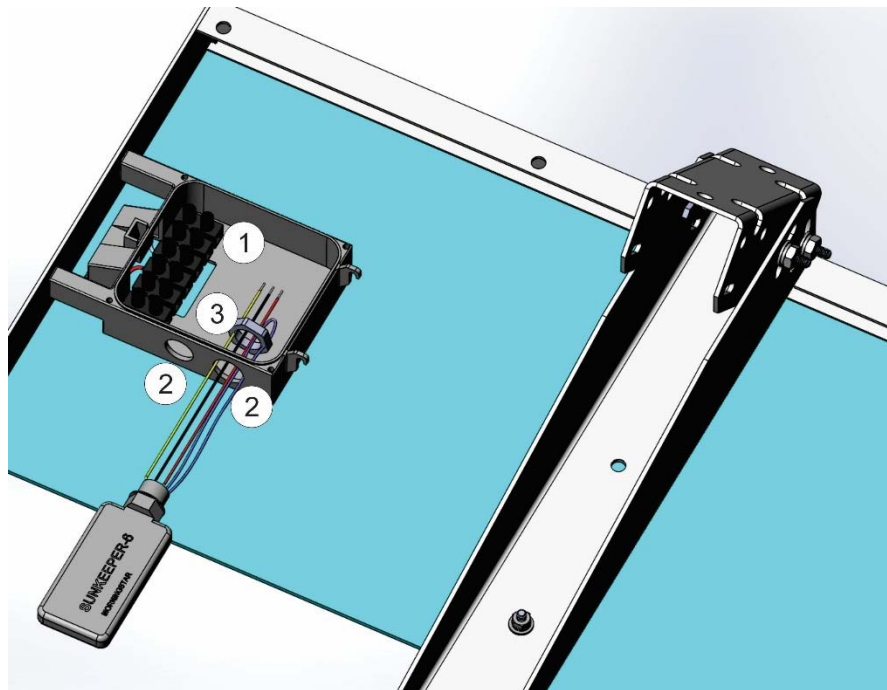

- 1 Junction box
- 2 Knock-outs
- 3 Lock nut

5. Use the solar controller lock nut to attach the solar controller to the junction box, and use a 7/32" flat head screwdriver to attach the wires from the controller to the junction box connectors as shown.

Figure 2-34. Wiring Solar Power – External Regulator

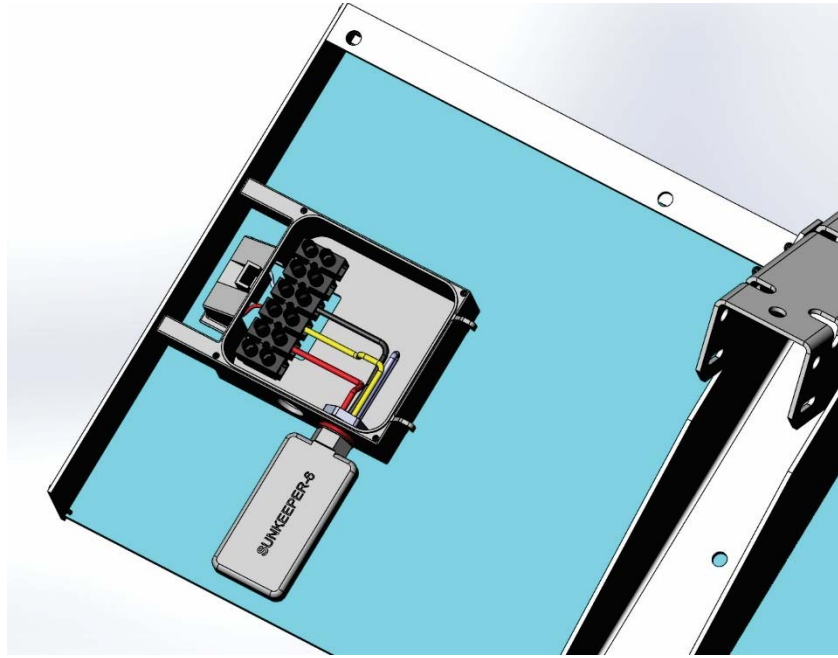

6. Route the BATT+ and BATT- wires from the flow computer into the junction box.

Figure 2-35. Routing Battery Wires

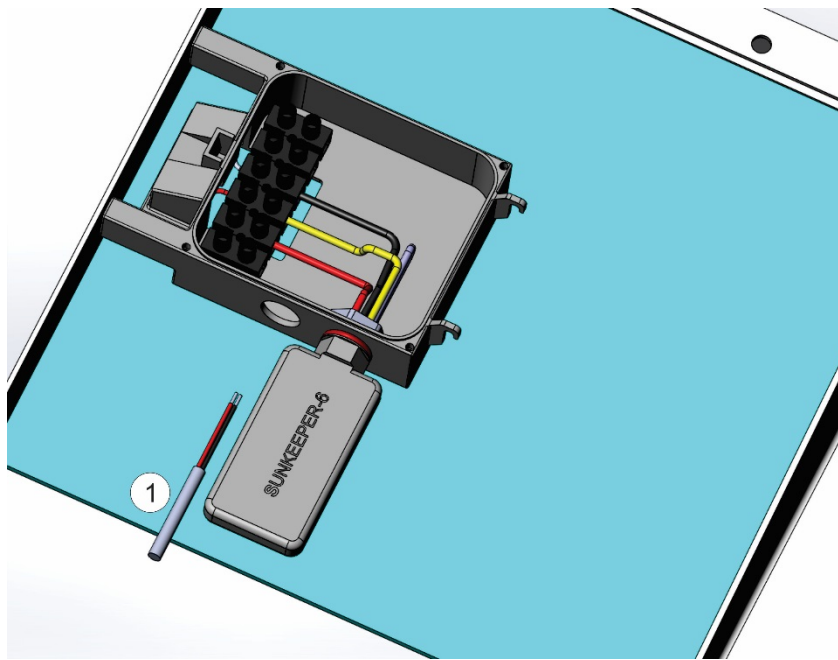

7. Connect the wires as shown. Replace the junction box cover.

Figure 2-36. Wiring Solar Power – External Regulator

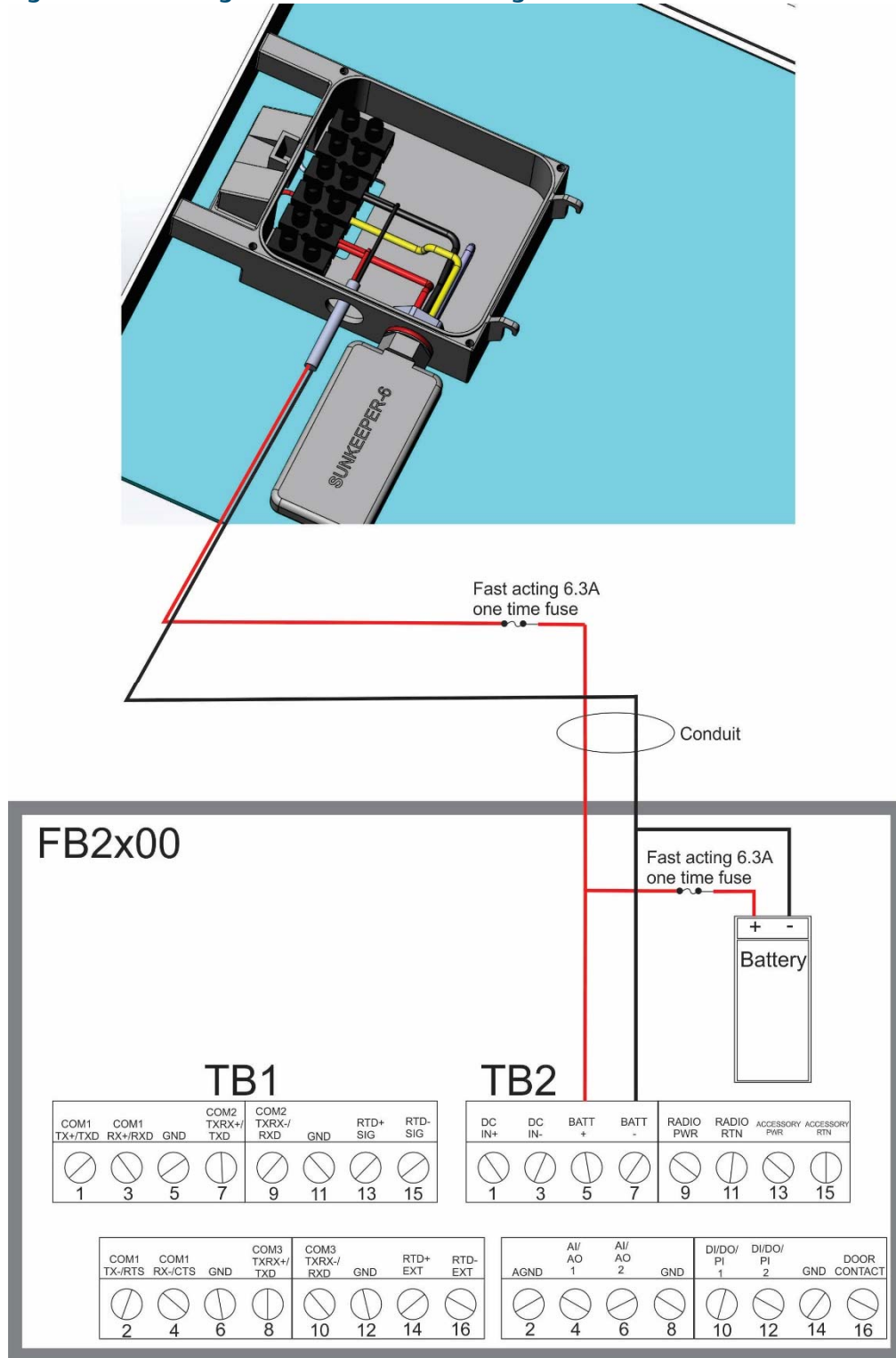

If you ordered the flow computer with an internal solar regulator for the 30W solar panel, wire it according to [Figure 2-37](#).

Figure 2-37. Wiring Solar Power – Internal Regulator

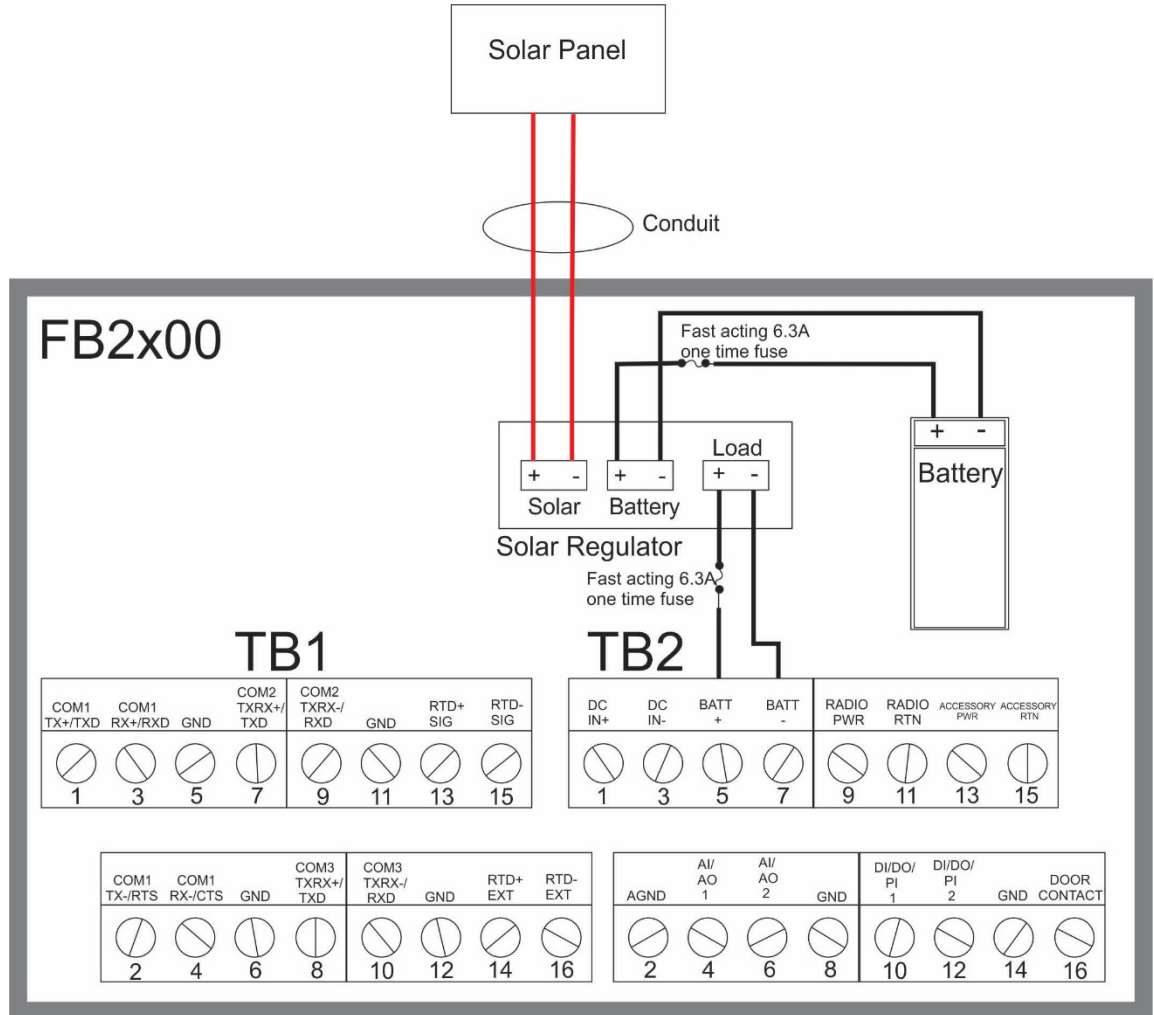

2.11 Installing the Optional 30W Solar Panel

If you purchased the lead acid battery/30W solar panel kit for main power, you need to install the supplied solar panel. Refer to [Figure 2-38](#) during this procedure.

⚠ DANGER

EXPLOSION HAZARD: Ensure the area in which you perform this operation is non-hazardous. Performing this operation in a hazardous area could result in an explosion.

Solar panel installation involves:

- Mounting the solar panel on a pole
- Wiring power to the solar panel. (See [Section 2.10.3](#))
- Setting the tilt angle of the panel for maximum solar exposure. (See [Section 2.13](#))

1. Attach the adjustable angle bracket (Item 2 in *Figure 2-38* to the solar panel (Item 1) using the hex screws (Item 5), flat washers (Item 6), lock washers (Item 7), and hex nuts (Item 8).
2. Torque hex nuts (Item 8) to 60 in-lbs (6.8 N m).
3. Apply Loctite® 222MS™ Purple Threadlocker Low Strength sparingly to hex nut threads (Item 8) after torquing.
4. Attach pole mounting bracket (Item 3) to angle bracket (Item 2) using hex screws (Item 12), flat washers (Item 11), lock washers (Item 10) and hex nuts (Item 9).
5. Torque hex nuts (Item 9) to 108 in-lbs (12.2 N m).
6. Apply Loctite 222MS threadlocker sparingly to hex nut threads (Item 9) after torquing.
7. Attach entire solar panel assembly to pole by attaching pole mounting bracket (Item 3) to U-bolt assembly (Item 4). Torque nuts in U-bolt assembly to 60 in-lbs (6.8 N m).
8. Apply Loctite 222MS threadlocker sparingly to hex nut threads (Item 8) after torquing.

Figure 2-38. Installing 30W Solar Panel

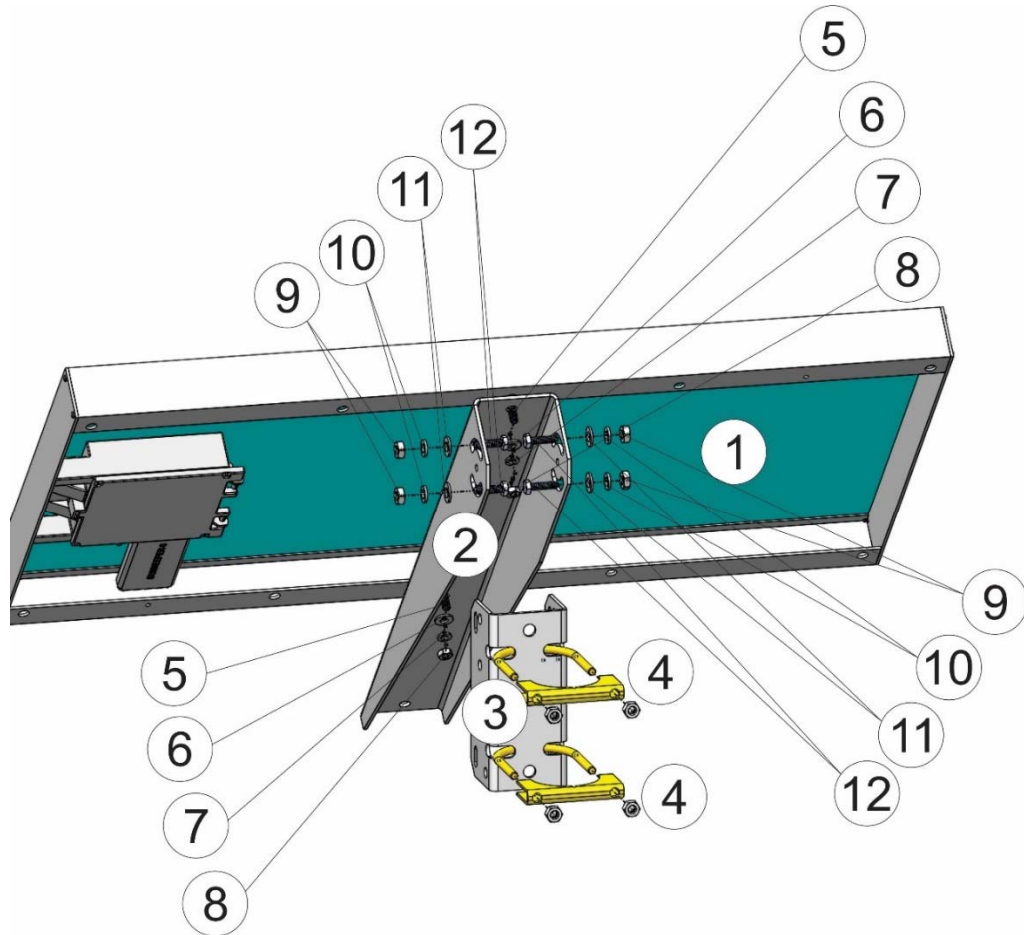

- | | |
|---|--------------------------|
| 1 | 30W solar panel |
| 2 | Adjustable angle bracket |
| 3 | Pole mounting bracket |

- 4 U-bolt assembly (2)
 - 5 ¼ x 20 x .75LG Hex head cap screw (2)
 - 6 ¼ flat washer (2)
 - 7 ¼ lock washer (2)
 - 8 ¼-20 hex nut (2)
 - 9 5/16-18 hex nut (4)
 - 10 5/16 lock washer (4)
 - 11 5/16 flat washer (4)
 - 12 5/16-18 x 0.75 LG Hex head cap screw (4)
-
-

Figure 2-39. 30W Solar Panel Installed

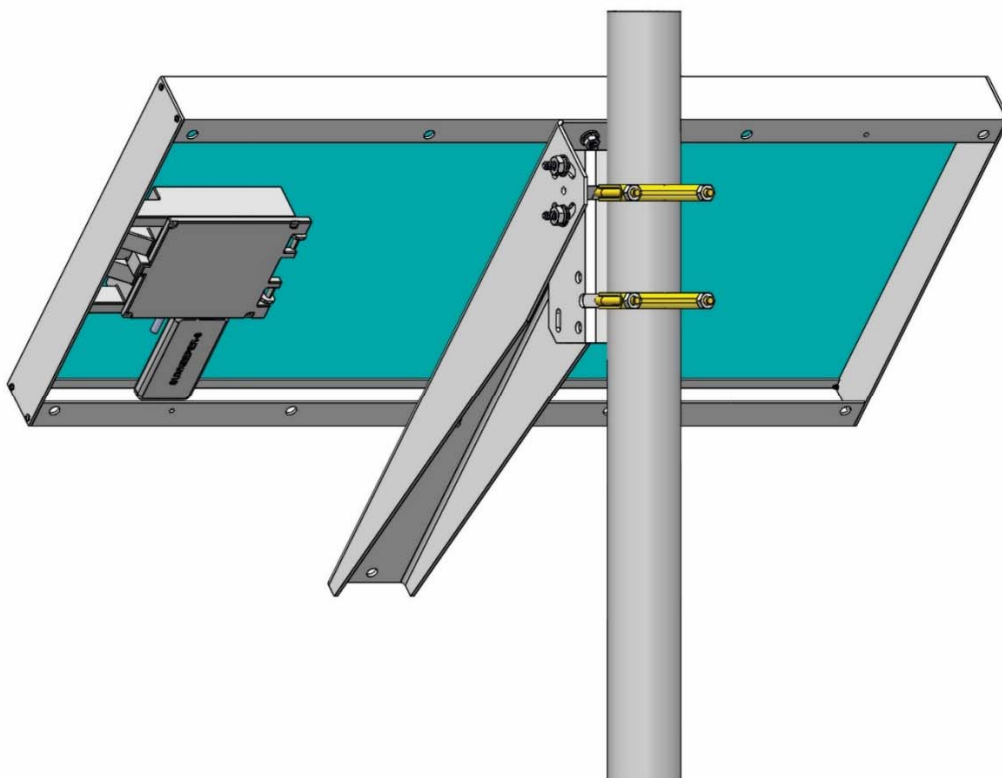

2.12 Adjusting the Optional Solar Panel

DANGER

EXPLOSION HAZARD: Ensure the area in which you perform this operation is non-hazardous. Performing this operation in a hazardous area could result in an explosion.

- Point the solar panel surface due south (in the northern hemisphere) or due north (in the southern hemisphere) at an angle determined by the latitude of the site. *Table 2-8* shows the angle (from horizontal) at which you should install the solar panel to maximize annual energy output. At most latitudes, you can improve performance by reducing the angle during the summer and increasing the angle during the winter. If no seasonal adjustments in panel direction are needed, then adjust the position for the worst-case December-January angle.
- Solar insolation is the amount of solar energy in hours received each day by an optimally tilted panel during the worst month of the year. An insolation rating of one hour means that the site, on average, would receive one hour of solar energy at the panel's rated power level (1000W/m² per day). This rating varies from less than one hour in northern Canada to more than six hours in the Sahara Desert.

Table 2-8: Solar Panel Tilt Angle

Latitude	Installation Angle
0 to 4°	10° from horizontal
5 to 20°	Add 5° to the local latitude
21 to 45°	Add 10° to the local latitude
46 to 65°	Add 15° to the local latitude
66 to 75°	80° from horizontal

To adjust the tilt angle on the 30W solar panel, loosen the four (4) nuts in the adjustable angle bracket and move the panel to the desired tilt angle. When in the proper position, torque the nuts to 108 in-lbs (12.2 N m) and apply Loctite® 222MS threadlocker sparingly to hex nut threads after torquing.

Figure 2-40: Adjusting the 30W Solar Panel Tilt Angle

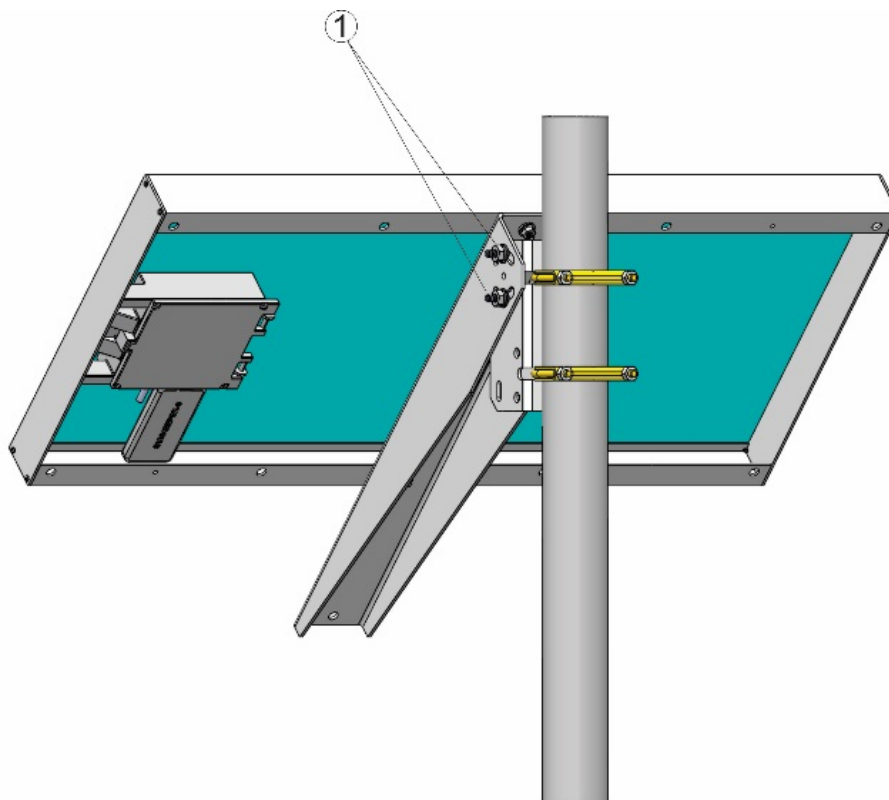

- 1 Tilt angle adjustment (2 of 4 shown)

The mounting brackets allow you to adjust the solar panel for maximum solar exposure.

2.13 Connecting Communication Ports

⚠ DANGER

EXPLOSION HAZARD: Ensure the area in which you perform this operation is non-hazardous. Performing this operation in a hazardous area could result in an explosion.

The communication ports allow you to connect to a PC or laptop running FBxConnect software or to other devices.

Open the enclosure door to access the terminal blocks for the three serial communication ports and the Ethernet port.

You route communication cables through the conduit fittings and connect the cables to the terminal blocks.

Note

The optional local serial port connector on the base of the enclosure is hard-wired to COM2.

2.13.1 Connecting to COM1

COM1 can be configured for RS-232, RS-422, or RS-485 communications.

When connecting COM1 to another device using **RS-232**, use a cable with configurations as shown in *Figure 2-41*:

Figure 2-41. Connecting a Device to COM1 Using RS-232

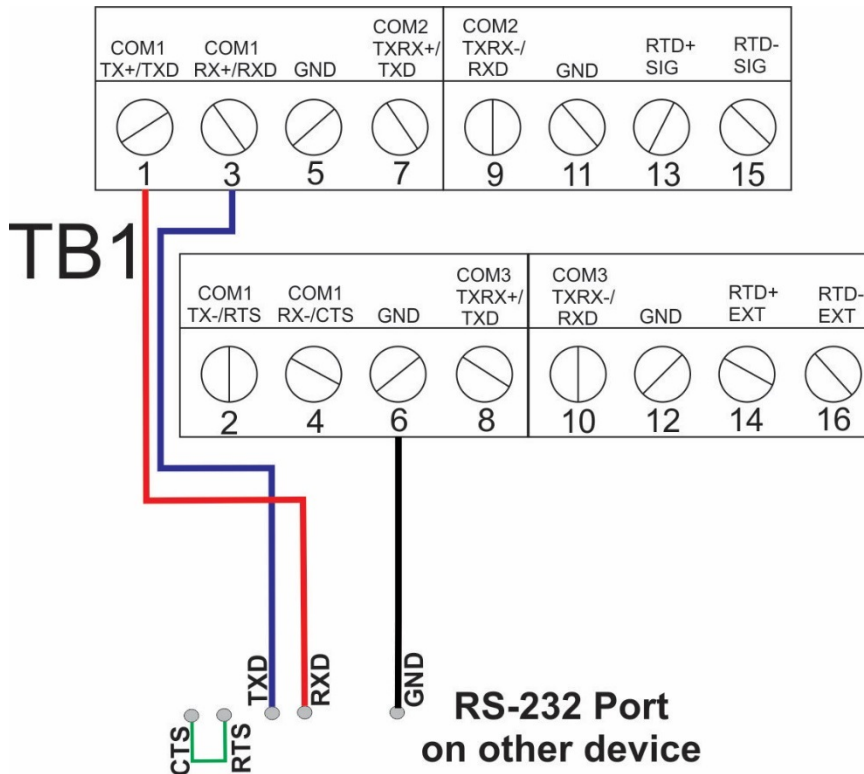

When connecting COM1 to another device using **RS-422**, use a cable with configurations as shown in *Figure 2-42*:

Figure 2-42. Connecting a Device to COM1 Using RS-422

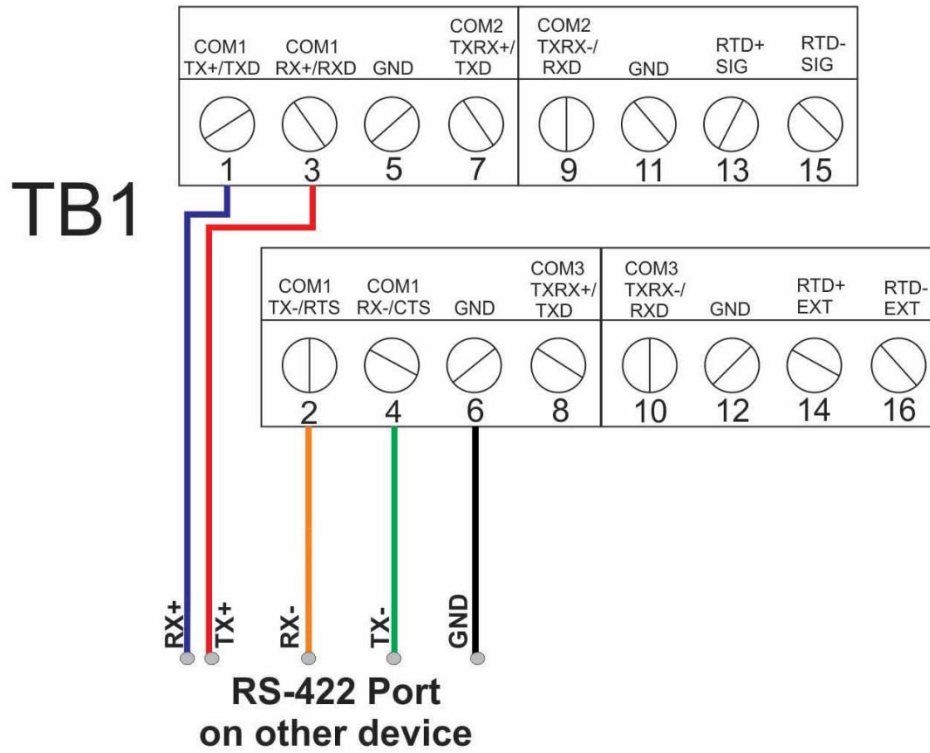

When connecting COM1 to another device using **RS-485**, use a cable with configurations as shown in *Figure 2-43*:

Figure 2-43. Connecting a Device to COM1 Using RS-485

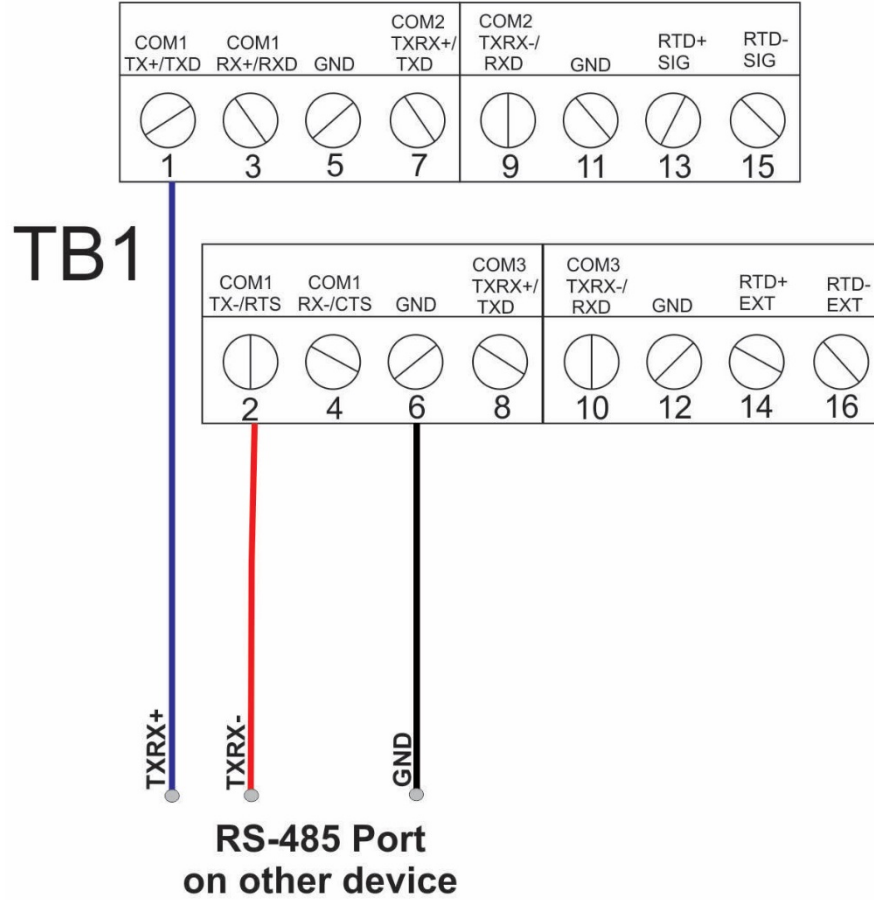

Regardless of the interface standard (RS-232, RS-422, or RS-485) you must use FBxConnect to configure the port for proper usage.

2.13.2 Connecting to COM2 and COM3

COM2 and COM3 operate identically. Each can be configured for either RS-232 or RS-485 communication.

When connecting COM2 or COM3 to an **RS-232** port on another device (a PC or another controller/flow computer) use a cable with configurations as shown in *Figure 2-44*:

Figure 2-44. Connecting a Device to COM2 or COM3 Using RS-232

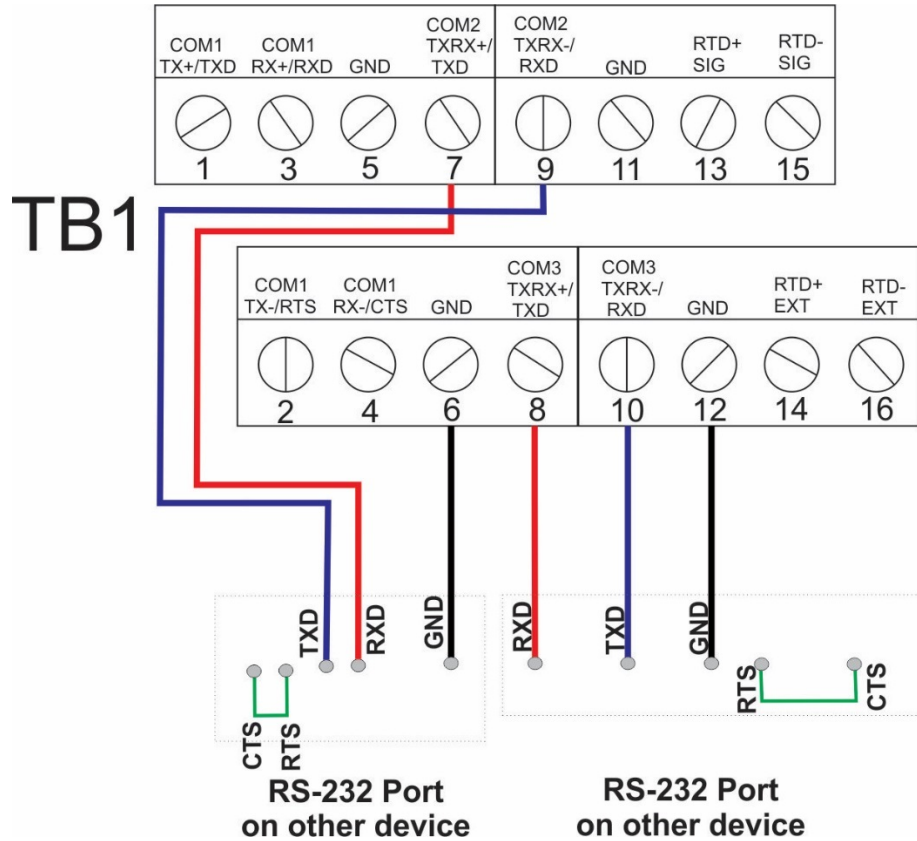

When connecting COM2 or COM3 to an **RS-485** port on another device (for example, a transmitter), use a cable with configurations as shown in *Figure 2-45*:

Figure 2-45. Connecting a Device to COM2 or COM3 Using RS-485

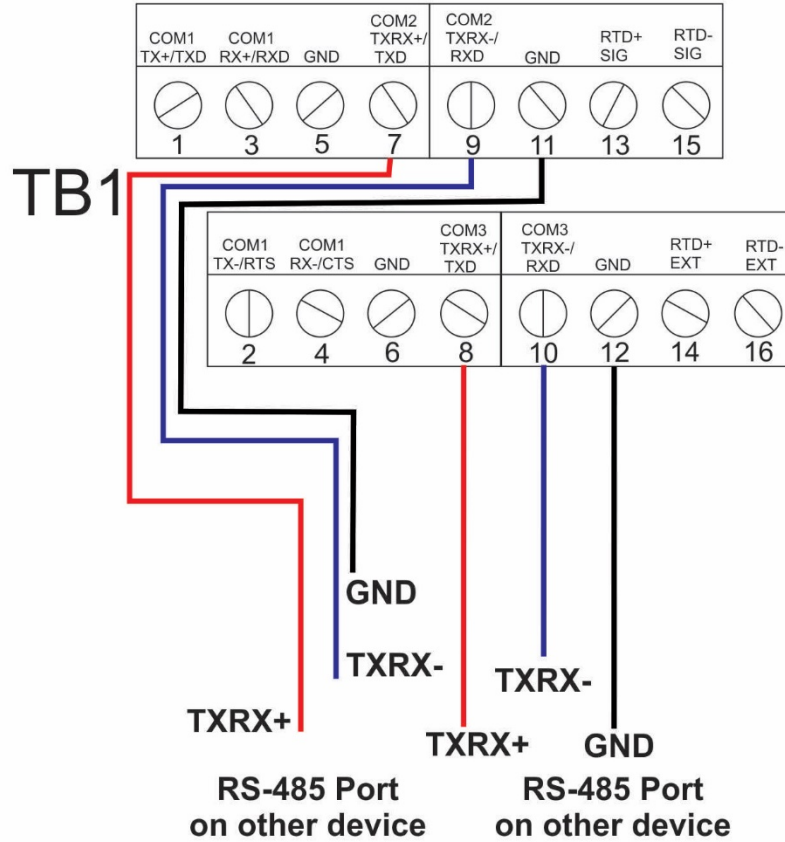

Regardless of the interface standard (RS-232 or RS-485), you must use FBxConnect to configure the port for proper usage.

2.13.3 Ethernet Port

The Ethernet port is a standard 8-pin 10/100Base-T RJ-45 modular connector located on the bottom right side of the CPU enclosure.

Figure 2-46. Location of Ethernet Port

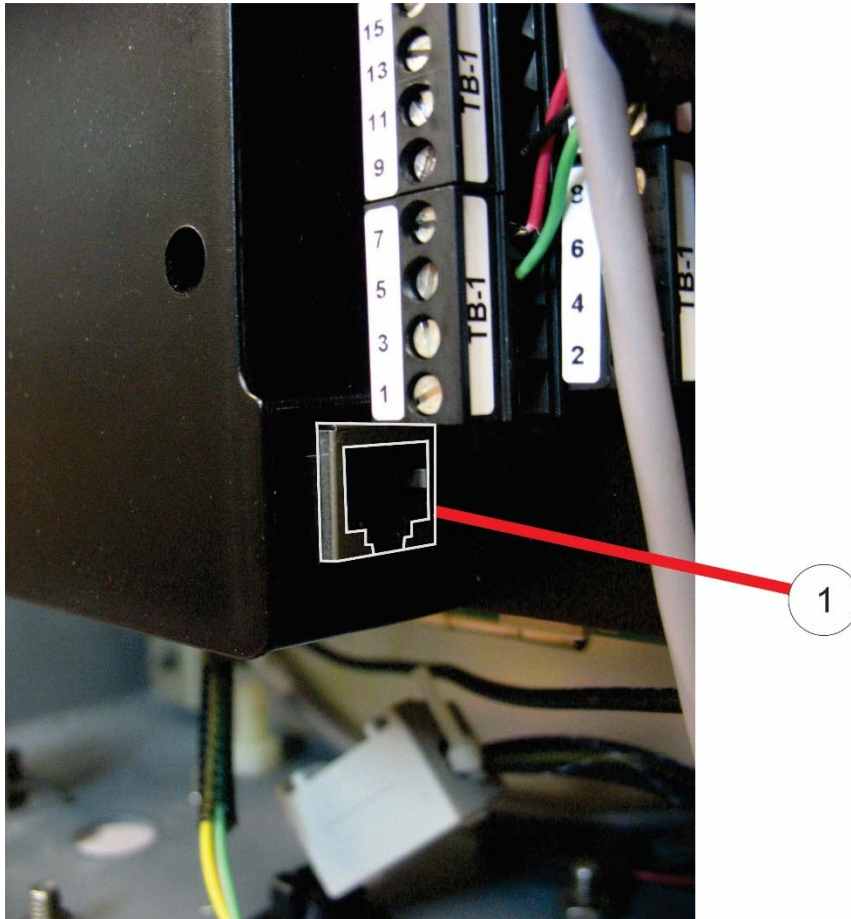

1 Ethernet Port

Connect to an Ethernet switch using the appropriate Category 5 shielded patch cable.

Note

- The default IP address for the Ethernet port is 192.168.1.10.
 - The default port is 20000.
-

Note

If you ordered Ethernet, the unit ships with Ethernet enabled. If you need to operate the device in lower power mode, you must disable Ethernet. Jumper J10 on the CPU module determines whether Ethernet is enabled or Ethernet is disabled (lower power mode). See the *CPU Enclosure and Electronics Field Replacement Guide* (D301803X012) for information on how to open the unit to gain access to the CPU module.

Figure 2-47. Ethernet Port jumper



- J10
- 1-2 Enable Ethernet
 - 2-3 Disable Ethernet (low power mode)

2.14 Security Intrusion Switch (OPTIONAL)

If ordered from the factory, the door contact wires to a momentary switch as shown using cable part number 399331-01-0.

Figure 2-48: Wiring the Security Intrusion Switch

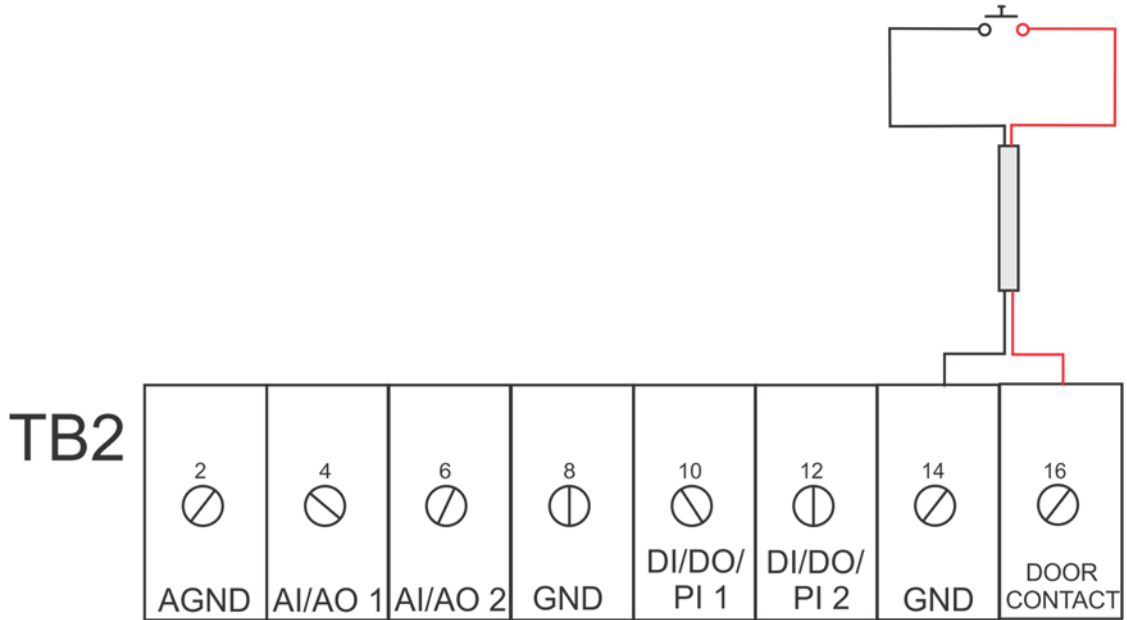

If you order the optional security intrusion switch, the flow computer ships from the factory with the door switch option enabled. To verify this, you can run FBxConnect software and click **Services > Board Info**. This allows you to view/modify the enable/disable setting for the **Door Switch**. **Note:** The door switch is always on Module_3.

Figure 2-49: Board Info Screen in FBxConnect

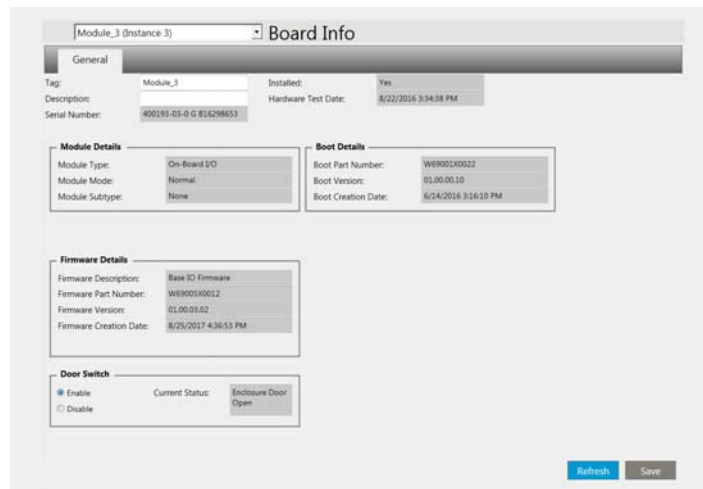

Section 3: I/O Configuration and Wiring

This section covers the following topics:

- Analog Inputs
- Analog Outputs
- Digital Inputs
- Digital Outputs
- Pulse Inputs
- Connecting the RTD/PRT
- Connecting a Rosemount 4088B Transmitter for Use in a Second Meter Run
- Wiring a Digital Output to the Optional Relay
- Radio Wiring

I/O in the FB2200 flow computer comes from the integrated multivariable sensor and RTD connector, the CPU board, as well as the optional mixed I/O board(s).

Note

When using a digital output to drive an inductive load (such as a relay coil), place a suppression diode across the load. This protects the DO from the reverse Electro-Motive Force (EMF) spike generated when the inductive load is switched off.

Figure 3-1: Base I/O (AI/AO1&2, DI/DO/PI 1 & 2)

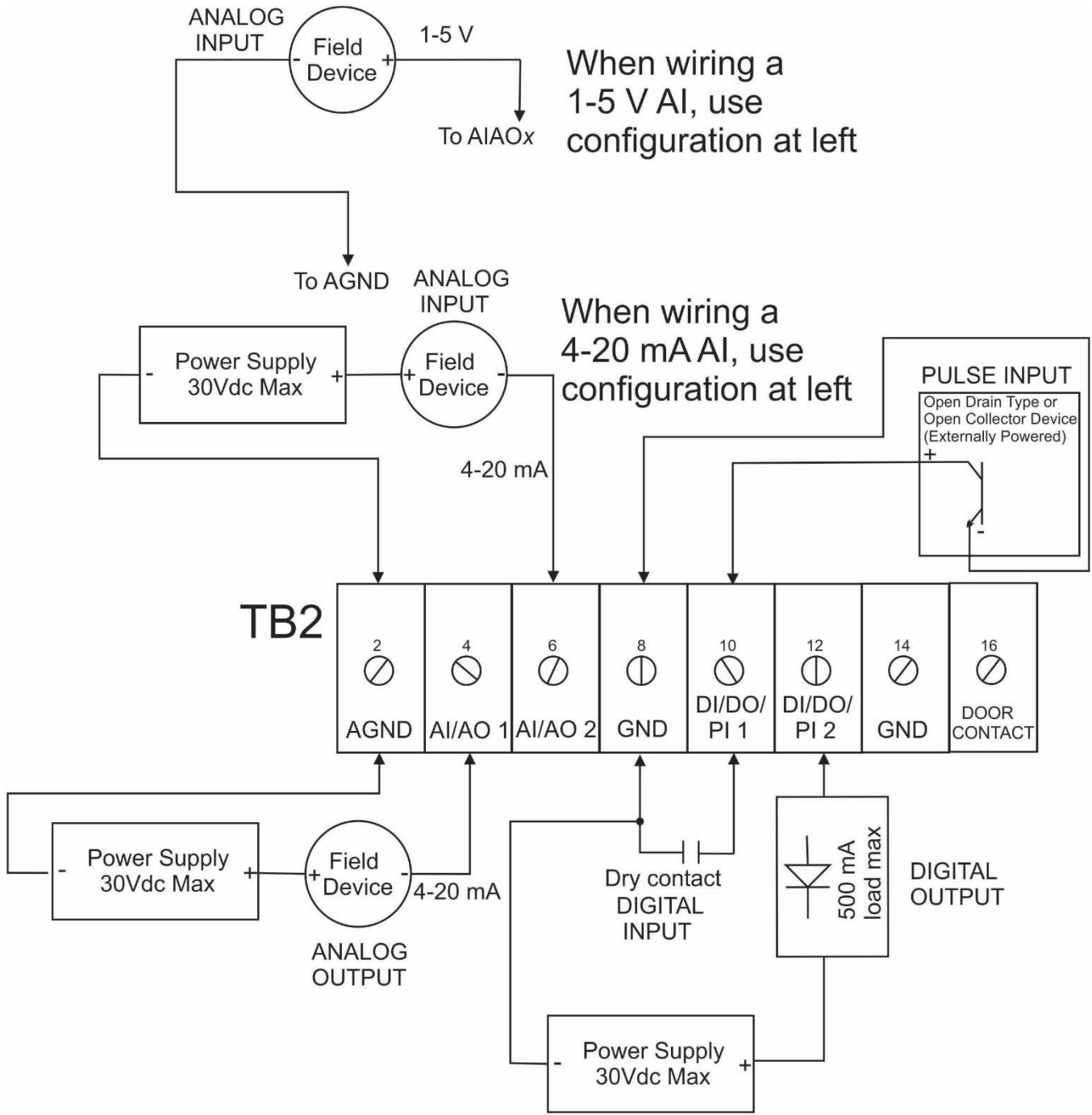
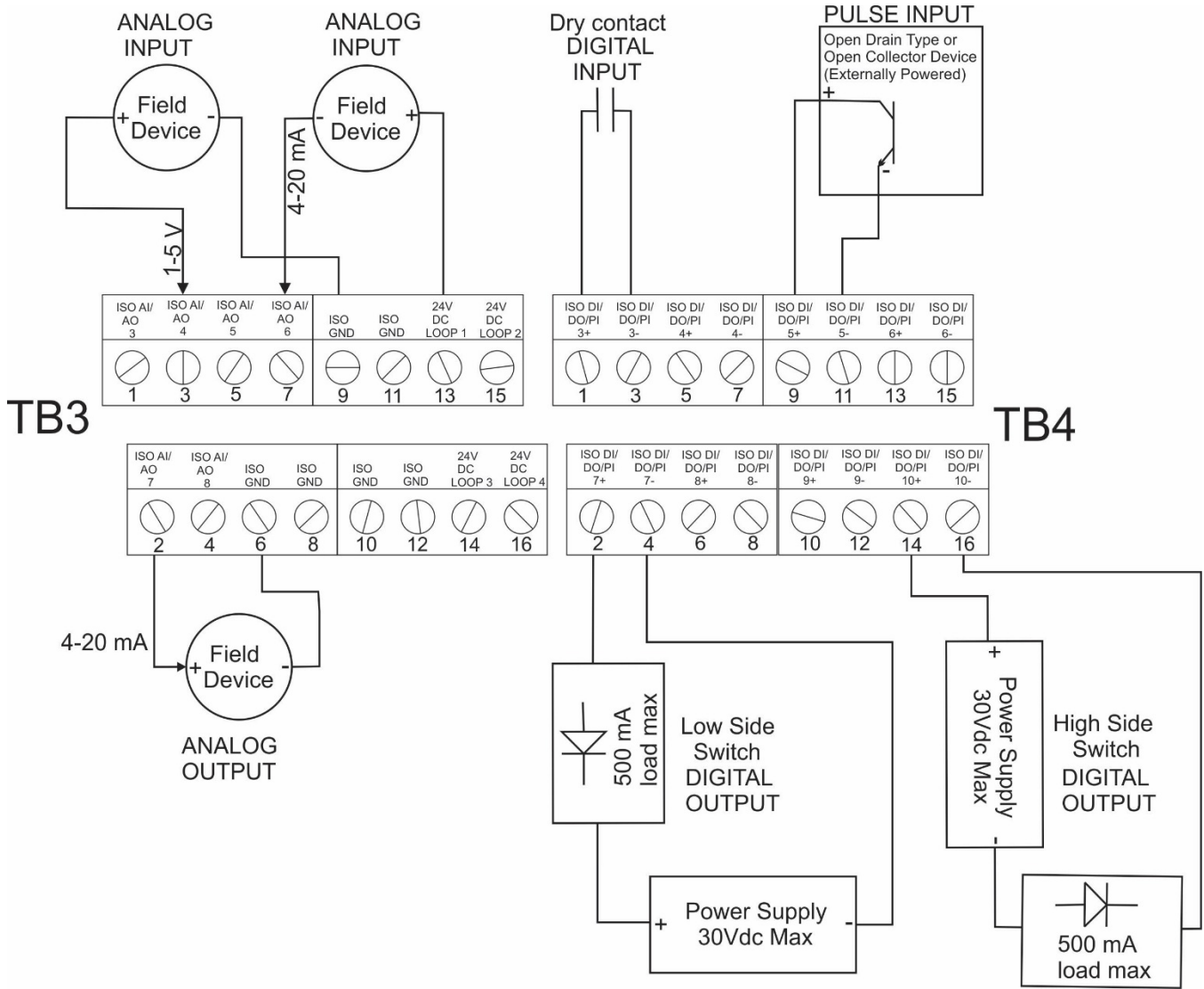

Figure 3-2: Wiring for 8-channel expansion I/O board and 6-channel expansion I/O board



3.1 Analog Inputs

The FB2200 flow computer includes two on-board channels you can individually configure as either analog inputs (AI) or analog outputs (AO). The optional 8-channel expansion I/O board includes 4 additional channels you can individually configure as AIs or AOs. In addition, if you purchased the optional 6-channel expansion I/O board, there are two additional channels you can individually configure as either AIs or AOs.

Note

No external resistor is required for a current (mA) device. You can apply a 250 ohm resistor using analog input configuration selections in FBxConnect.

When configured as analog inputs, the channels have the following characteristics:

Table 3-1: Analog Input Characteristics

Type	Number Supported	Characteristics
Analog Input (AI)	<p>0 to 8 as follows:</p> <ul style="list-style-type: none"> • 1 or 2 non-isolated channels on CPU board (AI/AO1 and AI/AO2) always present. You can configure one, both, or neither as AIs. • 1, 2, 3, or 4 additional isolated channels on optional 8-channel expansion I/O board (ISO AI/AO3, ISO AI/AO4, ISO AI/AO5, or ISO AI/AO6). If present you can configure any (or none) of the four channels as AIs. • 1 or 2 additional isolated channels on optional 6-channel expansion I/O board (ISO AI/AO7 and ISO AI/AO8). If present you can configure one, both, or neither as AIs. This board only allowed if 8-channel expansion I/O board is also present. 	<ul style="list-style-type: none"> • 4 to 20 mA range (@24Vdc), or 1 to 5Vdc • Over range for calibration purposes: 3.2 to 20.8 mA or 0.8 to 5.2 Vdc • AI1 and AI2 require external power when in current mode ONLY • Factory calibrated (re-calibration is unnecessary for at least 3 years) • Signal conditioning • When you configure a channel as an AI it cannot be used as an AO

3.1.1 AI Wiring

The diagrams below show how to wire the analog input.

Figure 3-3: Analog Input (AI) Wiring (Base I/O – AI/AO1 & AI/AO2 only)

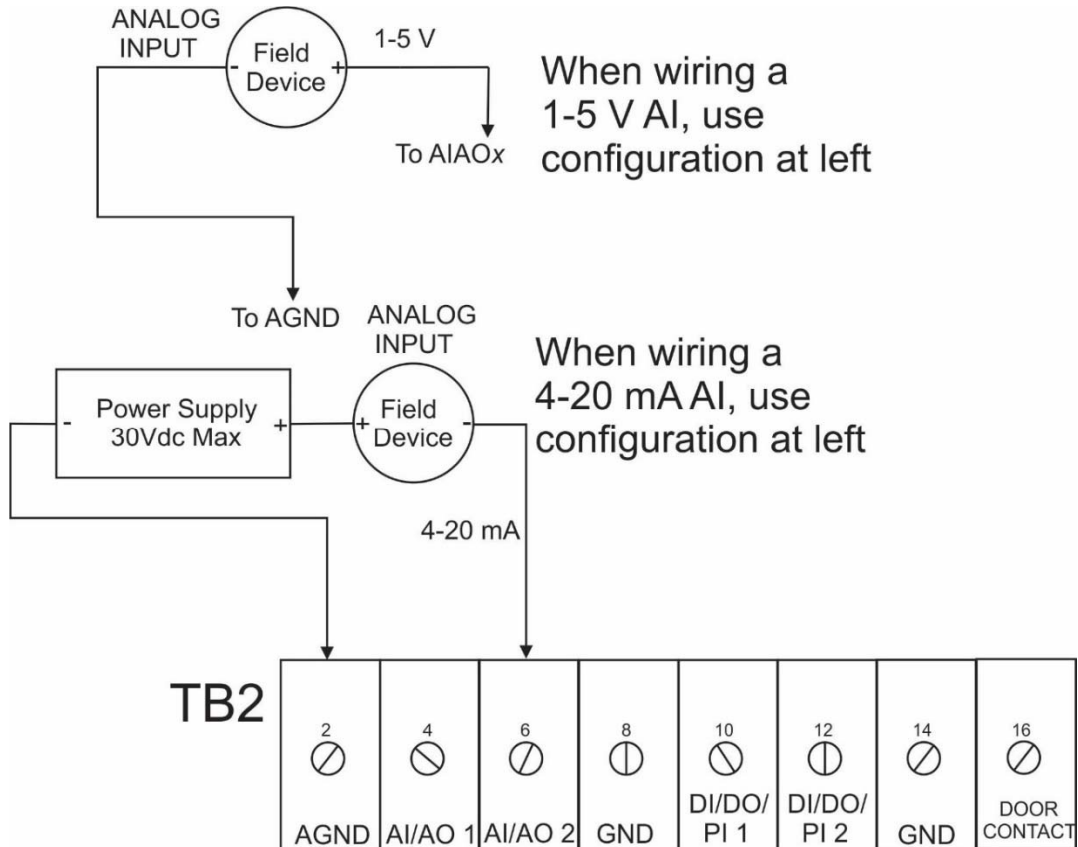
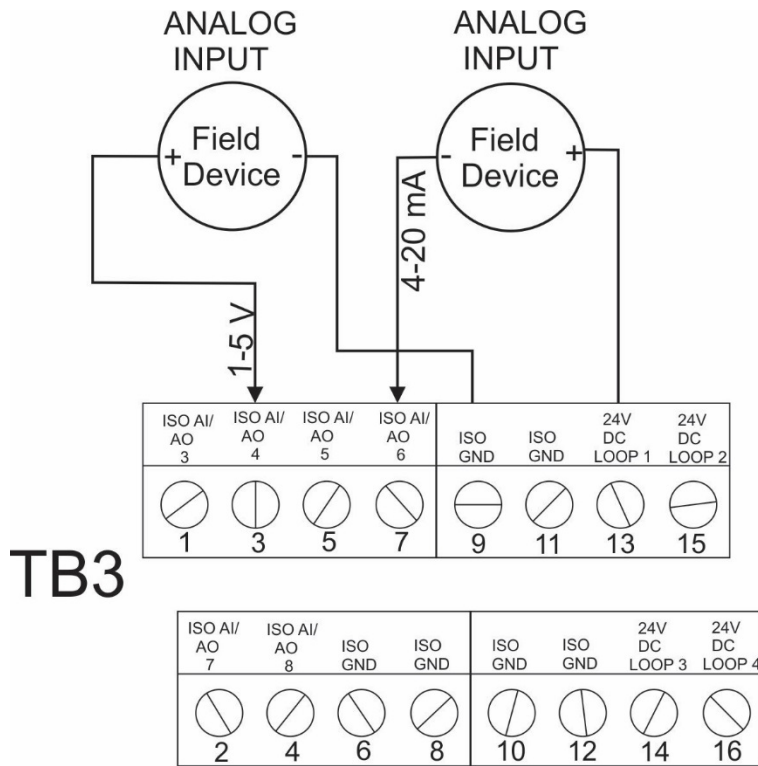

Figure 3-4: Analog Input (AI) Wiring – (Optional 8-channel expansion I/O board [ISO AI/AO3,4,5,6] and optional 6-channel expansion I/O board [ISO AI/AO7, 8])



3.2 Analog Outputs

The FB2200 flow computer includes two on-board channels you can individually configure as either analog outputs (AO) or analog inputs (AI). The optional 8-channel expansion I/O board includes 4 additional channels you can individually configure as AOs or AIs. In addition, if you purchased the optional 6-channel expansion I/O board, there are two additional channels you can individually configure as either AOs or AIs.

When configured as analog outputs, the channels have the following characteristics:

Table 3-2: Analog Output Characteristics

Type	Number Supported	Characteristics
Analog Output (AO)	<p>0 to 8 as follows:</p> <ul style="list-style-type: none"> 1 or 2 non-isolated channels on CPU board (AI/AO1 and AI/AO2) always present. You can configure one, both, or neither as AOs. Note: If you configure both as AOs we recommend you provide isolation to avoid ground loops which could affect readings. 1, 2, 3, or 4 additional isolated channels on optional 8-channel expansion I/O board (ISO AI/AO3, ISO AI/AO4, ISO AI/AO5, or ISO AI/AO6). If present you can configure any (or none) of the four channels as AOs. 1 or 2 additional isolated channels on optional 6-channel expansion I/O board (ISO AI/AO7 and ISO AI/AO8). If present you can configure one, both, or neither as AOs). This board only allowed if 8-channel expansion I/O board is also present. 	<ul style="list-style-type: none"> 4 to 20 mA range (@24Vdc) Externally powered field device (AI/AO1 and AI/AO2) 24V loop supply powers AO (ISO AI/AO3 through ISO AI/AO8) AO sinks current to system ground Factory calibrated (re-calibration is unnecessary for at least 3 years) You can configure a fail state so that on power up or if the CPU fails the output drives to 0 μA When a channel is configured as an AO it cannot be used as an AI

3.2.1 AO Wiring

The diagrams below show how to wire the analog output.

Figure 3-5: Analog Output (AO) Wiring – (Base I/O – AI/AO1 & AI/AO2)

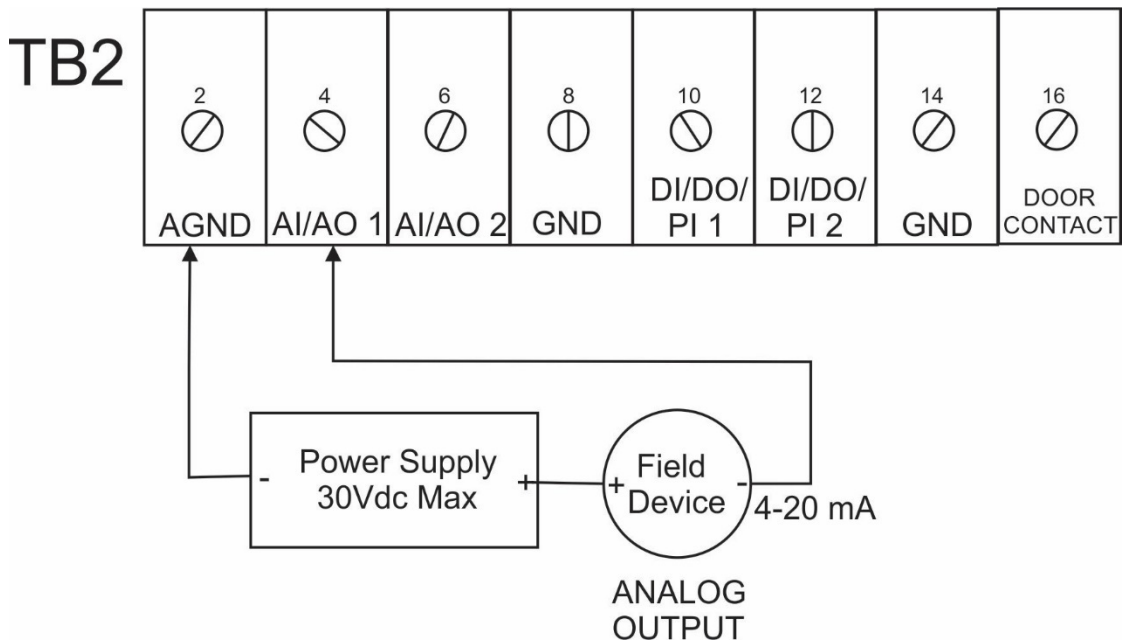
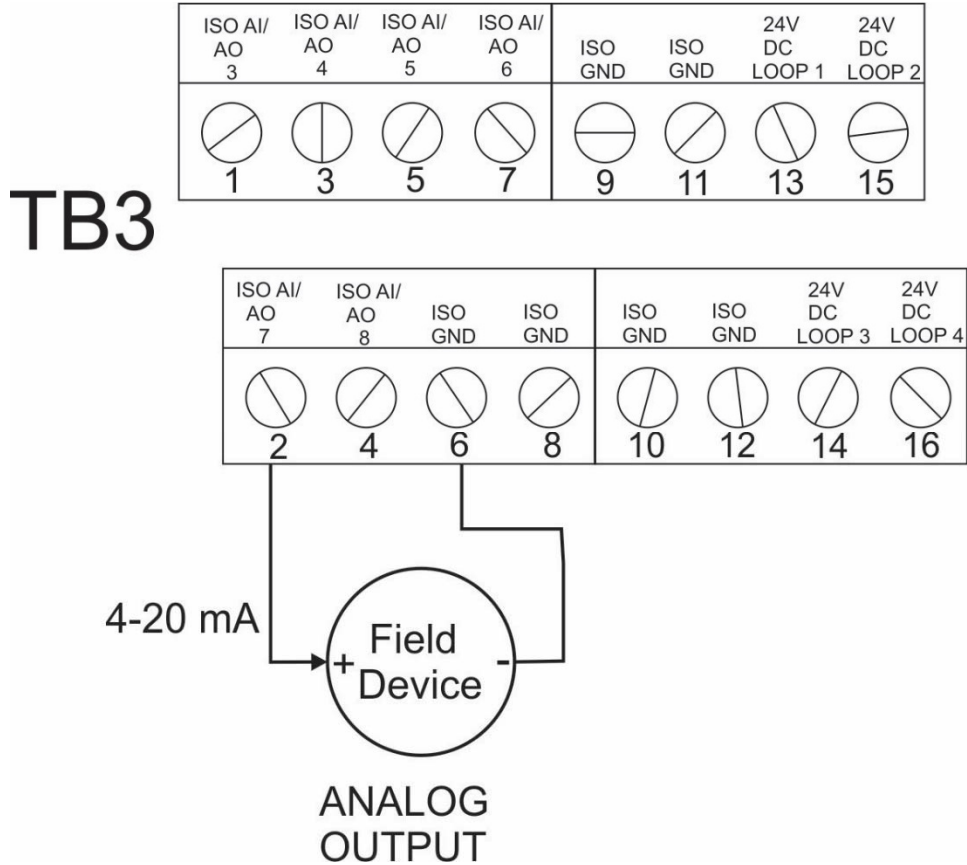

Figure 3-6: Analog Output (AO) Wiring – (Optional 8-channel expansion I/O board [ISO AI/AO3,4,5,6] and optional 6-channel expansion I/O board [ISO AI/AO7, 8])



3.3 Digital Inputs

Depending upon how you ordered it, the FB2200 flow computer includes two, six, or ten channels you can individually configure as digital inputs (DI), digital outputs (DO), or pulse inputs (PI).

When configured as digital inputs, the channels have the following characteristics:

Table 3-3: Digital input Characteristics

Type	Number Supported	Characteristics
Digital Input (DI)	<p>0 to 10 as follows:</p> <ul style="list-style-type: none"> • 1 or 2 non-isolated channels on CPU board (DI/DO/PI1 and DI/DO/PI2). Two always present; you can configure one, both, or neither as DIs. • 1 to 4 additional isolated channels on optional 8-channel expansion I/O board (ISO DI/DO/PI3 to ISO DI/DO/PI6). If present you can configure one, two, three, four or none as DIs. • 1 to 4 additional isolated channels on optional 6-channel expansion I/O board (ISO DI/DO/PI7 to ISO DI/DO/PI10). If present you can configure one, two, three, four or none as DIs. This board only allowed if 8-channel expansion I/O board is also present. 	<ul style="list-style-type: none"> • Circuit protection • 30ms input filtering • Maximum input frequency of 10 Hz • Selectable current source of 66 μA or 2 mA • Either externally driven or internally driven and pulled to ground by dry contact closures or open collector devices • When a channel is configured as a DI it cannot be used as a DO or PI channel

3.3.1 DI Wiring

The diagrams below show how to wire the digital input.

Figure 3-7: Digital Input (DI) Wiring – (Base I/O – DI/DO/PI1 & DI/DO/PI2)

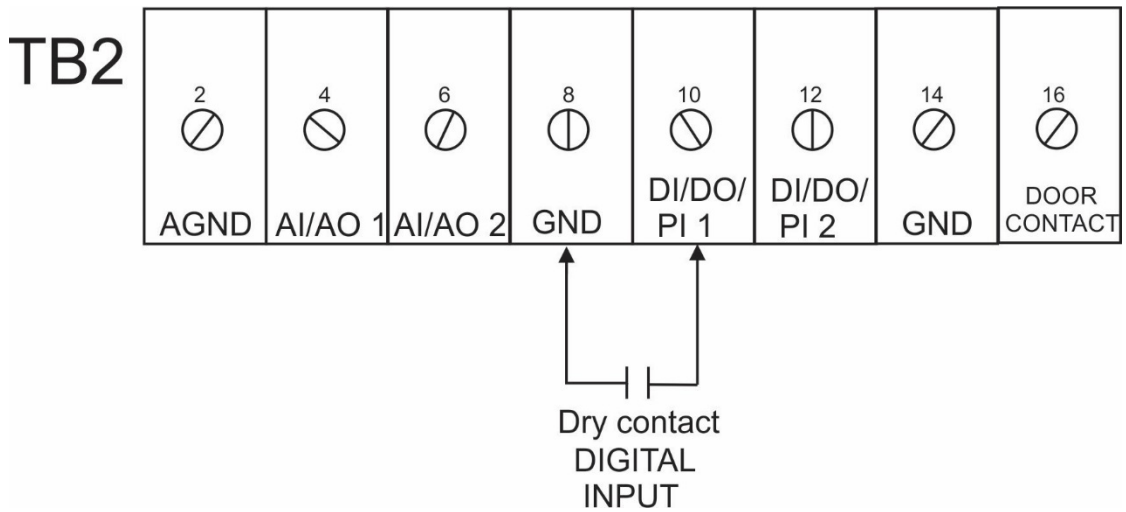
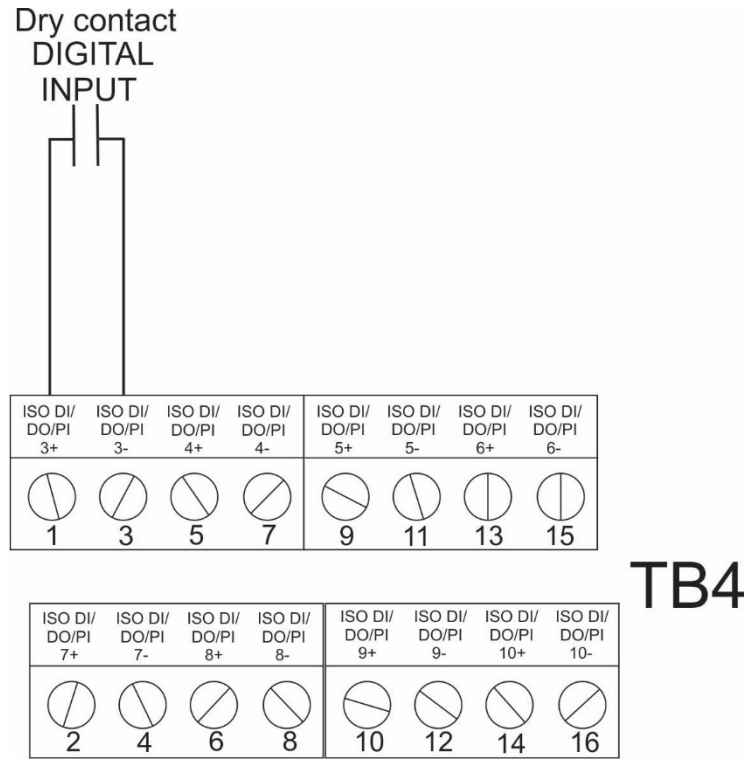

Figure 3-8: Digital Input (DI) Wiring – (8-Channel Expansion I/OB Board [ISO DI/DO/PI3,4,5,6] and 6-Channel Expansion I/O Board [ISO DI/DO/PI 7,8,9,10])



3.4 Digital Outputs

Depending upon how you ordered it, the FB2200 flow computer includes two, six, or ten channels you can configure as digital outputs (DO), digital inputs (DI) or pulse inputs (PI).

Note

When using a digital output to drive an inductive load (such as a relay coil), place a suppression diode across the load. This protects the DO from the reverse Electro-Motive Force (EMF) spike generated when the inductive load is switched off.

When configured as digital outputs, the channels have the following characteristics:

Table 3-4: Digital Output Characteristics

Type	Number Supported	Characteristics
Digital Output (DO)	<p>0 to 10 as follows:</p> <ul style="list-style-type: none"> 1 or 2 non-isolated channels on CPU board (DI/DO/PI1 and DI/DO/PI2). Two always present; you can configure one, both, or neither as DOs. 1 to 4 additional isolated channels on optional 8-channel expansion I/O board (ISO 	<ul style="list-style-type: none"> DO is a low side switch that sinks current to ground Current rating of 500 mA Maximum operating frequency of 50 Hz Pulse off/on time can be configurable with a 31 ms minimum on time and a 31 ms minimum off time

	<p>DI/DO/PI3 to ISO DI/DO/PI6). If present you can configure one, two, three, four or none as DOs.</p> <ul style="list-style-type: none"> • 1 to 4 additional isolated channels on optional 6-channel expansion I/O board (ISO DI/DO/PI7 to ISO DI/DO/PI10). If present you can configure one, two, three, four or none as DOs. This board only allowed if 8-channel expansion I/O board is also present. 	<ul style="list-style-type: none"> • Can be configured in software with an output state for initial power-up and in the case of a CPU failure • Software configurable failure mode of fail open, fail closed, or hold last state • When a channel is configured as a DO it cannot be used as a DI or PI channel
--	--	--

Note

Digital outputs are rated to 500mA maximum. In a small number of applications, however, the load on the DO could have an effect on the uncertainty of the analog inputs and outputs. The typical increase in uncertainty is around 0.05% and only occurs when all of the following are true:

- Either of the two analog channels in the base I/O is used as an AI (in voltage mode) or as an AO and
- Either of the two digital channels in the base I/O is used as a DO and
- The total current load on these two DOs is greater than 300mA
- Analog inputs in current mode and the I/O channels in the expansion I/O boards are not affected.

3.4.1 DO Wiring

The diagrams below show how to wire the digital output.

Figure 3-9: Digital Output (DO) Wiring – (Base I/O – DI/DO/PI1 & DI/DO/PI2)

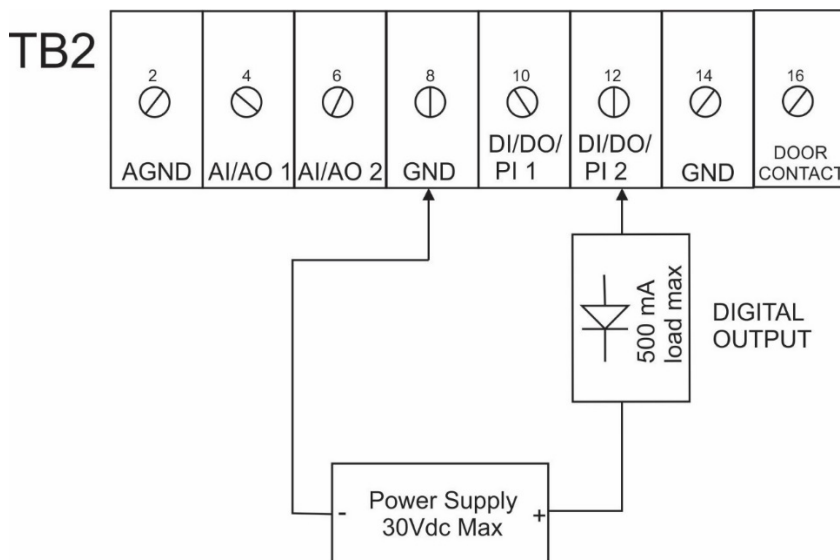
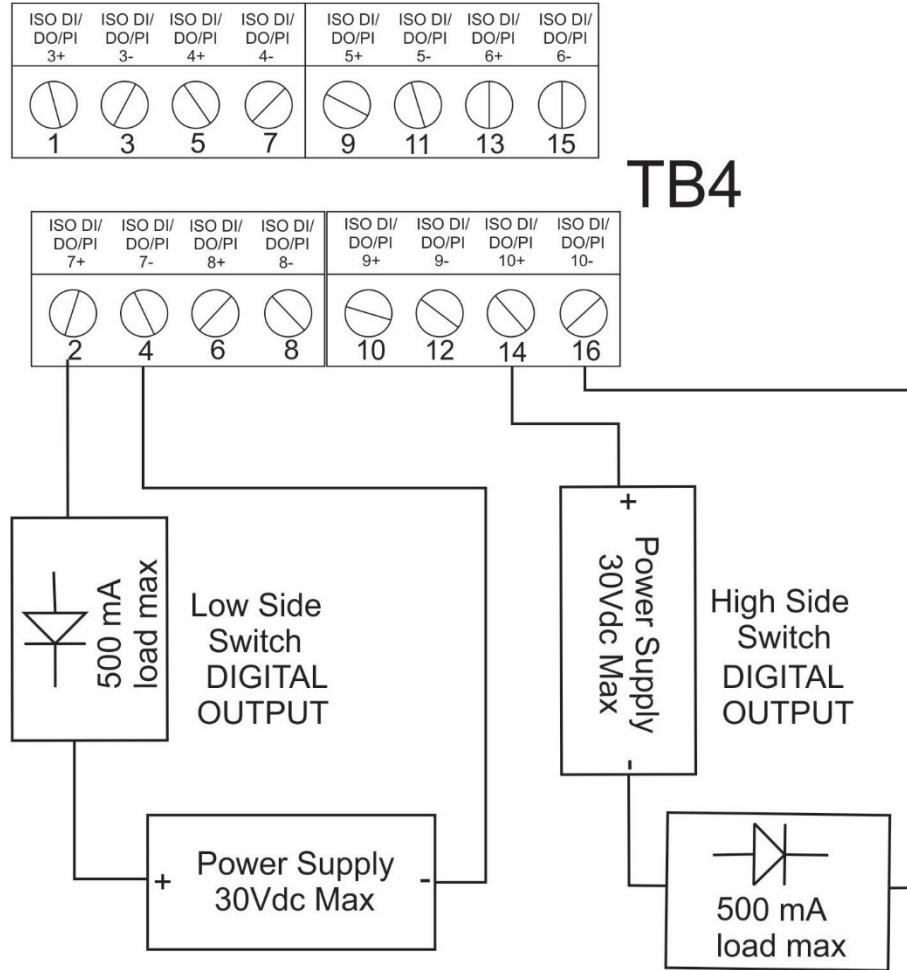

Figure 3-10: Digital Output (DO) Wiring – (Optional 8-channel expansion I/O board [ISO DI/DO/PI3,4,5,6] and optional 6-channel expansion I/O board [ISO DI/DO/PI7,8,9,10])



3.5 Pulse Inputs

Depending upon how you ordered it, the FB2200 flow computer includes two, six, or ten channels you can individually configure as either pulse inputs (PI), digital inputs (DI), or digital outputs (DO).

When configured as pulse inputs, the PI channels have the following characteristics:

Table 3-5: Pulse Input Characteristics

Type	Number Supported	Characteristics
Pulse Input (PI)	<p>0 to 10 as follows:</p> <ul style="list-style-type: none"> • 1 or 2 non-isolated channels on CPU board (DI/DO/PI1 and DI/DO/PI2). Two always present; you can configure one, both, or neither as PIs. • 1 to 4 additional isolated channels on optional 8-channel expansion I/O board (ISO DI/DO/PI3 to ISO DI/DO/PI6). If present you can configure one, two, three, four or none as PIs. • 1 to 4 additional isolated channels on optional 6-channel expansion I/O board (ISO DI/DO/PI7 to ISO DI/DO/PI10). If present you can configure one, two, three, four or none as PIs. This board only allowed if 8-channel expansion I/O board is also present. 	<ul style="list-style-type: none"> • Supports dry contacts and open collector outputs connected to ground and voltage inputs • Supports single pulse for volume or mass • Input filtering selectable at 30 μs or 1 ms • Frequency range from 0 to 10.5 KHz • Maximum input frequency for the 1 ms filter is 300 Hz • When a channel is configured as a PI it cannot be used as a DI or DO channel • ON when greater than 3.0V; OFF when less than 2.0V.

3.5.1 PI Wiring

The diagrams below show how to wire the pulse input.

Figure 3-11: Pulse Input (PI) Wiring - (Base I/O – DI/DO/PI1 & DI/DO/PI2)

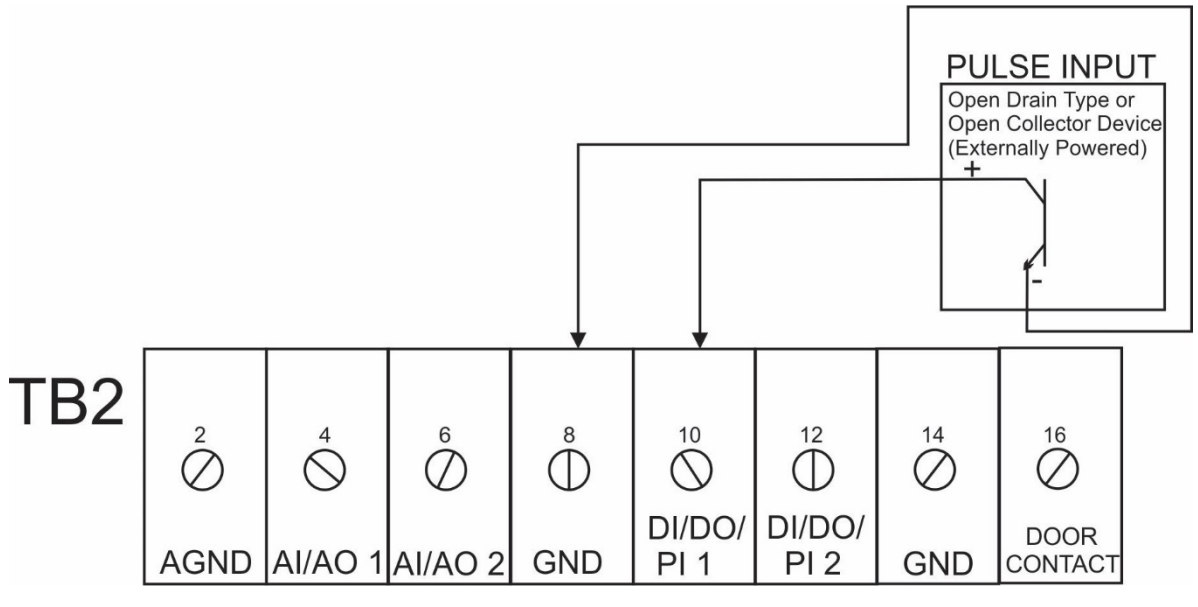
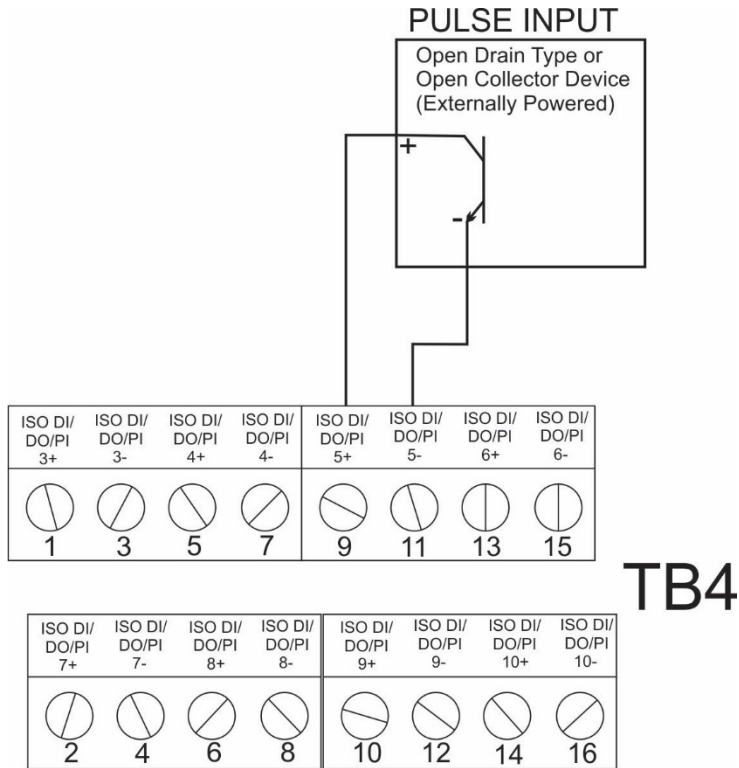

Figure 3-12: Pulse Input (PI) Wiring – (8-Channel Expansion I/O Board [ISO DI/DO/PI3,4,5,6] and 6-Channel Expansion I/O Board[ISO DI/DO/PI7,8])



3.6 Connecting the RTD/PRT

⚠ DANGER

EXPLOSION HAZARD: Ensure the area in which you perform this operation is non-hazardous. Performing this operation in a hazardous area could result in an explosion.

RTD connections reside on the terminal blocks inside the enclosure. The flow computer supports 2-wire, 3-wire, and 4-wire operation. Route the RTD cable through the conduit fittings and connect them on the terminal blocks (as shown on [Figure 3-13](#), [Figure 3-14](#) and [Figure 3-15](#)).

Note

The device defaults to the 4-wire RTD configuration; you can change this setting in FBxConnect.

Figure 3-13: Wiring for 2-Wire

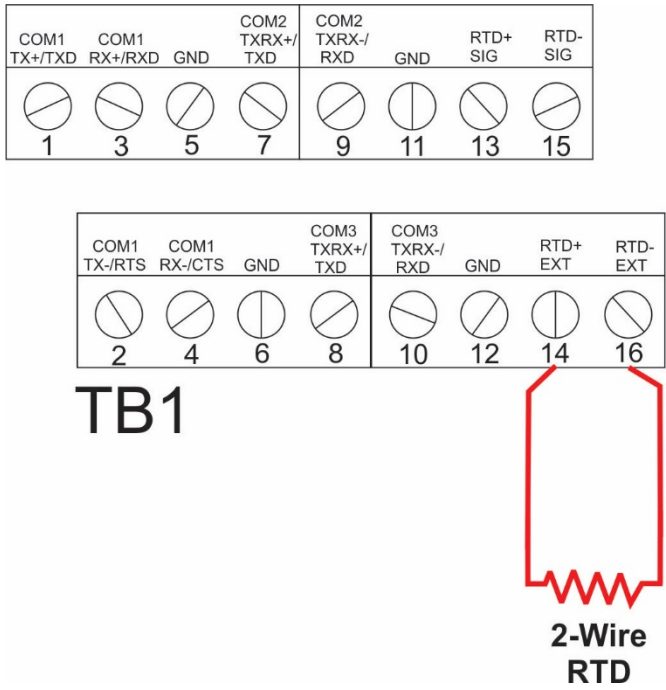

Figure 3-14: Wiring for 3-Wire

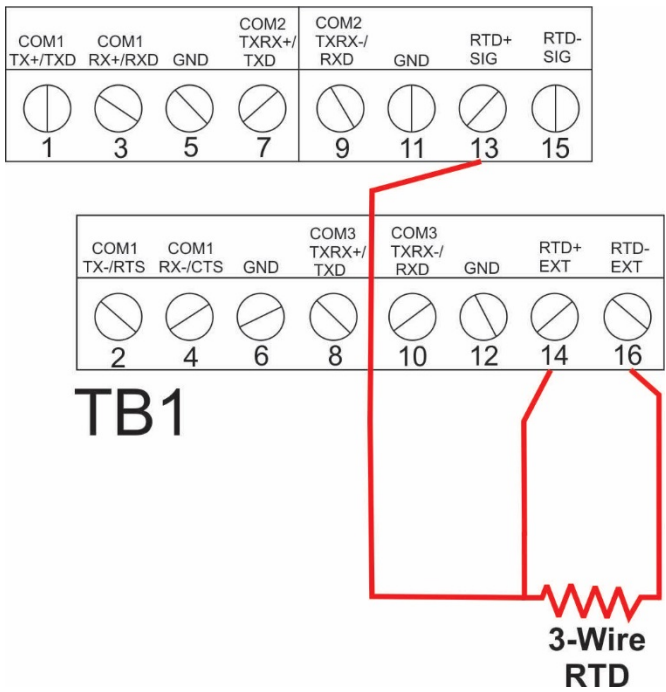
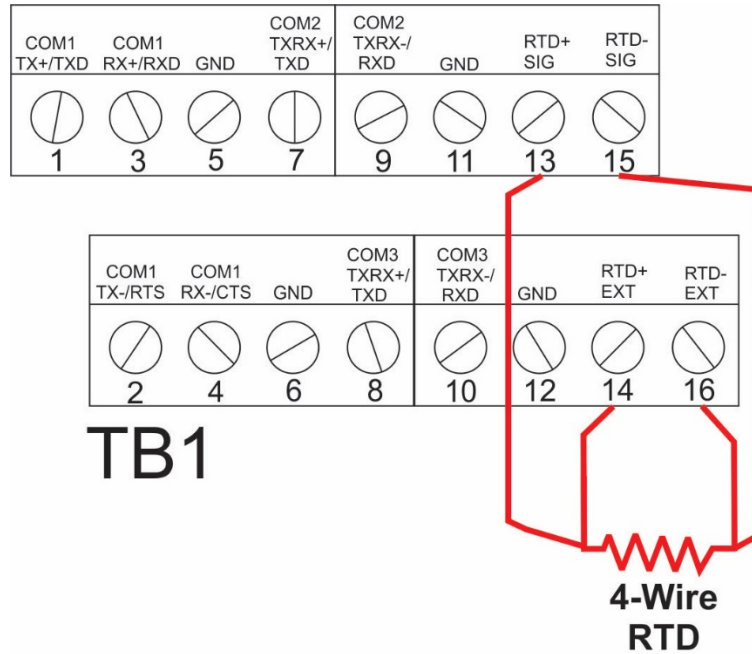

Figure 3-15: Wiring for 4-Wire



3.7 Connecting a Rosemount 4088B Transmitter For Use in a Second Meter Run

Data for the second run comes from an external transmitter such as the Rosemount 4088B.

See the *Rosemount™ 4088 Multivariable™ Transmitter Reference Manual (00809-0100-488, Rev. CB, Feb. 2017)* for details on installing the 4088B.

1. Using twisted pair wire, connect the RS-485 terminals for COM3 to the RS-485 terminals on the 4088B as shown in the graphic.

Figure 3-16: Connecting a 4088B Transmitter for a Second Meter Run

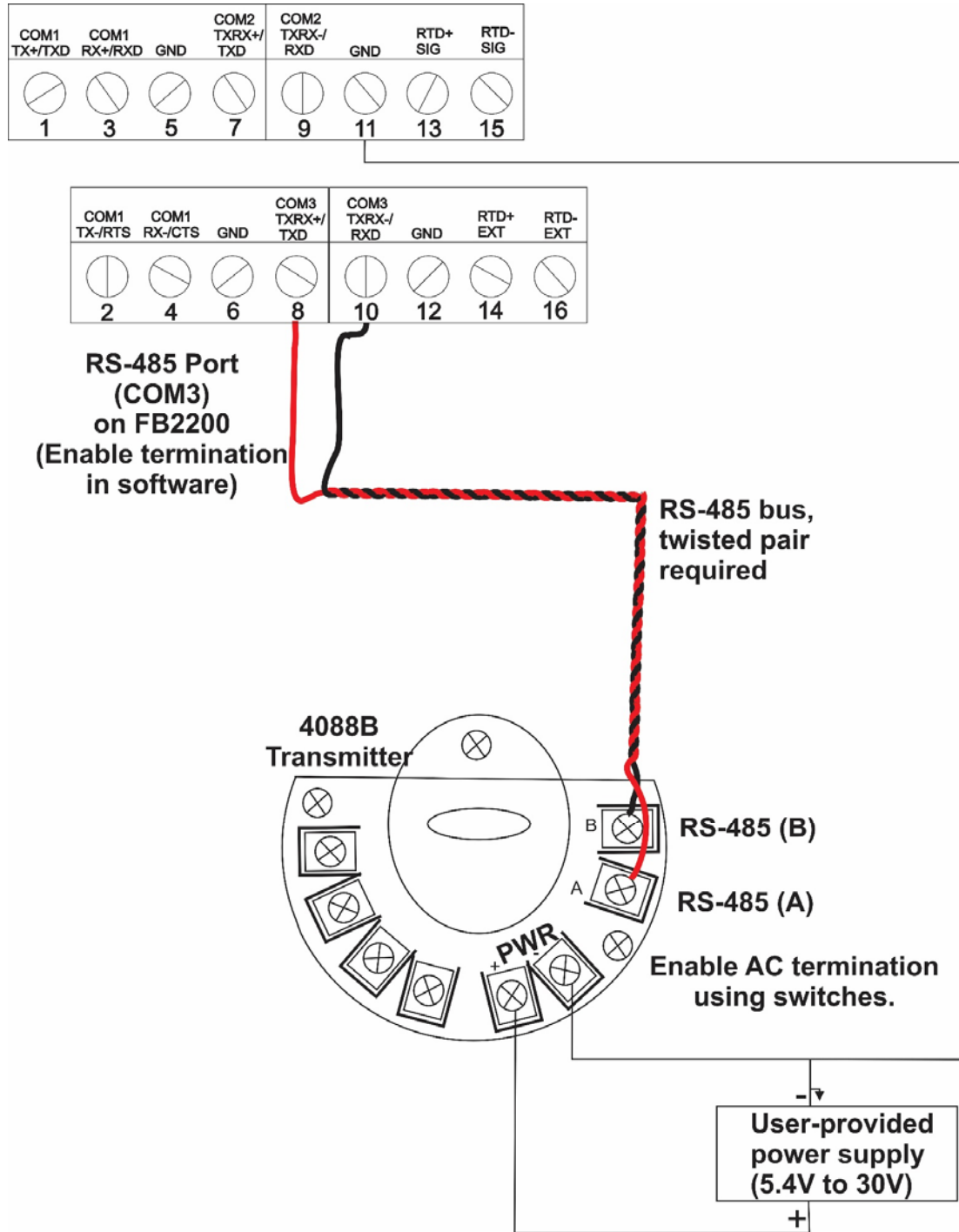

- Set switches on the 4088B for bus termination, or use a 120 ohm resistor.
- Use FBxConnect software to configure COM3 for RS-485. In particular, enable termination for the port.

3.8 Wiring a Digital Output to the Optional Relay

The flow computer supports two optional electro-mechanical relays for switching on/off external circuits or devices. If you order this option, the relays ship from the factory mounted to the top of the battery compartment inside the flow computer enclosure.

You can wire a relay to an isolated DO (*Figure 3-17*). You must also use the isolated GND and provide 24V to power the relay. To attach a wire, insert it into the connector and tighten the adjacent screw to secure it. The NO and COM wires go to your external circuit or device.

Figure 3-17: Relay Wired to Isolated DO

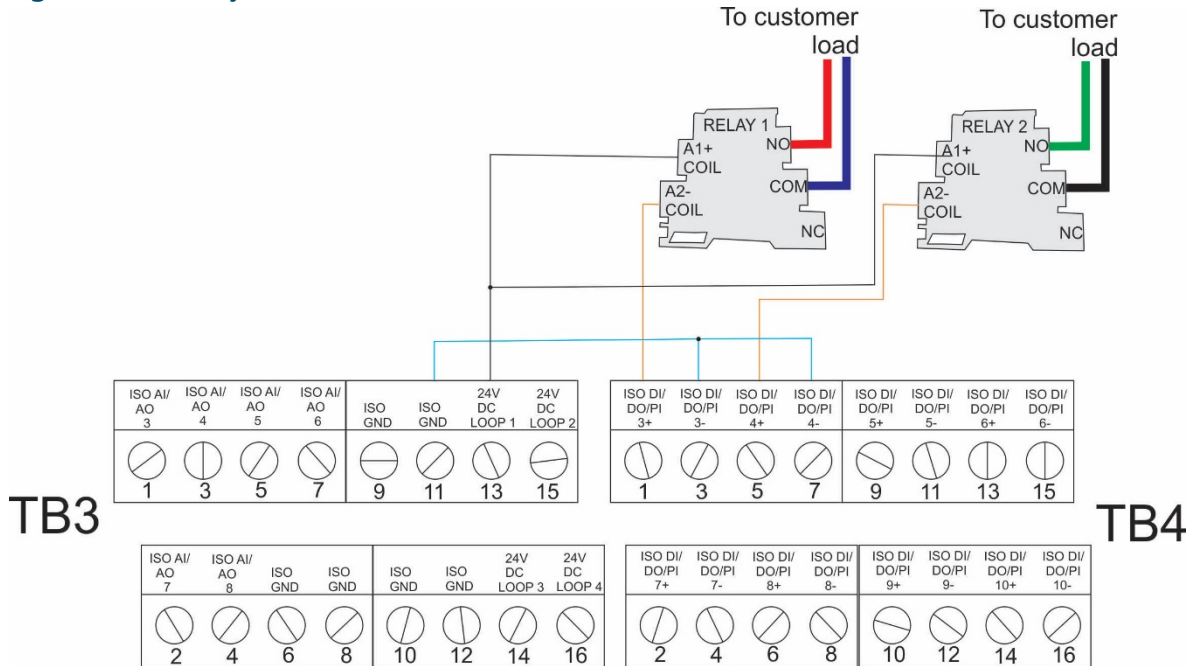

Alternatively, you can wire a relay to a non-isolated DO (*Figure 3-18*). In that case, you must use the non-isolated GND and provide 24V to power the relay. To attach a wire, insert it into the connector and tighten the adjacent screw to secure it. The NO and COM wires go to your external circuit or device.

Figure 3-18: Relay Wired to Non-Isolated DO

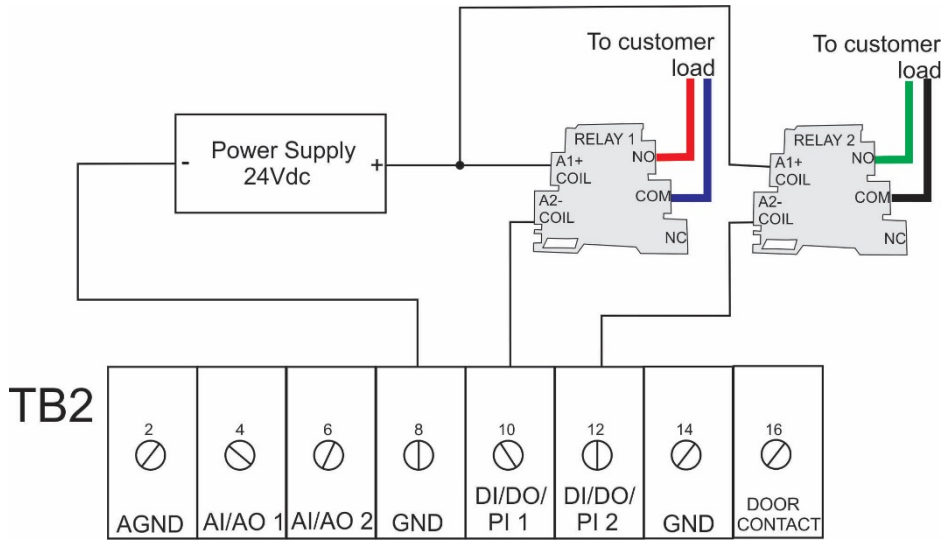

3.9 Radio Wiring

To power a radio, you wire it to the RADIO PWR and RADIO RTN terminals. These follow whatever the power supply provides the flow computer at the DCIN+ terminal.

Rating: DCIN @ 1A.

You must enable radio power in FBxConnect. Click **Configure > System** to bring up the System screen from which you enable radio power.

Figure 3-19: Radio Wiring

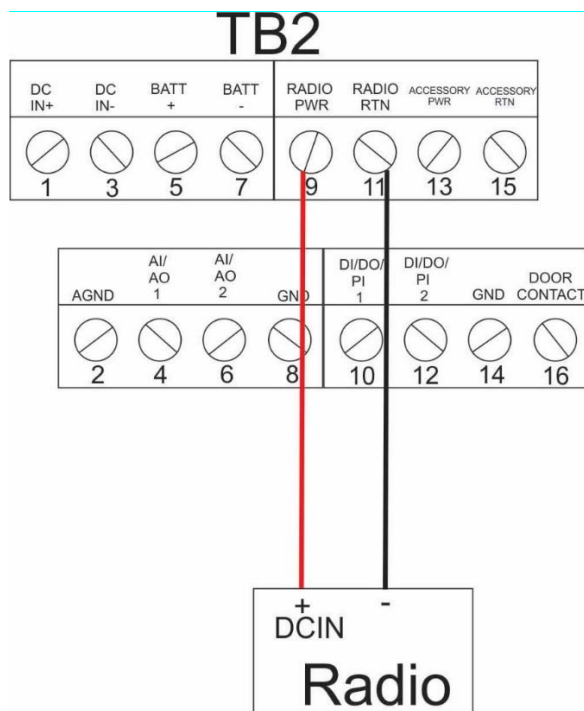

Section 4: Operation

This section covers the following topics:

- Powering Up/Powering Down the Device
- Establishing Communications
- Communicating using the HMI Module

This section describes day-to-day operation of the flow computer including how to turn it on and off, and how to communicate with it.

4.1 Powering Up/Powering Down the Device

DANGER

Do not attempt to connect or disconnect power from the unit in a hazardous area. Ensure the area is non-hazardous. Failure to do so could result in an explosion.

1. Open the enclosure door.
2. Terminal block TB2 (pins 1,3,5,7) includes connections for DC power (DCIN+, DCIN-) and battery/ solar power (BATT+, BATT-). The internal battery (which is also used with solar power) has its own internal connectors.
 - Plug in TB2 (pins 1,3,5,7) to activate DC or battery/solar power. If your device uses an internal battery and it is not connected, connect it as discussed in *Connecting the Main Battery Pack*.
 - Unplug TB2 (pins 1,3,5,7) to deactivate DC or battery/solar power.

This turns on (or shuts OFF) power from either an external power supply or from the battery pack/solar panel.

Note

When you turn power on, the backlight on the HMI module lights, momentarily turns off and then remains lit while the INPUT LED blinks. After approximately one minute the initialization process finishes and the HMI starts to display live data.

4.2 Establishing Communications

The flow computer supports three ways to establish communications: through the host SCADA system, through a local laptop computer running FBxConnect, or through the HMI module.

4.2.1 Communicating with the SCADA Host

Communication to the flow computer through a SCADA host computer requires configuration of the host computer software, which varies depending upon whether you are using OpenEnterprise

or another host software package. Much of this configuration is beyond the scope of this topic, but no matter which host you are using, there are certain steps you must take:

1. Decide how the SCADA host should communicate with the flow computer. This could be through connection with one of the communication ports. A serial port connection could be a cable directly connected to the SCADA host or there could be intermediate connections through a radio or modem. An Ethernet port connection must be through an Ethernet switch with an appropriate Category 5 shielded patch cable.
2. Decide which communication protocol you will use. This could be DNP3, ROC, Modbus, or BSAP. See these documents for more information:
 - *Emerson FB Flow Computer DNP3 Protocol Specifications Manual (D301806X012)*
 - *ROC Protocol Specifications Manual (for Emerson FBx-series) (D301828X012)*
 - *FBxConnect Configuration Software User Manual (D301850X012)*
 - *BSAP Communication Guide for FB1000/FB2000 Series Flow Computers (D301808X012)*
3. Provide the SCADA host with information about the various parameters it needs to extract from the application running in the flow computer. Typically, the SCADA host software includes a utility that allows you to identify this information so it can be incorporated into the database at the SCADA host.
4. Using whatever human-machine interface (HMI) tools exist for the SCADA host, create graphical displays or reports that include the parameters from the application required for successful operator interaction (setpoints, flow variables and so on).

4.2.2 Communicating with a Laptop Using One of the Serial Ports

- If the flow computer is not awake, you must wake it up first. (See *Section 4.3*)
- Your laptop must have Field Tools software with FBxConnect software installed.
- You must know a valid username/password combination for the flow computer.

DANGER

EXPLOSION HAZARD: Ensure the area in which you perform this operation is non-hazardous. Performing this operation in a hazardous area could result in an explosion.

1. Connect a cable between a serial port (or serial/USB adapter) on your laptop and port COM2 on the flow computer.
2. Launch Field Tools and add a new serial connection for this device; this launches FBxConnect configuration software. (If you already have an existing saved serial connection for this device in Field Tools, just double-click on it in the Connections list.)
3. Log into the flow computer if prompted.
4. Use the FBxConnect configuration software to view or change any desired parameters.
5. When finished, log off the flow computer and disconnect the cable from its serial port.

4.2.3 Communicating with a Laptop Using Ethernet

Your laptop must have Field Tools software with FBxConnect software installed.

You must know a valid username/password combination for the flow computer.

DANGER

EXPLOSION HAZARD: Ensure the area in which you perform this operation is non-hazardous. Performing this operation in a hazardous area could result in an explosion.

1. Connect a Category 5 shielded cable between an Ethernet port on your laptop and an Ethernet switch for your network.
2. Connect a Category 5 shielded cable between your Ethernet switch and the Ethernet port on the flow computer.
3. Launch Field Tools and add an IP connection for the device then click **Connect** to start the FBxConnect software. (If you already have an existing saved IP connection for this device in Field Tools, just double-click on it in the Connections list.)
4. Log into the flow computer if prompted.
5. Use the FBxConnect software to view/change any desired parameters.
6. When finished, log off from the flow computer and disconnect the cable.

4.2.4 Communicating with a Laptop Wirelessly with Mobile SCADA

You must have purchased the flow computer with the optional Mobile SCADA feature in order to connect to a laptop PC wirelessly. Additionally:

- Wi-Fi® must be configured and working on your laptop PC.
- Your laptop PC must have Field Tools software with FBxConnect installed.
- You must know a valid username/password combination for the flow computer.
- You must know the name of the wireless network and the security key required to connect to it.
- Your laptop PC must be within line-of-sight with either the front display of the flow computer or of an external antenna for the Mobile SCADA.
- If the flow computer is not awake, you must wake it up first. (See *Section 4.3*)

WARNING

Ensure that you and your laptop PC are in a non-hazardous area.

1. Launch Field Tools software and add a new wireless connection. (If you already have a saved wireless connection for this device in Field Tools, just double-click on it in the Connections list and skip to step 4.)
2. Select the wireless network to which the flow computer belongs and enter the appropriate security key.
3. Click **Connect** to start the FBxConnect software.
4. Log into the flow computer if prompted.
5. Use the FBxConnect software to view or change any desired parameters.

6. When finished, log off the flow computer and disconnect from the wireless network.

4.3 Communicating Using the HMI Module

You must have purchased the flow computer with the HMI module version that includes the optional display. Not all models include the display. Units without the display still include a button to wake up the device and status LEDs.

Note

If the device is configured to require logins to view data, you must know a valid username/password combination for the flow computer.

Note

To conserve power, the HMI module enters sleep mode after a period of inactivity. Sleep mode disables Wi-Fi communication. In FBxConnect, you can configure the number of minutes of inactivity triggering sleep mode through the LCD Sleep Time parameter. Setting this parameter to 0 disables sleep mode which keeps the HMI module on but uses significantly more power.

The operator wakes up the device by holding a finger against the front cover glass over the Hold to Wake button (the left-most button) typically for five to ten seconds. You can also pre-define a number of automatic wake up times during the day from the Power Control screen in FBxConnect.

Exercise care because the more frequent (or more lengthy) the wakeup time, the greater the power usage and the greater the reduction in battery life.

To temporarily keep the HMI module out of sleep mode, maintain an active FBxConnect connection. As long as communications remain active, the HMI module will not sleep.

1. Go to the front of the flow computer and touch your finger on the glass above the **Hold to Wake** button until the display lights up. (This may take several seconds.)
-

Figure 4-1: Waking up the Display



2. If prompted, login using a valid username/password combination. For information on how the buttons work, see [Table 4-1](#).

- The display enters Screen Saver Mode where it sequentially presents a series of screens showing details about meter run flow rates, totals, and current process variables.

Figure 4-2: Infrared (IR) Button Location



- Left Infrared (IR) Button
- Down Infrared (IR) Button
- Up Infrared (IR) Button
- Right Infrared (IR) Button

Note

When using the IR buttons, aim your finger at the round spot just below the arrow.





Table 4-1: Infrared (IR) Buttons on HMI Module

Button	Use to
UP or DOWN buttons	<p><u>Screen Saver Mode</u></p> <ul style="list-style-type: none"> Tap once to move (UP) or (DOWN) one item through list of parameters. Hold to stay on current parameter. <p><u>Data Entry Mode</u></p> <ul style="list-style-type: none"> Tap (UP) once to move the cursor to the previous character in the list or (DOWN) once to move the cursor to the next character in the list. Hold (UP) or (DOWN) to scroll more quickly through the character list.
LEFT button	<p><u>Idle Mode (Screen is off)</u></p> <ul style="list-style-type: none"> Hold to Wake up the display. <p><u>Screen Saver Mode</u></p>

Button	Use to
	<ul style="list-style-type: none"> Log out (if logged in) <p><u>Data Entry Mode</u></p> <ul style="list-style-type: none"> Tap once to move the cursor LEFT.Hold to perform action shown on screen, for example “Hold to Accept”.
RIGHT button	<p><u>Data Entry Mode</u></p> <ul style="list-style-type: none"> Tap once to move the cursor RIGHT.Hold to perform action shown on screen, for example “Hold to Cancel”.

Symbol(s) representing the status of a value may appear in the upper right of the display, next to the description. Multiple symbols may be shown. If there are no data quality issues, no symbols will be shown.

Table 4-2: Symbols on Display

Symbol	Explanation
	Alarm - The parameter value shown is in an alarm state (High Alarm, Low Alarm, etc)
	Override - The parameter value shown is in override mode (i.e. a user entered fixed value)
	Fault - The parameter value shown is somehow invalid
	Unverified - For parameter values that require additional validation (beyond simple database min/max range checking, the parameter value shown has not yet been validated by the firmware).

Section 5: Service and Troubleshooting

This section covers the following topics:

- Returning the Unit for Repairs
- Interpreting the Status LEDs
- Switch and Buttons
- Removing/Replacing the HMI Module
- Replacing the Main Battery Pack
- Removing/Replacing the SRAM Battery
- Upgrading System Firmware

In order to maintain hazardous location certifications, you can only replace components in the field with the exact same part so that the model string on the data plate remains correct. This means you cannot add any hardware not reflected in the model string or upgrade a hardware component to a newer version; any such upgrades are prohibited and void the hazardous location certification. This chapter describes the service tasks that everyone needs to know such as replacing batteries or installing a firmware upgrade. For other field replacements, see the appropriate field replacement guides for that component. Any replacement not covered in this chapter or in the field replacement guides can only be performed at an Emerson-authorized repair facility.

Important

Only use batteries supplied with the flow computer or sold by Emerson Remote Automation Solutions as spare parts for this flow computer. If you substitute a battery you obtain elsewhere you will void your certification unless it is the identical part from the same manufacturer as that supplied with the flow computer from Emerson.

Figure 5-1: FB2200 Flow Computer Components

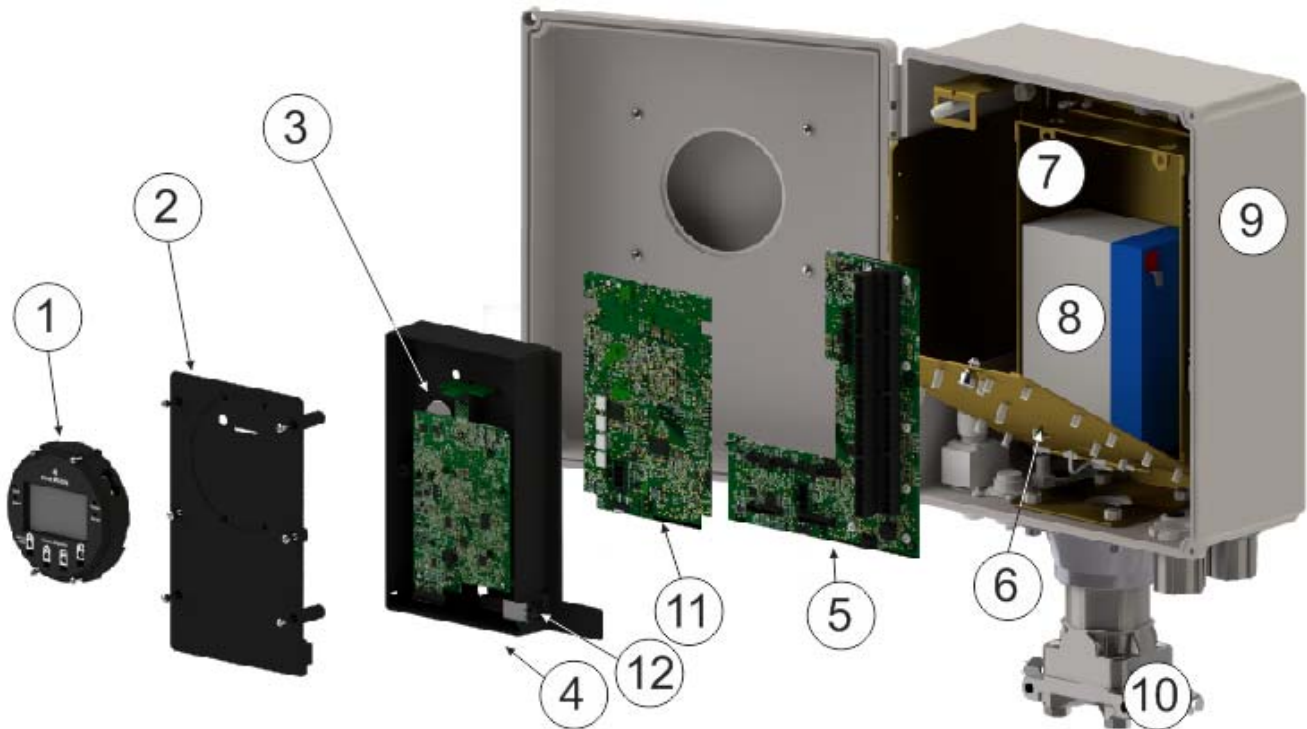

- 1 HMI module
- 2 CPU enclosure cover
- 3 SRAM backup battery
- 4 CPU enclosure
- 5 I/O termination board
- 6 Battery compartment cover
- 7 Battery compartment
- 8 Battery pack
- 9 Enclosure
- 10 Sensor assembly
- 11 8-channel expansion I/O board
- 12 Ethernet port

5.1 Returning the Unit for Repairs

Only certain field replacement procedures are allowed under warranty and hazardous location certification. Other types of repairs cannot be performed in the field. In those cases, you must ship the unit to an Emerson-authorized repair facility. Contact Emerson Remote Automation Solutions for a return authorization number and instructions for where to ship the unit.

⚠ WARNING

International safety regulations restrict the shipment of lithium batteries. If you need to return the flow computer, remove the lithium battery before you ship the unit. Failure to remove the lithium battery may delay or prevent shipment of the flow computer.

5.2 Interpreting the Status LEDs

There are four (4) status LEDs on the flow computer. The meaning of each LED varies depending upon the color displayed or whether the LED flashes.

Figure 5-2: LED Locations



- 1 Input LED
- 2 Link LED
- 3 Status LED
- 4 Alarm LED

Table 5-1: LED Descriptions

LED	Color/State	Meaning
Link LED	GREEN	An active wired Ethernet connection exists. Otherwise it is off. (FB1200/FB2200 only)
Input LED	GREEN	One of the IR buttons is being pressed.
	Flashing YELLOW	CPU booting or CPU has not yet recognized HMI module when HMI first powered on; goes off when recognized.
Status LED	GREEN	OK - Normal
	RED	Unit failed
	YELLOW	Low power source/change battery soon (FB1100 with lithium battery only)
	Off	No power
	Flashing GREEN	System is booting
	Momentary GREEN – approximately every 6 seconds	HMI module is in sleep mode (to reduce power consumption); LED goes on when HMI module checks the “Hold to Wake” IR button.
	Alternating RED, GREEN, YELLOW	HMI module boot firmware loaded but no application is present. You may see this during an HMI firmware update.
Alarm LED	GREEN	No alarms.
	Flashing RED	HMI firmware update in progress.
	RED	Alarms are present.

Table 5-2: Special LED Sequences using Multiple LEDs

LED Sequence	Color/State
Link, Input, Status, and Alarm all solid RED	HMI module failed. Replace with spare or return for repairs.
Link and Alarm alternately flash RED; sequence repeats	CPU stuck in boot mode. Contact technical support.

5.3 Switch and Buttons

A momentary switch and two push buttons on the HMI module provide troubleshooting options for the flow computer.

Figure 5-3: Switch and Buttons



⚠ DANGER

EXPLOSION HAZARD: Never open the enclosure in a hazardous location. Opening the enclosure in a hazardous location could result in an explosion.

Table 5-3: Switch and Buttons

Button Name	Purpose	Procedure
SYSTEM RESET	Resets Power. This momentary switch Interrupts power to the flow computer to reset it. Used if system powered on but non-functional; this attempts a reboot.	Move the SYSTEM RESET switch either up or down. Unit powers off and then restarts.
A	Clears memory (SRAM). The SRAM memory holds current data values and pending alarm messages. If unit has unexpectedly stopped operating, you can depress this button on power-up to clear that information from memory (hard reset). Try this if a SYSTEM RESET alone does not work.	<ol style="list-style-type: none"> 1. Press and hold the A button. 2. While continuing to hold the A button, move the SYSTEM RESET switch either up or down to initiate a reset. 3. Release the A button. The system clears SRAM during the power up sequence.
B	Currently undefined	None

5.4 Removing/Replacing the HMI Module

You do not need to power down the unit to replace the HMI module.

⚠ DANGER

Ensure the flow computer is in a non-hazardous area. Never remove/replace the HMI module in a hazardous area.

1. Open the enclosure.
2. Loosen the four captive fastening screws on the HMI module.

Figure 5-4: Captive Fastening Screws



3. Grasp the HMI module and remove it by gently pulling it straight out.
4. To replace the HMI module, line up the printed circuit board (PCB) with the slot on the back and gently press it back on. Tighten the four captive fastening screws.
5. Close the enclosure.

5.5 Replacing the Main Battery Pack

Periodically you must replace the main battery pack. FBxConnect provides a battery life indicator showing the number of days in use to help you monitor battery life.

Figure 5-5: Main Battery Pack



The device provides a battery cable with two pairs of battery connectors, enabling you to hot-swap the battery pack in a non-hazardous location. Attach the new battery pack to the free connector (leaving the old one connected), and then disconnect the old battery pack.

DANGER

EXPLOSION HAZARD: Ensure the area in which you perform this operation is non-hazardous. Performing this operation in a hazardous area could result in an explosion.

DANGER

EXPLOSION HAZARD: Do not disconnect equipment unless power has been removed or the area is known to be non-hazardous.

DANGER

EXPLOSION HAZARD: Substitution of any components may impair suitability for Class I, Division 2.

DANGER

EXPLOSION HAZARD: Do not replace batteries unless power has been switched off or the area is known to be non-hazardous. Batteries must only be changed in an area known to be non-hazardous.

⚠ WARNING

There are no user-serviceable parts inside the battery pack. Do not open the battery pack as you may damage the battery pack or injure yourself.

You will need a Phillips-head screwdriver to perform this procedure.

Keep the replacement battery pack handy during the procedure.

1. Remove the plastic tabs covering the connectors on the new battery pack.
-

Figure 5-6: Removing Plastic Tabs from New Battery Pack



2. Open the enclosure.

3. Loosen the two captive fastening screws at the top of the of the battery compartment and carefully rotate the electronics assembly towards you to reveal the inside of the battery compartment. A strap prevents the front of the compartment from rotating too far forward.

Figure 5-7: Loosen Captive Fastening Screws and Rotate Assembly Forward

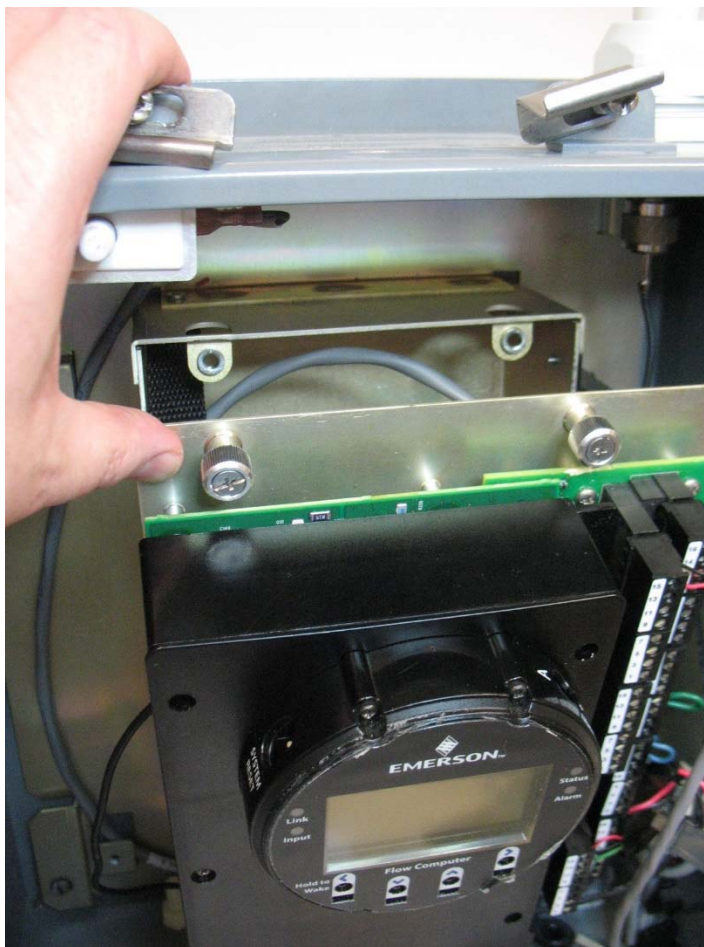

4. Remove the battery:
If a hook and loop pad holds the battery, see the instructions in Step 5.
If a strap holds the battery, skip to Steps 6 and 7.
5. Follow this step if you have the configuration where a hook-and-loop pad on the back of the battery secures it to the back of the battery compartment (otherwise skip to Steps 6 and 7). Leave the connectors on the current battery connected. Place your fingers behind the battery pack and pry it off of the fastener on the back of the compartment; you may need to use both hands. Gently lift the battery with the battery cable attached out of the compartment. Now skip to Step 8.

Figure 5-8: Pry Out the Old Battery Pack – Leave Connected to Cable



6. If you have an internal solar regulator installed in the battery compartment, you must remove the termination cover. Remove the two screws (left and right) that fasten the termination cover to the solar regulator, and then set the termination cover aside. (If you don't have an internal solar regulator, skip to Step 7.)

Figure 5-9: Removing the Termination Cover (if present)



7. A strap with a hook and loop fastener holds the battery in place. Unstrap the battery but leave the connectors on the current battery connected. Gently lift the battery with the battery cable attached out of the compartment.

Figure 5-10: Unstrap the Old Battery Pack – Leave Connected to Cable



8. Place the old battery on top of the flow computer enclosure and place the new battery next to it.

Figure 5-11: Old Battery (left) and New Battery (right) Sit on Enclosure



9. The battery cable is divided into two branches, each with its own pair of connectors. Take the free pair of connectors and connect them to the **new** battery; the red (positive) wire connector attaches to the red connection point on the new battery and the black (negative) wire connector attaches to the black connection point on the new battery.

Figure 5-12: Connect New Battery – Both Now Connected



10. Now disconnect the **old** battery from its connectors and set the old battery aside (be sure to dispose of it safely according to local regulations).

Figure 5-13: Old Battery Disconnected (left), New Battery Remains Connected (right)

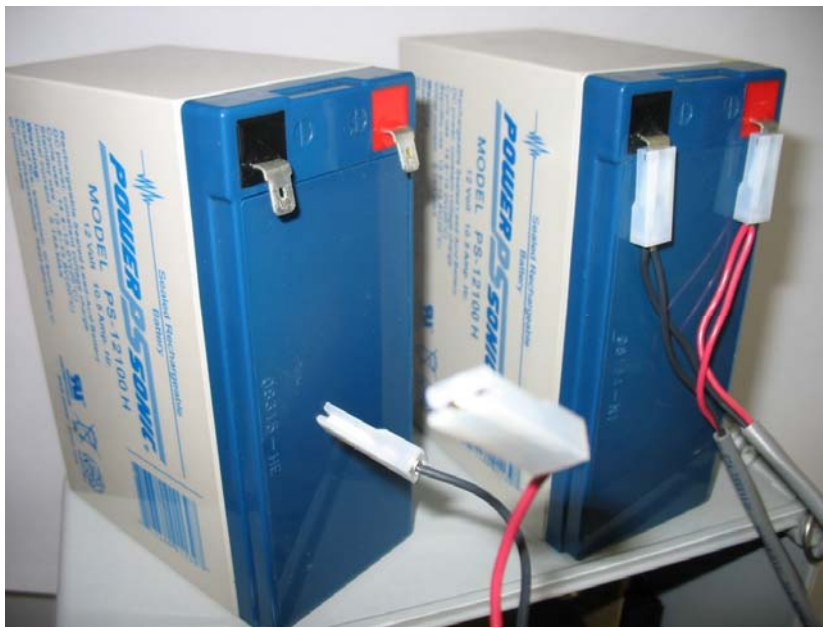

11. Put the battery in the battery compartment:
 - If a hook and loop pad holds the battery, see the instructions in Step 12.
 - If a strap holds the battery, skip to Steps 13 through 18.
12. Pick up the new battery and align it with the lower left edge of the battery compartment. Press it against the back of the compartment so the fastener pad on the back of the battery secures to the back of the battery compartment. Route the wires of the free portion of the battery cable so that they sit in the open area at the top of the battery compartment. Skip to Step 19.
13. Thread the battery strap through the holes of the battery compartment, if it is not already threaded.

Figure 5-14: Threading the Battery Strap



14. Pick up the new battery and carefully ease it into the battery compartment with the writing on the battery facing out and the connectors on the upper right-hand side. Nothing (including the strap) can be **behind** the battery.

Figure 5-15: Easing the Battery into the Battery Compartment



15. Carefully push the battery under the solar regulator (if present) and against the back of the compartment, now strap it in tightly by pulling the ends of the strap.

Figure 5-16: Tightening the Battery Strap



16. The strap includes a narrow opening into which you can slide the other end of the strap to help you tighten it.

Figure 5-17: Opening in the Battery Strap



17. Route the extra portion of the strap as well as the wires of the free portion of the battery cable so that they sit in an open area of the battery compartment.
18. If you had to remove the termination cover of an internal solar regulator (Step 6), re-attach the termination cover.
19. Rotate the electronics assembly up against the battery compartment and tighten the captive fastening screws with a torque value of 2 to 4 in-lbs (0.2 to 0.5 N m) to close the compartment.
20. Close the enclosure.

5.6 Removing/Replacing the SRAM Battery

A lithium coin cell battery provides backup power for the SRAM and the real time clock. The SRAM backup battery can last for up to 10,000 hours of cumulative operation, and only runs if the main power system fails. You do not need to power down the unit to replace the SRAM backup battery.

Important

If the unit is ever powered down without the SRAM battery installed, SRAM data is lost. Always back up your data **before** you remove the SRAM battery if you know that main power will also be off.

Important

Replacement SRAM backup batteries must be Rayovac® Model BR2335.

DANGER

Ensure the flow computer is in a non-hazardous area. Never open the enclosure in a hazardous area.

DANGER

EXPLOSION HAZARD: Do not disconnect equipment unless power has been removed or the area is known to be non-hazardous.

DANGER

EXPLOSION HAZARD: Substitution of any components may impair suitability for Class I, Division 2.

DANGER

EXPLOSION HAZARD: Do not replace batteries unless power has been switched off or the area is known to be non-hazardous. Batteries must only be changed in an area known to be non-hazardous.

1. Open the enclosure.

2. Loosen the two captive fastening screws on the cover of the black CPU enclosure (which has the HMI module attached to it) and place it aside.

Figure 5-18: Loosen Captive Fastening Screws

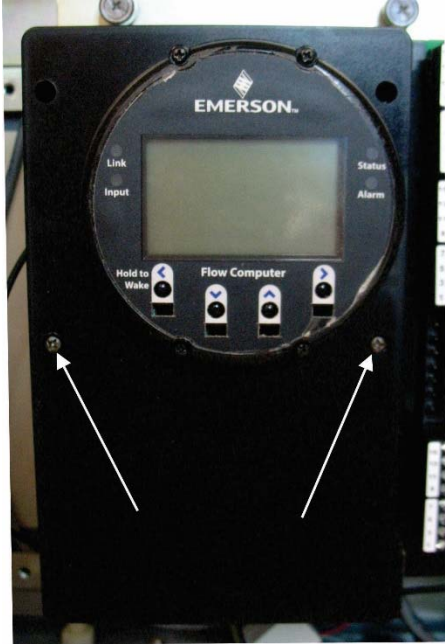
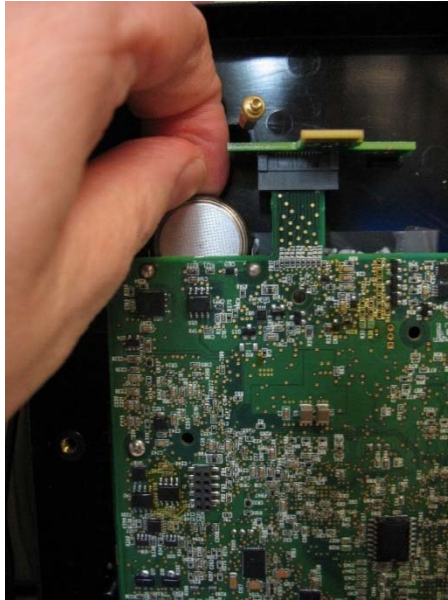

Figure 5-19: Removing the CPU Enclosure Cover



3. Grasp the coin cell battery and with your fingernail in the groove of the top of the battery, slide it out of its slot.

Figure 5-20: Coin Cell Battery Removal/Replacement



4. Insert the new coin cell battery in the slot. The negative side (shiny side with no writing on it) must be facing outwards (towards where the CPU enclosure cover would be).
5. Reattach the cover of the CPU enclosure.
6. Close the enclosure.

5.7 Upgrading System Firmware

Periodically Emerson releases new system firmware for the flow computer to introduce new features or update system functions.

You must know a valid username/password combination for the flow computer to complete this process.

⚠ DANGER

EXPLOSION HAZARD: Ensure the area in which you perform this operation is non-hazardous. Performing this operation in a hazardous area could result in an explosion.

1. Launch Field Tools and use FBxConnect to connect to the flow computer.
2. Click the **Services** tab, then click **Firmware Update**.
3. Click **Configuration Save** to save the flow computer's configuration.
4. Click **History Collection** to save the historical data contained in the flow computer.
5. Click **Firmware Update**.

6. In the Firmware Update dialog box, click **Browse** and navigate to the zip file containing your new system firmware. The grid updates with details of the firmware version currently in the device, and the firmware version in the zip file.

Figure 5-21: Firmware Update Dialog Box

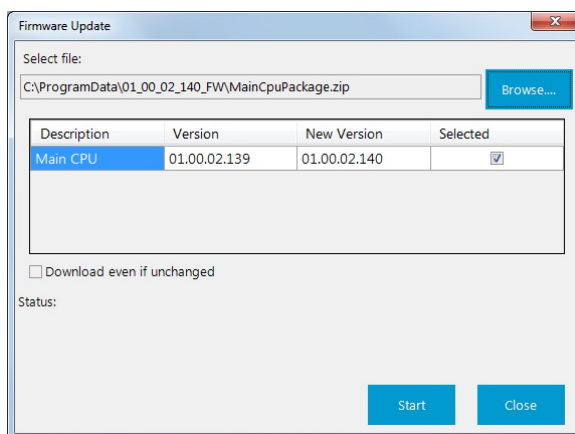

7. Select the checkbox in the **Selected** column to choose the firmware. If you are downloading the **same** version that is already installed on the device, select **Download Even If Unchanged**.
8. Click **Start** to begin the firmware download. Allow the download to proceed to completion. If you choose to cancel the firmware download before it completes, the system restores the current version already in the device.

Appendix A: Special Instructions for Class I Division 2 Locations

1. The Emerson FB2200 flow computer is listed by Underwriters Laboratories (UL) as non-incendive and is suitable for use in Class I, Division 2, Groups A, B, C and D hazardous locations or nonhazardous locations. Read this appendix carefully before installing a non-incendive Emerson FB2200 flow computer. Refer to the other chapters of this manual for general information. In the event of a conflict between the other chapters of this manual and this appendix, always follow the instructions in this appendix.
2. The Emerson FB2200 flow computer includes both nonincendive and unrated field circuits. Unless a circuit is specifically identified in this appendix as nonincendive, the circuit is unrated. Unrated circuits must be wired using wiring methods as specified in *Article 501-4(b) of the National Electrical Code (NEC), NFPA 70* for installations in the United States, or as specified in *Section 18-152 of the Canadian Electrical Code* for installation in Canada.
3. All communication ports terminate on the terminal plate within the enclosure. Wiring to the connectors is unrated. No connections may be made to communication ports unless the user ensures that the area is known to be nonhazardous. Connections to the "Local Port" are temporary and must be short in duration to ensure that flammable concentrations do not accumulate while it is in use.
4. An RTD may be supplied with the Emerson FB2200 flow computer. Connection to the RTD is approved as a nonincendive circuit so that Division 2 wiring methods are not required.
5. I/O connections are unrated and must be wired using Division 2 wiring methods.

DANGER

EXPLOSION HAZARD: Do not disconnect equipment unless power has been removed or the area is known to be non-hazardous.

DANGER

EXPLOSION HAZARD: Substitution of any components may impair suitability for Class I, Division 2.

DANGER

EXPLOSION HAZARD: Do not replace batteries unless power has been switched off or the area is known to be non-hazardous. Batteries must only be changed in an area known to be non-hazardous.

Figure A-1: Data Plate (FIBERGLASS ENCLOSURE, NO BATTERY) - Class I Division 2 Nonincendive (UL)

P/N 399429-01-0

EMERSON.

Flow Computer REMOTE AUTOMATION SOLUTIONS

FB2200 RATINGS, INPUT VOLTAGE: 10.5-30VDC RATINGS, POWER: 10 WATTS MAX
AMBIENT TEMP RANGE: -35°C TO 80°C CL I, DIV 2 GROUPS A, B, C, D . TEMPERATURE CODE: T4

S/N

MODEL CONFIG.

DATE MFD.

Fromex S.A. de C.V. Nuevo Laredo. Tamaulipas. Mexico

WARNING:
EXPLOSION HAZARD-BATTERIES MUST ONLY BE CHANGED IN AN AREA KNOWN TO BE NON-HAZARDOUS .
WARNING: DO NOT CONNECT OR DISCONNECT WHEN THE AREA IS KNOWN TO BE HAZARDOUS.
AVERTISSEMENT: EXPLOSION BATTERIES DE DANGER ne doit être changé dans une région connue comme non dangereux.
AVERTISSEMENT Ne pas connecter ou déconnecter lorsque la zone est connu pour être dangereux.
COMPLIES WITH FCC CLASS A LIMITS. THIS DEVICE COMPLIES WITH PART 15 OF THE FCC RULES.
BATTERY - NONE

 REFER TO THE USER MANUAL FOR ADDITIONAL INSTALLATION INSTRUCTIONS





  

Figure A-2: Data Plate (FIBERGLASS ENCLOSURE, LEAD ACID BATTERY) - Class I Division 2 Nonincendive (UL)

P/N 399425-01-0

EMERSON.

Flow Computer REMOTE AUTOMATION SOLUTIONS

FB2200 RATINGS, INPUT VOLTAGE: 10.5-30VDC RATINGS, POWER: 10 WATTS MAX
AMBIENT TEMP RANGE: -35°C TO 45°C CL I, DIV 2 GROUPS A, B, C, D . TEMPERATURE CODE: T4

S/N

MODEL CONFIG.

DATE MFD.

Fromex S.A. de C.V. Nuevo Laredo. Tamaulipas. Mexico

WARNING:
EXPLOSION HAZARD-BATTERIES MUST ONLY BE CHANGED IN AN AREA KNOWN TO BE NON-HAZARDOUS .
WARNING: DO NOT CONNECT OR DISCONNECT WHEN THE AREA IS KNOWN TO BE HAZARDOUS.
AVERTISSEMENT: EXPLOSION BATTERIES DE DANGER ne doit être changé dans une région connue comme non dangereux.
AVERTISSEMENT Ne pas connecter ou déconnecter lorsque la zone est connu pour être dangereux.
COMPLIES WITH FCC CLASS A LIMITS. THIS DEVICE COMPLIES WITH PART 15 OF THE FCC RULES.
BATTERY - SEALED RECHARGEABLE LEAD-ACID 12.0 VDC 10.5 Ah P/N 399285-01-0

 REFER TO THE USER MANUAL FOR ADDITIONAL INSTALLATION INSTRUCTIONS





  

Figure A-3: Data Plate (FIBERGLASS ENCLOSURE, NO BATTERY, RELAY) - Class I Division 2 Nonincendive (UL)

P/N 399435-01-0

EMERSON.

Flow Computer REMOTE AUTOMATION SOLUTIONS

FB2200 RATINGS, INPUT VOLTAGE: 10.5-30VDC RATINGS, POWER: 10 WATTS MAX
AMBIENT TEMP RANGE: -35°C TO 60°C CL I, DIV 2 GROUPS A, B, C, D . TEMPERATURE CODE: T4

S/N

MODEL CONFIG.

DATE MFD.

Fromex S.A. de C.V. Nuevo Laredo. Tamaulipas. Mexico

WARNING:
EXPLOSION HAZARD-BATTERIES MUST ONLY BE CHANGED IN AN AREA KNOWN TO BE NON-HAZARDOUS .
WARNING: DO NOT CONNECT OR DISCONNECT WHEN THE AREA IS KNOWN TO BE HAZARDOUS.
AVERTISSEMENT: EXPLOSION BATTERIES DE DANGER ne doit être changé dans une région connue comme non dangereux.
AVERTISSEMENT Ne pas connecter ou déconnecter lorsque la zone est connu pour être dangereux.
COMPLIES WITH FCC CLASS A LIMITS. THIS DEVICE COMPLIES WITH PART 15 OF THE FCC RULES.
BATTERY - NONE

 REFER TO THE USER MANUAL FOR ADDITIONAL INSTALLATION INSTRUCTIONS





  

Figure A-4: Data Plate (ALUMINUM ENCLOSURE, NO BATTERY) - Class I Division 2 Nonincendive (UL)

P/N 399431-01-0

EMERSON.

Flow Computer REMOTE AUTOMATION SOLUTIONS

FB2200 RATINGS, INPUT VOLTAGE: 10.5-30VDC RATINGS, POWER: 10 WATTS MAX
AMBIENT TEMP RANGE: -40°C TO 80°C CL I, DIV 2 GROUPS A, B, C, D . TEMPERATURE CODE: T4

S/N

MODEL CONFIG.

DATE MFD.

Fromex S.A. de C.V. Nuevo Laredo. Tamaulipas. Mexico

WARNING:
EXPLOSION HAZARD-BATTERIES MUST ONLY BE CHANGED IN AN AREA KNOWN TO BE NON-HAZARDOUS .
WARNING: DO NOT CONNECT OR DISCONNECT WHEN THE AREA IS KNOWN TO BE HAZARDOUS.
AVERTISSEMENT: EXPLOSION BATTERIES DE DANGER ne doit être changé dans une région connue comme non dangereux.
AVERTISSEMENT Ne pas connecter ou déconnecter lorsque la zone est connu pour être dangereux.
COMPLIES WITH FCC CLASS A LIMITS. THIS DEVICE COMPLIES WITH PART 15 OF THE FCC RULES.
BATTERY - NONE

 REFER TO THE USER MANUAL FOR ADDITIONAL INSTALLATION INSTRUCTIONS



  

Figure A-5: Data Plate (ALUMINUM ENCLOSURE, LEAD ACID BATTERY) - Class I Division 2 Non-incendive (UL)











P/N 399345-01-0	
 EMERSON.	
Flow Computer REMOTE AUTOMATION SOLUTIONS	
FB2200 RATINGS, INPUT VOLTAGE: 10.5-30VDC RATINGS, POWER: 10 WATTS MAX AMBIENT TEMP RANGE: -40°C TO 45°C CL I, DIV 2 GROUPS A, B, C, D . TEMPERATURE CODE: T4	
S/N	
MODEL CONFIG.	
DATE MFD.	
Fromex S.A. de C.V. Nuevo Laredo. Tamaulipas. Mexico	
WARNING: EXPLOSION HAZARD-BATTERIES MUST ONLY BE CHANGED IN AN AREA KNOWN TO BE NON-HAZARDOUS . WARNING: DO NOT CONNECT OR DISCONNECT WHEN THE AREA IS KNOWN TO BE HAZARDOUS. AVERTISSEMENT: EXPLOSION BATTERIES DE DANGER ne doit être changé dans une région connue comme non dangereux. AVERTISSEMENT Ne pas connecter ou déconnecter lorsque la zone est connu pour être dangereux.	
COMPLIES WITH FCC CLASS A LIMITS. THIS DEVICE COMPLIES WITH PART 15 OF THE FCC RULES.	
BATTERY - SEALED RECHARGEABLE LEAD-ACID 12.0 VDC 10.5 Ah P/N 399285-01-0	
 REFER TO THE USER MANUAL FOR ADDITIONAL INSTALLATION INSTRUCTIONS	  

Figure A-6: Data Plate (ALUMINUM ENCLOSURE, NO BATTERY, RELAY) - Class I Division 2 Non-incendive (UL)

P/N 399434-01-0	
 EMERSON.	
Flow Computer REMOTE AUTOMATION SOLUTIONS	
FB2200 RATINGS, INPUT VOLTAGE: 10.5-30VDC RATINGS, POWER: 10 WATTS MAX AMBIENT TEMP RANGE: -40°C TO 60°C CL I, DIV 2 GROUPS A, B, C, D . TEMPERATURE CODE: T4	
S/N	
MODEL CONFIG.	
DATE MFD.	
Fromex S.A. de C.V. Nuevo Laredo. Tamaulipas. Mexico	
WARNING: EXPLOSION HAZARD-BATTERIES MUST ONLY BE CHANGED IN AN AREA KNOWN TO BE NON-HAZARDOUS . WARNING: DO NOT CONNECT OR DISCONNECT WHEN THE AREA IS KNOWN TO BE HAZARDOUS. AVERTISSEMENT: EXPLOSION BATTERIES DE DANGER ne doit être changé dans une région connue comme non dangereux. AVERTISSEMENT Ne pas connecter ou déconnecter lorsque la zone est connu pour être dangereux.	
COMPLIES WITH FCC CLASS A LIMITS. THIS DEVICE COMPLIES WITH PART 15 OF THE FCC RULES.	
BATTERY - NONE	
 REFER TO THE USER MANUAL FOR ADDITIONAL INSTALLATION INSTRUCTIONS	  

Appendix B: ATEX Non-Sparking Zone 2 Certifications

This appendix includes notes on ATEX certifications. For full details, please refer to the *Emerson FB2200 Flow Computer Safe Use Instructions* (D301801X012).

Special Conditions of Use:

- Use equipment in an area of not more than pollution degree 2.
- Make provisions to ensure, in the event of transient disturbances, that the rated voltage does not exceed 140 percent of the peak rated voltage.
- Lead acid battery, and solar power options are not for use in ATEX applications.
- Impact tests on the display were conducted based on Group II values for the low risk of mechanical danger, in accordance with *Table 13 of both EN 60079-0:2012+A11:2013 and IEC 60079-0 6th Edition*. Install flow computers with displays in areas where the risk of impact is low.
- For Zone 2 installations, ensure that the flow computer is installed and used in such a way so as to prevent the danger of electrostatic charges.
- The FB2200 enclosure must require a tool to permit access.
- Refer to field replacement guides for replacement of the following parts:

Replacement Part	Kit Number	Field Replacement Guide document number:
8-Channel Expansion I/O Board	400217010-KIT	D301804X012
6-Channel Expansion I/O Board	400215010-KIT	D301803X012
HMI Module Display Assembly	399379-01-0, 621627011-KIT, 399380-01-0, 621627020-KIT	D301822X012
I/O Termination Board	400210010-KIT, 358807010-KIT	D301805X012
CPU Enclosure and Electronics	621673-01-0, 621674-01-0, 621675-01-0, 621676-01-0, 621678-01-0, 400209010-KIT, 399260-01-0, 399264-01-0, 400211010-KIT	D301803X012
Sensor	Variable Kit Number	D301843X012
Door Accessories	399291-01-0, 399267-01-0, 399266-01-0,	D301825X012

	621661010-KIT, 399394-00-0	
Relay	395828-01-0	D301847X012
Coin Cell Battery	395620-03-1	D301855X012

This device was evaluated according to the following standards:

- IEC 60079-0 6th Edition
- IEC 60079-15 4th Edition
- EN 60079-0 :2012+A11:2013
- EN 60079-15:2010

Enclosure Rating: IP54

Terminal blocks for the FB2200 have the following characteristics:

- Terminal blocks can accommodate two conductors per channel.
- Stranded or solid wire allowed.
- Torque values: NM 0.5-0.6
- Wire size: 28-12 AWG; (0.08 – 3.3 mm²); (0.32 – 2.05 mm)

Bristol Inc. d.b.a. Remote Automation Solutions

1100 Buckingham Street

Watertown, CT 06795 U.S.A.

Figure B-1: Data Plate (NO BATTERY) – ATEX nA Non-Sparking

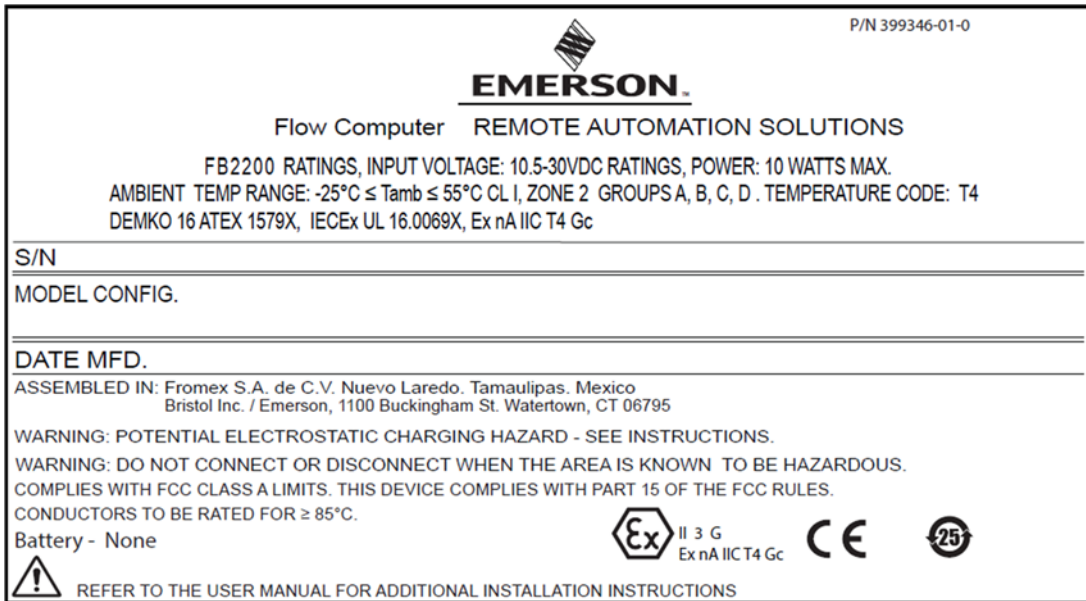

Index

4

4088B transmitter77

A

AI Wiring.....66

Analog Inputs65

Analog Outputs67

AO Wiring.....68

Application software.....9

ATEX certification
notes about.....111

B

Battery

connecting.....36

low power status LED90

replacing the main battery pack93

replacing the SRAM backup battery.....102

shipping restrictions.....89

Bolting.....22

Buttons.....91

C

Case

rotating.....30

Class I Division 2.....107

Closing the enclosure.....21

COM1

wiring.....55

COM2

wiring.....58

COM3

wiring.....58

Communicating using the HMI Module84

Communicating via a serial port.....82

Communication

establishing.....81

to a laptop through an Ethernet port82

to a laptop using a wireless connection.....83

to laptop through a serial port82

with SCADA Host.....81

Communication ports

connecting.....55

overview7

Configuration software9

Connecting

battery.....36

Ethernet.....60

I/O.....63

power.....34

PRT.....75

RTD.....75

run 2 transmitter77

CPU.....5

D

Daily operation81

DC power

connecting.....34

DI Wiring.....70

Digital Inputs69

Digital Outputs71

wiring to a relay.....79

Display

replacing92

DO Wiring.....72

E

Enclosure

mounting the22

Environmental specifications13

Equipment required for servicing the unit14

Ethernet

communications82

connecting.....60

F

Features.....3

Figures

1-1. FB2200 Flow Computer2

1-2. FB2200 Flow Computer – MV Version4

1-3. FB2200 Flow Computer – No Sensor Version ..5

1-4. HMI Module with LCD8

1-5. HMI Module without LCD.....8

1-6. Locations Where Padlocks Can Be Used10

1-7. Removing cap and latch from Fiberglass
Enclosure10

1-8. Locations Where Customer Can Apply Tamper-
Evident Tape.....11

2-1. FB2200 Dimensions – Multivariable Sensor Version -Fiberglass Enclosure	15	2-40. Adjusting the 30W Solar Panel Tilt Angle	54
2-2. FB2200 Dimensions – Multivariable Sensor Version - Aluminum Enclosure	16	2-41. Connecting a Device to COM1 Using RS-23255	
2-3. FB2200 Dimensions – No Integral Sensor Version - Fiberglass Enclosure	17	2-42. Connecting a Device to COM1 Using RS-42256	
2-4. FB2200 Dimensions – No Integral Sensor Version – Aluminum Enclosure	18	2-43. Connecting a Device to COM1 Using RS-48557	
2-5. Dimensions – Static Pressure Sensor Version – Fiberglass Enclosure	19	2-44. Connecting a Device to COM2 or COM3 Using RS-232.....	58
2-6. Dimensions – Static Pressure Sensor Version – Aluminum Enclosure.....	20	2-45. Connecting a Device to COM2 or COM3 Using RS-485.....	59
2-7. Fiberglass Enclosure Fasteners.....	22	2-46. Location of Ethernet Port.....	60
2-8. Aluminum Enclosure Clamps.....	22	2-47. Ethernet Jumper	61
2-9. Transmitter with Coplanar Flange.....	23	2-48. Wiring the Security Intrusion Switch	62
2-10. Transmitter with Coplanar Flange and Optional Flange Adapters	23	2-49. Board Info Screen in FBxConnect	62
2-11. Transmitter with Traditional Flange and Optional Flange Adapters	23	3-1. Base I/O	64
2-12. Proper Bolt Installation	24	3-2. Wiring for 8-channel expansion I/O board and 6-channel expansion I/O board	65
2-13. O-rings with Flange Adapters	25	3-3. Analog Input (AI) Wiring – Base I/O always present	66
2-14. Aluminum Enclosure Pole Mounting.....	26	3-4. Analog Input (AI) Wiring – (Optional 8-channel expansion I/O board and optional 6-channel expansion I/O board)	67
2-15. Fiberglass Enclosure Pole Mounting.....	27	3-5. Analog Output (AO) Wiring – (Base I/O – always present).....	68
2-16. Aluminum Enclosure Panel or Wall Mounting	28	3-6. Analog Output (AO) Wiring – (Optional 8- channel expansion I/O board and optional 6- channel expansion I/O board)	69
2-17. Attaching mounting tabs	29	3-7. Digital Input (DI) Wiring – (Base I/O – always present).....	70
2-18. Fiberglass Enclosure Panel or Wall Mounting	30	3-8. Digital Input (DI) Wiring – (Optional Mixed I/O boards).....	71
2-19. Housing Rotation Set Screw (1 each side)	31	3-9. Digital Output (DO) Wiring – (Base I/O – always present).....	72
2-20. DC Power Connections	35	3-10. Digital Output (DO) Wiring – (Optional 8- channel expansion I/O board and optional 6- channel expansion I/O board)	73
2-21. Removing Plastic Tabs from Battery Pack.....	36	3-11. Pulse Input (PI) Wiring - (Base I/O – always present).....	74
2-22. Captive Fastening Screws	37	3-12. Pulse Input (PI) Wiring – (Optional Mixed I/O boards).....	75
2-23. Rotate Assembly Forward.....	38	3-13. Wiring for 2-Wire.....	76
2-24. Connect the Battery	39	3-14. Wiring for 3-Wire.....	76
2-25. Removing Termination Cover of Internal Solar Regulator	40	3-15. Wiring for 4-Wire.....	77
2-26. Battery Strap	41	3-16. Connecting a 4088B Transmitter for a Second Meter Run.....	78
2-27. Easing Battery Pack into Compartment	42	3-17. Relay Wired to Isolated DO	79
2-28. Battery Pack Attached to Compartment	42	3-18. Relay Wired to Non-Isolated DO	80
2-29. Battery Pack Attached to Compartment	43	3-19. Radio Wiring.....	80
2-30. Battery Pack Attached to Compartment	44	4-1. Waking up the Display	84
2-31. Battery pack attached to compartment.....	46	4-2. Infrared (IR) Button Location.....	85
2-32. Removing Fork Connectors	47	5-1. FB2200 Flow Computer Components	88
2-33. Wiring Solar Power	47		
2-34. Wiring Solar Power	48		
2-35. Routing Battery Wires	48		
2-36. Wiring Solar Power	49		
2-37. Wiring Solar Power-Internal.....	50		
2-38. Installing 30W Solar Panel	51		
2-39. 30W Solar Panel Installed	52		

5-2. LED Locations89
5-3. Switch and Buttons91
5-4. Captive Fastening Screws92
5-5. Main Battery Pack.....93
5-6. Removing Plastic Tabs from New Battery Pack
.....94
5-7. Loosen Captive Fastening Screws and Rotate
Assembly Forward95
5-8. Pry out the old battery pack – leave connected
to cable96
5-9. Removing the Termination Cover (if present) 97
5-10. Unstrap the Old Battery Pack – Leave
Connected to Cable97
5-11. Old Battery (left) and New Battery (right) Sit
on Enclosure98
5-12. Connect New Battery – Both Now Connected
.....98
5-13. Old battery disconnected, new battery
connected99
5-14. Threading the Battery Strap..... 100
5-15. Easing the Battery into the Battery
Compartment 100
5-16. Tightening the Battery Strap 101
5-17. Opening in the Battery Strap 101
5-18. Loosen the captive fastening screws..... 103
5-19. Removing the CPU Enclosure Cover..... 103
5-20. Coin Cell Battery Removal/Replacement ... 104
5-21. Firmware Update Dialog Box 105
A-1. Data Plate (fiberglass enclosure, no battery) -
Class I Division 2 Nonincendive (UL) 108
A-2. Data Plate (fiberglass enclosure, lead acid
battery) - Class I Division 2 Nonincendive (UL) .108
A-3. Data Plate (fiberglass enclosure, no batt, relay) -
Class I Division 2 Nonincendive (UL) 109
A-4. Data Plate (ALUMINUM ENCLOSURE, NO
BATTERY) - Class I Division 2 Nonincendive (UL)
..... 109
A-5. Data Plate (aluminum encl, lead acid batt) -
Class I Division 2 Non-incendive (UL) 110
A-6. Data Plate (aluminum encl, no batt,relay) -
Class I Division 2 Non-incendive (UL) 110
B-1. Data Plate (No battery) – ATEX nA Non-
Sparking 112
Firmware
upgrading the 104
G
Grounding21

H
Hazardous locations
ATEX Zone 2 111
Class I Division 2 107
Hazardous Locations 13
HMI module
replacing 92
HMI Module 7
Housing
rotating 30
I
I/O
configuration and wiring 63
options..... 5
Installation 13
L
LCD
replacing 92
LEDs
meaning of 89
M
Memory 5
amount of FLASH..... 5
amount of SRAM 5
clearing SRAM 91
Mobile SCADA.....8, 83
Mounting
aluminum enclosure 26
bolting considerations 22
fiberglass enclosure 27
panel or wall mount
aluminum enclosure 28
fiberglass enclosure 29
N
Non-sparking
ATEX Zone 2 certification notes 111
O
Opening the enclosure 21
Operation 81
O-rings 25
P
Physical Security 9
PI Wiring 74
Ports

connecting.....	55
Power	
connecting.....	34
modes.....	31
options.....	6
turning ON or OFF	81
PRT	
connecting.....	75
Pulse Inputs	73
Push buttons.....	91
R	
Radio	
Wiring.....	80
Relay	
Wiring to a DO	79
Resetting the flow computer.....	91
Returning the Unit for Repairs	88
RoHS2 Compliance	9
Rotating the housing	30
RTD	
connecting.....	75
Run2 transmitter	
connecting.....	77
S	
Safety Labels.....	2
Screen Saver Mode	85
Second meter run	
connections for	77
Security Intrusion Switch.....	62
Serial communication	82
Service.....	87
Site considerations.....	15
Software Tools	9
Solar panel	
adjusting the tilt angle.....	53
installing the optional 30W	50
Solar power	
connecting.....	45
SRAM	
clearing	91
Status LEDs	89
Switch.....	91
System firmware	

upgrading the	104
SYSTEM RESET button	91

T

Tables	
1-1. Memory	5
1-2. FB2200 I/O Configurations	6
1-3. Power Options.....	7
1-4. Serial Ports.....	7
2-1. Environmental Specifications.....	14
2-2. Required Tools	14
2-3. Torque Values for the Flange and Flange Adapter Bolts.....	24
2-4. Typical Power Usage– Low Power Mode.....	32
2-5. Typical Power Usage – Standard Power Mode	33
2-6. Solar Panel Electrical Characteristics	45
2-7. Solar Regulator Electrical Characteristics	46
2-8. Solar Panel Tilt Angle	53
3-1. Analog Input Characteristics.....	66
3-2. Analog Output Characteristics.....	68
3-3. Digital input Characteristics.....	70
3-4. Digital Output Characteristics.....	71
3-5. Pulse Input Characteristics.....	74
4-1. Infrared (IR) Buttons on HMI Module.....	85
4-2. Symbols on Display.....	86
5-1. LED Descriptions	90
5-2. Special LED Sequences	90
5-3. Buttons	91
Tools required.....	14
Troubleshooting	87

W

Wi-Fi	8, 83
Wiring	
AI	66
AO.....	68
DI	70
DO	72
guidelines.....	20
I/O.....	63
PI	74

Z

Zone 2	
ATEX certification notes	111

For customer service and technical support, visit www.Emerson.com/SupportNet

Global Headquarters,

North America, and Latin America:

Emerson Automation Solutions
Remote Automation Solutions
6005 Rogerdale Road
Houston, TX 77072 U.S.A.
T +1 281 879 2699 | F +1 281 988 4445
www.Emerson.com/RemoteAutomation

Europe:

Emerson Automation Solutions
Remote Automation Solutions
Unit 8, Waterfront Business Park
Dudley Road, Brierley Hill
Dudley UK DY5 1LX
T +44 1384 487200 | F +44 1384 487258

Middle East/Africa:

Emerson Automation Solutions
Remote Automation Solutions
Emerson FZE
P.O. Box 17033
Jebel Ali Free Zone – South 2
Dubai U.A.E.
T +971 4 8118100 | F +971 4 8865465

Asia-Pacific:

Emerson Automation Solutions
Remote Automation Solutions
1 Pandan Crescent
Singapore 128461
T +65 6777 8211 | F +65 6777 0947

© 2018 Remote Automation Solutions, a business unit of Emerson Automation Solutions. All rights reserved.

This publication is for informational purposes only. While every effort has been made to ensure accuracy, this publication shall not be read to include any warranty or guarantee, express or implied, including as regards the products or services described or their use or applicability. Remote Automation Solutions (RAS) reserves the right to modify or improve the designs or specifications of its products at any time without notice. All sales are governed by RAS terms and conditions which are available upon request. RAS accepts no responsibility for proper selection, use or maintenance of any product, which remains solely with the purchaser and/or end-user.