

ControlWave Redundant I/O And Communications Switch Unit

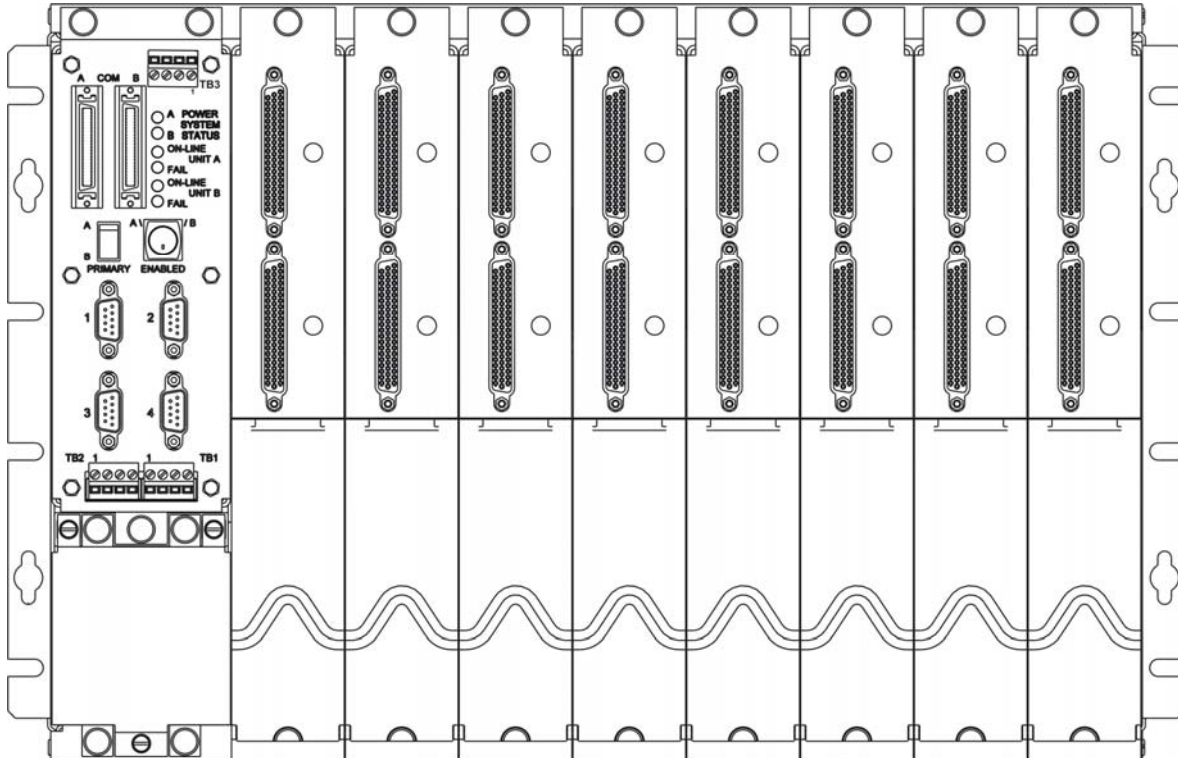

ControlWave

IMPORTANT! READ INSTRUCTIONS BEFORE STARTING!

Be sure that these instructions are carefully read and understood before any operation is attempted. Improper use of this device in some applications may result in damage or injury. The user is urged to keep this book filed in a convenient location for future reference.

These instructions may not cover all details or variations in equipment or cover every possible situation to be met in connection with installation, operation or maintenance. Should problems arise that are not covered sufficiently in the text, the purchaser is advised to contact Emerson Process Management, Remote Automation Solutions division (RAS) for further information.

EQUIPMENT APPLICATION WARNING

The customer should note that a failure of this instrument or system, for whatever reason, may leave an operating process without protection. Depending upon the application, this could result in possible damage to property or injury to persons. It is suggested that the purchaser review the need for additional backup equipment or provide alternate means of protection such as alarm devices, output limiting, fail-safe valves, relief valves, emergency shutoffs, emergency switches, etc. If additional information is required, the purchaser is advised to contact RAS.

RETURNED EQUIPMENT WARNING

When returning any equipment to RAS for repairs or evaluation, please note the following: The party sending such materials is responsible to ensure that the materials returned to RAS are clean to safe levels, as such levels are defined and/or determined by applicable federal, state and/or local law regulations or codes. Such party agrees to indemnify RAS and save RAS harmless from any liability or damage which RAS may incur or suffer due to such party's failure to so act.

ELECTRICAL GROUNDING

Metal enclosures and exposed metal parts of electrical instruments must be grounded in accordance with OSHA rules and regulations pertaining to "Design Safety Standards for Electrical Systems," 29 CFR, Part 1910, Subpart S, dated: April 16, 1981 (OSHA rulings are in agreement with the National Electrical Code).

The grounding requirement is also applicable to mechanical or pneumatic instruments that include electrically operated devices such as lights, switches, relays, alarms, or chart drives.

EQUIPMENT DAMAGE FROM ELECTROSTATIC DISCHARGE VOLTAGE

This product contains sensitive electronic components that can be damaged by exposure to an electrostatic discharge (ESD) voltage. Depending on the magnitude and duration of the ESD, this can result in erratic operation or complete failure of the equipment. Read supplemental document S14006 at the back of this manual for proper care and handling of ESD-sensitive components.

Remote Automation Solutions

A Division of Emerson Process Management
1100 Buckingham Street, Watertown, CT 06795
Telephone (860) 945-2200

WARRANTY

- A. Remote Automation Solutions (RAS) warrants that goods described herein and manufactured by RAS are free from defects in material and workmanship for one year from the date of shipment unless otherwise agreed to by RAS in writing.
- B. RAS warrants that goods repaired by it pursuant to the warranty are free from defects in material and workmanship for a period to the end of the original warranty or ninety (90) days from the date of delivery of repaired goods, whichever is longer.
- C. Warranties on goods sold by, but not manufactured by RAS are expressly limited to the terms of the warranties given by the manufacturer of such goods.
- D. All warranties are terminated in the event that the goods or systems or any part thereof are (i) misused, abused or otherwise damaged, (ii) repaired, altered or modified without RAS consent, (iii) not installed, maintained and operated in strict compliance with instructions furnished by RAS or (iv) worn, injured or damaged from abnormal or abusive use in service time.
- E. These warranties are expressly in lieu of all other warranties express or implied (including without limitation warranties as to merchantability and fitness for a particular purpose), and no warranties, express or implied, nor any representations, promises, or statements have been made by RAS unless endorsed herein in writing. Further, there are no warranties which extend beyond the description of the face hereof.
- F. No agent of RAS is authorized to assume any liability for it or to make any written or oral warranties beyond those set forth herein.

REMEDIES

- A. Buyer's sole remedy for breach of any warranty is limited exclusively to repair or replacement without cost to Buyer of any goods or parts found by Seller to be defective if Buyer notifies RAS in writing of the alleged defect within ten (10) days of discovery of the alleged defect and within the warranty period stated above, and if the Buyer returns such goods to the RAS Watertown office, unless the RAS Watertown office designates a different location, transportation prepaid, within thirty (30) days of the sending of such notification and which upon examination by RAS proves to be defective in material and workmanship. RAS is not responsible for any costs of removal, dismantling or reinstallation of allegedly defective or defective goods. If a Buyer does not wish to ship the product back to RAS, the Buyer can arrange to have a RAS service person come to the site. The Service person's transportation time and expenses will be for the account of the Buyer. However, labor for warranty work during normal working hours is not chargeable.
- B. Under no circumstances will RAS be liable for incidental or consequential damages resulting from breach of any agreement relating to items included in this quotation from use of the information herein or from the purchase or use by Buyer, its employees or other parties of goods sold under said agreement.

How to return material for Repair or Exchange

Before a product can be returned to Remote Automation Solutions (RAS) for repair, upgrade, exchange, or to verify proper operation, Form (GBU 13.01) must be completed in order to obtain a RA (Return Authorization) number and thus ensure an optimal lead time. Completing the form is very important since the information permits the RAS Watertown Repair Dept. to effectively and efficiently process the repair order.

You can easily obtain a RA number by:

A. FAX

Completing the form (GBU 13.01) and faxing it to (860) 945-2220. A RAS Repair Dept. representative will return the call (or other requested method) with a RA number.

B. E-MAIL

Accessing the form (GBU 13.01) via the RAS Web site (www.emersonprocess.com/Bristol) and sending it via E-Mail to Custserve.bristol@emersonprocess.com . A RAS Repair Dept. representative will return E-Mail (or other requested method) with a RA number.

C. Mail

Mail the form (GBU 13.01) to

Remote Automation Solutions
A Division of Emerson Process Management
Repair Dept.
1100 Buckingham Street
Watertown, CT 06795

A RAS Repair Dept. representative will return call (or other requested method) with a RA number.

D. Phone

Calling the RAS Repair Department at (860) 945-2442. A RAS Repair Department representative will record a RA number on the form and complete Part I, send the form to the Customer via fax (or other requested method) for Customer completion of Parts II & III.

A copy of the completed Repair Authorization Form with issued RA number should be included with the product being returned. This will allow us to quickly track, repair, and return your product to you.



Remote Automation Solutions (RAS)

Repair Authorization Form (on-line completion)

(Providing this information will permit Bristol, also doing business as Remote Automation Solutions (RAS) to effectively and efficiently process your return. Completion is required to receive optimal lead time. Lack of information may result in increased lead times.)

Date **RA #** **SH** **Line No.**

Standard Repair Practice is as follows: Variations to this is practice may be requested in the "Special Requests" section.

- Evaluate / Test / Verify Discrepancy
- Repair / Replace / etc. in accordance with this form
- Return to Customer

Please be aware of the Non warranty standard charge:

- There is a \$100 minimum evaluation charge, which is applied to the repair if applicable (✓ in "returned" B,C, or D of part III below)

Part I Please complete the following information for single unit or multiple unit returns

Address No. _____ (office use only)

Bill to :

Ship to:

Purchase Order:

Contact Name:

Phone:

Fax:

E-Mail:

Part II Please complete Parts II & III for each unit returned

Model No./Part No. **Description:**

Range/Calibration: **S/N:**

Reason for return : Failure Upgrade Verify Operation Other

1. Describe the conditions of the failure (Frequency/Intermittent, Physical Damage, Environmental Conditions, Communication, CPU watchdog, etc.) (Attach a separate sheet if necessary)
2. Comm. interface used: Standalone RS-485 Ethernet Modem (PLM (2W or 4W) or SNW) Other:
3. What is the **Firmware** revision? What is the **Software** & version?

Part III If checking "replaced" for any question below, check an alternate option if replacement is not available

- A. If product is within the warranty time period but is excluded due to the terms of warranty,, would you like the product: repaired returned replaced scrapped?
- B. If product were found to exceed the warranty period, would you like the product: repaired returned replaced scrapped?
- C. If product is deemed not repairable would you like your product: returned replaced scrapped?
- D. If RAS is unable to verify the discrepancy, would you like the product: returned replaced *see below?

* Continue investigating by contacting the customer to learn more about the problem experienced? The person to contact that has the most knowledge of the problem is: phone

If we are unable to contact this person the backup person is: phone

Special Requests:

Ship prepaid to: Remote Automation Solutions, Repair Dept., 1100 Buckingham Street, Watertown, CT 06795
Phone: 860-945-2442 Fax: 860-945-2220

Emerson Process Management *Training*

GET THE MOST FROM YOUR EMERSON INSTRUMENT OR SYSTEM

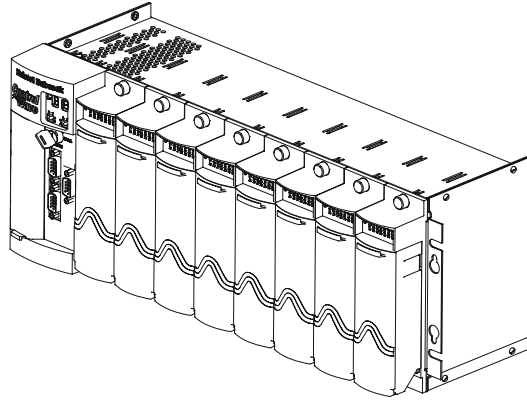

- Avoid Delays and problems in getting your system on-line
- Minimize installation, start-up and maintenance costs.
- Make the most effective use of our hardware and software.
- Know your system.

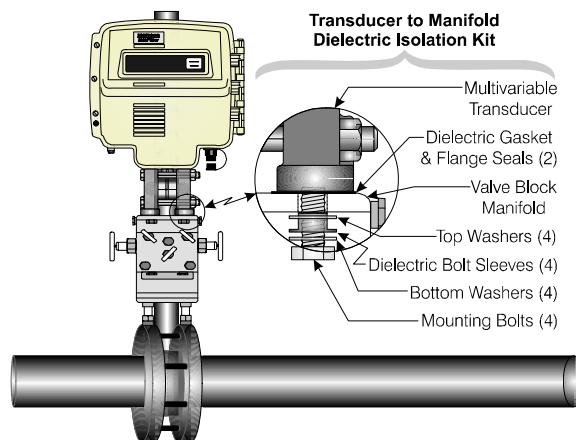

As you know, a well-trained staff is essential to your operation. Emerson offers a full schedule of classes conducted by full-time, professional instructors. Classes are offered throughout the year at various locations. By participating in our training, your personnel can learn how to install, calibrate, configure, program and maintain your Emerson products and realize the full potential of your system.

For information or to enroll in any class, go to <http://www.EmersonProcess.com/Remote> and click on "Training" or contact our training department in Watertown at (860) 945-2343.

CI-ControlWaveREDIO

ControlWave Redundant I/O and Communications Switch Unit

TABLE OF CONTENTS

<i>SECTION</i>	<i>TITLE</i>	<i>PAGE #</i>
Section 1 - INTRODUCTION		
1.1	GENERAL INTRODUCTION.....	1-1
1.2	REDUNDANCY CONCEPTUALLY.....	1-1
1.2.1	Redundant System Operation.....	1-2
1.3	THEORY OF OPERATION	1-4
1.3.1	IORC Module Function	1-5
1.3.1.1	IORCM Functionality Overview	1-6
1.3.1.2	IORCM Module Functional Details.....	1-6
1.3.2	CWREDIO Power System	1-8
1.3.3	CWREDIO IORCM Control Logic.....	1-8
1.3.3.1	IORCM LED Status Display Indicators.....	1-9
1.3.3.2	CWREDIO IORCM Online Relays.....	1-9
1.3.3.3	Serial Communication Ports.....	1-9
1.3.3.4	Watchdog Inputs.....	1-10
1.4	GENERAL DESCRIPTION	1-10
1.4.1	Overview of Local I/O and I/O Expansion Rack Redundancy Control Systems.....	1-11
1.4.1.1	Overview of the Local I/O Redundancy Control Systems.....	1-11
1.4.1.2	Overview of the I/O Expansion Rack Redundancy Control Systems.....	1-11
1.4.2	Overview of the ControlWave Redundant I/O and Comm. Switch Unit	1-14
1.4.3	Key System Features.....	1-14
1.5	PHYSICAL DESCRIPTION.....	1-14
1.5.1	Chassis Assembly	1-15
1.5.2	I/O Redundancy Backplane Assembly (IORB)	1-15
1.5.3	Power Supply/Monitor Modules (PSMM).....	1-17
1.5.3.1	PSMM Power Switch SW1	1-17
1.5.3.2	PSMM Board Fuse F1	1-18
1.5.3.3	PSMM Board Connectors	1-18
1.5.3.4	PSMM LED	1-18
1.5.4	I/O Redundancy Control Module (IORCM)	1-18
1.5.4.1	I/O Redundancy Control Module Connectors.....	1-19
1.5.4.2	I/O Redundancy Control Module Switches	1-20
1.5.4.3	I/O Redundancy Control Module LEDs	1-21
1.5.5	I/O Redundancy Switch Modules (IORSM).....	1-21
1.5.5.1	I/O Redundancy Switch Module Connectors.....	1-23
1.5.5.2	Associated ControlWave I/O Modules.....	1-24
Section 2 - INSTALLATION & OPERATION		
2.1	INSTALLATION IN HAZARDOUS AREAS.....	2-1
2.2	CWREDIO INSTALLATION SITE CONSIDERATIONS.....	2-2
2.2.1	Temperature & Humidity Limits	2-2
2.2.2	Vibration Limits	2-2
2.3	CWREDIO INSTALLATION/CONFIGURATION	2-2
2.3.1	Mounting ControlWave Redundant I/O and Comm. Switch Units.....	2-5

CI-ControlWaveREDIO

ControlWave Redundant I/O and Communications Switch Unit

TABLE OF CONTENTS

<i>SECTION</i>	<i>TITLE</i>	<i>PAGE #</i>
Section 2 - INSTALLATION (Continued)		
2.3.1.1	CWREDIO Grounding	2-5
2.3.1.2	Communication Ports	2-5
2.3.1.3	RS-232 & RS-485 Interfaces	2-6
2.3.2	I/O Redundancy Switch Module Installation & Wiring	2-11
2.3.2.1	Installation of I/O Redundancy Switch Modules	2-11
2.3.2.2	Wire Connections	2-15
2.3.2.3	Shielding and Grounding	2-15
2.3.2.4	Digital Inputs	2-16
2.3.2.4.1	Digital Input Configurations	2-17
2.3.2.5	Digital Outputs	2-20
2.3.2.5.1	Digital Output Configurations	2-20
2.3.2.6	Analog Inputs	2-24
2.3.2.6.1	Analog Input Configurations	2-25
2.3.2.7	Analog Outputs	2-26
2.3.2.7.1	Analog Output Configurations	2-27
2.3.2.8	Universal Digital Input Modules	2-29
2.3.2.8.1	Universal Digital Input Configurations	2-30
2.3.3	Power Supply Wiring	2-32
2.3.3.1	Bulk Power Supply Current Requirements	2-32
2.3.3.2	Power Wiring	2-34
2.3.3.3	Redundancy Control Field Wiring	2-34
2.3.4	PSMM Cover	2-36
2.4	OPERATIONAL DETAILS	2-36
2.4.1	Operation of IORC Module Switches	2-36
2.4.1.1	SW1 - Key Operated A/B ENABLE Mode Switch	2-36
2.4.1.2	SW2 - A/B Primary Controller Select Switch	2-36
2.4.1.3	Forcing a Fail-over to the BACKUP (Standby) Unit via Program Control	2-36
2.4.1.4	Manually Forcing a Fail-over to the BACKUP (Standby) Unit	2-38
2.4.2	ControlWave Soft Switch Configuration and Communication Ports	2-38
Section 3 – SERVICE		
3.1	SERVICE INTRODUCTION	3-1
3.2	COMPONENT REMOVAL/REPLACEMENT PROCEDURES	3-1
3.2.1	Accessing Modules for Testing	3-1
3.2.2	Removal/Replacement of the I/O Redundancy Control Module	3-2
3.2.3	Removal/Replacement of a Power Supply/Monitor Module	3-2
3.2.4	Removal/Replacement of a I/O Redundancy Switch Module	3-2
3.3	TROUBLESHOOTING TIPS	3-3
3.3.1	Power Supply/Monitor Module (PSMM) Voltage Checks	3-3
3.3.2	LED Checks	3-4
3.3.3	Wiring/Signal Checks	3-9
3.4	GENERAL SERVICE NOTES	3-9

CI-ControlWaveREDIO

ControlWave Redundant I/O and Communications Switch Unit

TABLE OF CONTENTS

<i>SECTION</i>	<i>TITLE</i>	<i>PAGE #</i>
Section 3 – SERVICE (Continued)		
3.4.1	Extent of Field Repairs.....	3-9
3.5	WINDIAG DIAGNOSTICS	3-10
3.5.1	Diagnostics Using WINDIAG	3-13
3.5.1.1	Communications Diagnostic Port Loop-back Test.....	3-13
3.5.1.2	COM 1, 2, 3, 4 External Loop-back Test Procedure.....	3-15
3.6	TROUBLESHOOTING REDUNDANCY PROBLEMS	3-16
3.7	ControlWaveREDIO FUNCTIONAL TESTS	3-17
3.7.1	Basic Reset and Supervisory Power-Up Tests	3-18
3.7.2	Redundant Power Source & Supervisory Power-Up Tests	3-18
3.7.3	Watchdog Mechanism Power-Up Tests	3-18
3.7.4	Primary CPU Selection on Power-Up Tests.....	3-19
3.7.5	Tests of Switchover from “Dead” Primary Selected Unit on Power-Up	3-19
3.7.6	Forced Primary CPU Selection on Power-Up Tests	3-20
3.7.7	Normal Power-Up & Switchover Tests.....	3-21
3.7.8	Normal Power-Up & Forced Switchover Tests	3-22
3.7.9	On-Line Relay Functional Tests	3-22
3.7.10	I/O Redundancy Control Module Comm. Ports Functional Tests.....	3-23
3.7.10.1	Configuration for Port Tests	3-23
3.7.10.2	Communication Port Switching Tests	3-24

Section 4 - SPECIFICATIONS

4.1	ControlWave I/O REDUNDANCY CONTROL MODULE	4-1
4.1.1	I/O Redundancy Control Module General Specifications	4-1
4.2	POWER SUPPLY/MONITOR MODULE	4-3
4.2.1	Input Power Specs.	4-3
4.2.2	Power Supply/Monitor Specs.	4-3
4.2.3	Power Supply Input Connector	4-3
4.3	BACKPLANE PCB	4-4
4.4	ENVIRONMENTAL SPECIFICATIONS	4-5
4.5	DIMENSIONS	4-5

APPENDICES/SUPPLEMENTAL INSTRUCTION

Site Considerations for Equipment Installation, Grounding & Wiring	S1400CW
Care and Handling of PC Boards and ESD-Sensitive Components	S14006

REFERENCED BBI CUSTOMER INSTRUCTION MANUALS

ControlWave Process Automation Controller Instruction Manual.....	CI-ControlWave
ControlWave I/O Expansion Rack Instruction Manual.....	CI-ControlWaveEXP
WINDIAG - Windows Diagnostics for BBI Controllers	D4041A
Open BSI Utilities Manual	D5081

CI-ControlWaveREDIO

ControlWave Redundant I/O and Communications Switch Unit

TABLE OF CONTENTS

REFERENCED BBI CUSTOMER SERVICE MANUALS (Continued)

ControlWave Quick Setup Guide	D5084
Getting Started with ControlWave Designer	D5085
Web_BSI Manual	D5087
ControlWave Redundancy Setup Guide	D5123
ControlWave Designer Programmer's Handbook	D5125

Section 1

INTRODUCTION

1.1 GENERAL INTRODUCTION

This chapter provides an introduction and overview of the **ControlWave®** Redundant I/O and Communications Switch Unit and redundant systems. The concept of redundancy, theory of operation and general component/system description and physical component descriptions are provided herein.

1.2 REDUNDANCY CONCEPTUALLY

Redundancy is a mechanism employed to prevent the loss of control over a process, and minimize the loss of data, which can occur, if the **ControlWave** Controller should fail. It is accomplished by using the **ControlWave** Redundant I/O and Communications Switch Unit (CWREDIO). Redundancy is recommended for plants or processes where a loss of control could result in damage, injury, or loss of production capability.

A **ControlWave** Redundant I/O and Comm. Switch Unit (CWREDIO) interfaces a pair of **ControlWave** Process Automation Controllers or **ControlWave** I/O Expansion Racks (which are identical except for CPU configuration switch settings and unique IP addresses). The CWREDIO unit is housed in its own stainless steel chassis and utilizes an I/O Redundancy Control Module (IORCM) to interface and switch process control between CW_A/CWEXP_A and CW_B/CWEXP_B units.

Note: For the sake of simplicity the term CW will be used herein to mean either a ControlWave or a ControlWave I/O Expansion Rack.

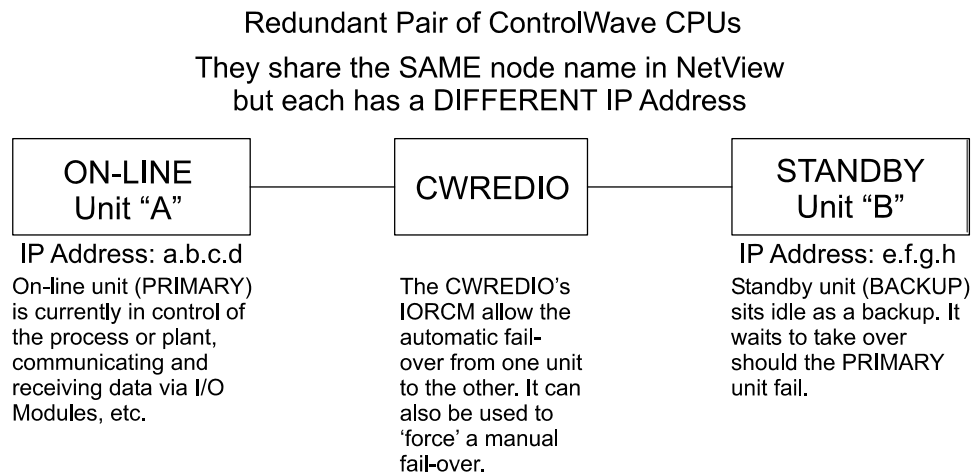

Figure 1-1 - Basic Redundancy Conceptual Diagram

I/O Redundancy Control Modules select one of the redundant CW units to serve as the **PRIMARY** Controller while the other is selected as the hot **BACKUP** Controller. Although field inputs (AIs, DIs and UDIs) are present at CW_A and CW_B, it is the **PRIMARY** Controller that receives them and controls field outputs (AOs and DOs). The **BACKUP** Controller is updated via a **side-load** from the **PRIMARY** Controller with historic, configuration and process I/O data.

The IORCM switches set control of the process and up to four communication ports from one CW unit to the other in the event the unit (CW_A or CW_B) designated the **PRIMARY** detects a failure and watchdogs. The process of transferring control from one CW unit to the other is referred to as **fail-over**. A fail-over from one CPU to the other typically falls into one of two categories:

Hardware failures - These could occur from a variety of causes:

- A loose cable
- Improper configuration, e.g. CW_A/CW_B board not seated properly
- Power supply failure at CW_A/CW_B (no power for CPU)
- Individual board or component breakdown at CW_A/CW_B

Software failures - Possible causes include:

- Application program running in the **PRIMARY** CPU 'crashes', as indicated by an 'FF' code on the display
- All tasks at the **PRIMARY** are suspended for more than a user-configurable number of milliseconds
- A task watchdog occurs (this option can be user enabled/disabled)
- User-created logic for detection of a particular failure is activated, triggering a switchover via a REDUN_SWITCH function block

These sorts of failures trigger a Watchdog Relay, and cause a fail-over from the **PRIMARY** CW unit to the **BACKUP** CW unit. The **BACKUP** CW unit has been configured to be a nearly exact duplicate of the **PRIMARY** CW unit, so it can assume full control over the process when it becomes the *new PRIMARY*, i.e., the on-line CW unit.

ControlWave redundancy only handles a single point of failure i.e. either the "A" CW unit can have a failure, or the "B" CW unit can have a failure. A failure of the "A" CPU, and the "B" power supply, however, would disable the entire **ControlWave** Redundant I/O system, even though the CWREDIO unit may be completely operational.

1.2.1 Redundant System Operation

Whenever the **PRIMARY** (on-line) **ControlWave** CPU receives a download of a new **ControlWave** project file (boot project), that project is immediately transmitted to the **BACKUP** (standby) **ControlWave** unit, and stored. This is known as a **side-load**. The boot project is loaded into memory in the **BACKUP** CW unit but kept in the 'Stopped' state. A side-load also occurs at the initial startup of the **BACKUP** CW unit. Side-loads typically occurs via Ethernet communications. It is not recommended to use RS-232 or RS-485 Ports for this process.

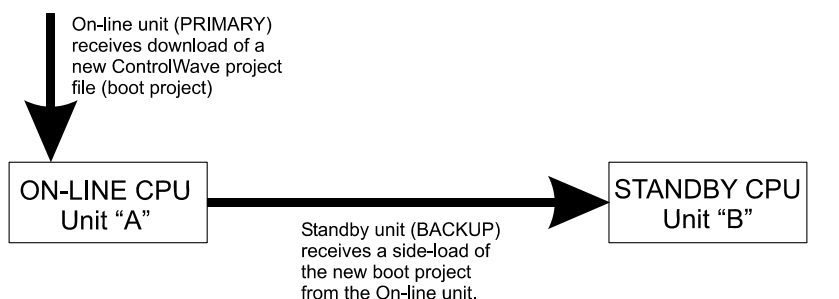

Figure 1-2 - Redundant CW Side-load Diagram

The **PRIMARY ControlWave** CPU is the only unit executing the project, communicating with I/O boards and controlling the plant or process. The **BACKUP ControlWave's** CPU sits idle except for receiving updates from the on-line unit.

The updates from the **PRIMARY** unit to the **BACKUP** unit occur at the end of each task execution cycle, unless:

- There have been no changes to process I/O output variables *-and-*
- The minimum update time¹ has not expired

1 The minimum update time is a configured value that may be used to limit the amount of traffic between the on-line unit and the standby unit. Every time an update occurs the minimum update timer is restarted. Unless process I/O output changes occur, any changes occurring during the time prior to expiration of the configured update timer will not trigger an update to the standby unit. Instead, they will be held until expiration of the timer, and the end of a task execution cycle. The timer value is set via the `_RDN_MIN_UPD` system variable.

Updates between the **PRIMARY** unit, and the **BACKUP** unit, may consist of multiple update messages, followed by a 'commit' message. Until the commit message is received, the update messages are not applied to the **BACKUP** unit. This ensures that if the **PRIMARY** unit fails before it sends the 'commit' message, that a partial update, e.g. incomplete data, is not used. Instead, the **BACKUP** will discard the incomplete update data, and start up using the last complete update that ended with a commit message.

In general, data is only transferred from the **PRIMARY** unit to the **BACKUP** unit if it has changed. Among the types of data transferred are:

- Any changed process I/O variables
- All variables marked as RETAIN in the user's project
- Any data in the static memory area (begins at address 3.100000)
- Certain function block parameters that are retained
- Changes to certain port configuration information, e.g., on-line baud rate changes, etc.
- Changes to user account definitions (usernames, passwords)
- Any newly generated alarms plus any changed alarm states from alarm function blocks
- Historical data (audit records, archive files)

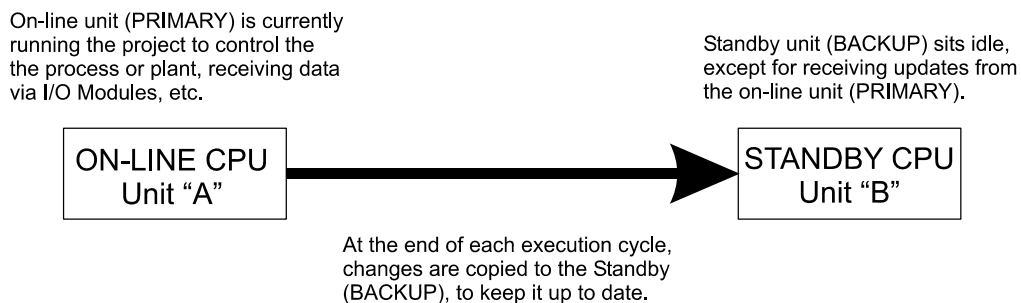

Figure 1-3 - PRIMARY vs BACKUP CW Diagram

If a failure occurs at the **PRIMARY** unit, a Watchdog Relay is triggered, and the CWREDIO's I/O Redundancy Control Module (IORCM) will switch control to the **BACKUP** CW's CPU. The **BACKUP** CW now becomes the *new* on-line unit, i.e., the **PRIMARY**.

Note: Manually forced and program controlled fail-over are discussed in Chapter 2 – Section 2.4.1.

1.3 THEORY OF OPERATION

ControlWave Redundant I/O and Communications Switch Units (CWREDIO) interface to two identical **ControlWave** (CW) Process Automation Controllers or two identical **ControlWave** I/O Expansion Racks (CWEXP) to form a redundant control system. In this system, one of the CWs or CWEXPs serves as the **PRIMARY** Controller and the other serves as an automatically or manually switched **BACKUP** Controller that gets switched over in the event of hardware failure or power loss at the **PRIMARY**.

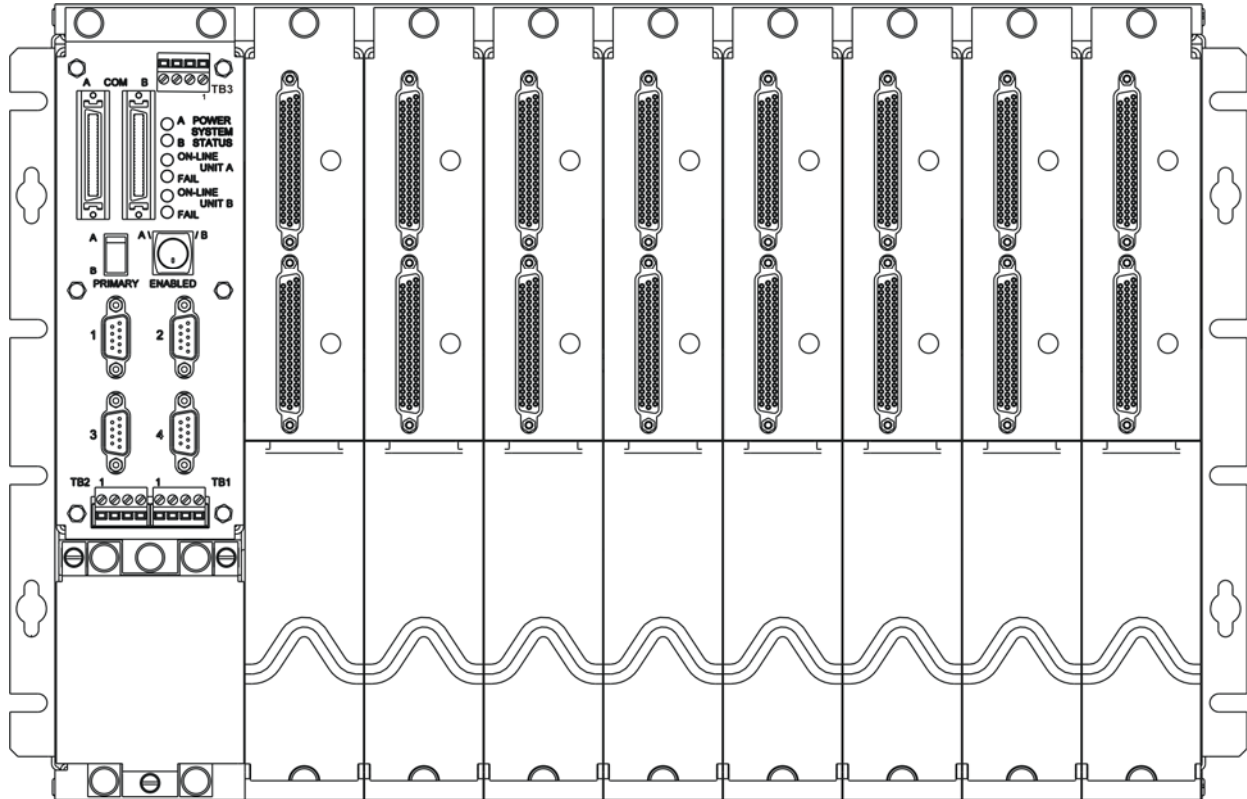

Figure 1-4 ControlWave Redundant I/O and Communications Switch Unit

CWREDIOs consists of a Chassis with Backplane PCB, two Power Supply/Monitor Modules (PSSM), an I/O Redundancy Control Module (IORCM) and from 1 to 8 I/O Redundancy Switch Modules (IORSM). Operator interface for setup and control of the redundant system is provided by the IORCM.

Note: From herein the term CW will imply ControlWave or ControlWave I/O Expansion Rack.

CWREDIO's I/O Redundancy Control Module circuitry provides the following system functions:

- Operator Interface
- Automatic or Manual selection (switching) of the **PRIMARY** Controller
- Switching of serial communication ports 1 through 4 (associated with the selected **PRIMARY** Controller of the pair)
- Switching of the output points of the various Output Modules (associated with the selected **PRIMARY** Controller) to field terminations on matching I/O Redundancy Switch Modules (IORSM) resident in the CWREDIO. **Note: Field inputs are not switched, but rather are supplied to both the PRIMARY and BACKUP CWs.**

1.3.1 IORCM Function

Front panel user interface, module/system status indicators and interconnections/switching for serial communications from the selected **PRIMARY** CW serial communication ports to CWREDIO front panel mounted field-accessed connectors are implemented by the IORCM. Custom cabling provides I/O interface between each IORSM and Remotely Terminated I/O Modules on the external CWs (**PRIMARY** and **BACKUP**). Process inputs (AI, DI, UDI) are supplied to both the **PRIMARY** and **BACKUP** CWs and are never switched. Process outputs are automatically switched from the selected CW unit at the IORSMs via IORCM control.

Redundant circuitry is implemented to increase the reliability of the IORCM control logic. Items not included in this implementation, or external signals or components that are not part of this category are: external input/output signals, interface power (for display LEDs, solid state relays, etc), relays and relay contacts, outputs of the voting circuitry and interconnects.

Triple replicated system logic blocks and multiple logic power sources are used to provide a high level of tolerance to miscellaneous hardware faults. The logic blocks monitor CW unit status (CW watchdog signals), CWIORC module front panel settings (mode and primary controller select switches) and internal control logic states, and generate on-line control signals for both (redundant) external CW units.

The IORB implements system interconnections between the CWREDIO's two Power Supply Monitor Modules (PSMM), control logic on the IORC and IORS Modules. Separate logic and relay power connections (+5.2Vdc (logic), +5.2Vdc (relay) from the same PSMM output source are taken from each PSMM slot and carried to the IORCM slot. IORCM hardware combines the sources to generate redundant logic (VCC_RED) and relay power (RED_RLY_PWR) via *ORing* diodes, and passes these redundant sources through the IORB for routing to all eight (8) IORSM slots. IORCM hardware also generates redundant A/B system select signals (A/B I/O selection control), which are also routed through the IORB for passage to all IORSM slots. **Note: Logic power, relay power and A/B select signals are only utilized by output version IORS Modules. An IORC Module also uses relays to switch serial communication ports between the field and the selected PRIMARY controller, i.e., CW_A or CW_B.**

Two CWREDIO Control Panel Switches determine I/O redundancy modes of operation. The key operated A/B ENABLE Mode Selection Switch selects one of three operating modes: [FORCE] A, [AUTO SELECT] ENABLED or [FORCE] B. With this switch in [FORCE] A position, all IORS output type modules are instructed to switch CW_A outputs to IORSM mounted field terminations (regardless of CW_A watchdog signal status or IORCM logic state). CW_B outputs are switched in a similar manner if this switch is in [FORCE] B position. In [AUTO SELECT] ENABLED position, the source of I/O is based upon the current online controller, which is selected according to logic algorithms embedded within the IORC Module. The A/B Primary Selection Switch (**examined at power up, only**) selects either CW_A or CW_B as **PRIMARY** Controller if the respective CW unit is ready for on-line operation, i.e., corresponding watchdog signal is high (+24V), and the key operated A/B Enabled Mode Selection Switch is in the ENABLED position.

1.3.1.1 IORCM Functionality Overview

1. Automatically selects the external CW_A or CW_B units for **PRIMARY** and **BACKUP** operation. Control is achieved based on the status of the watchdog signal cabled in from each unit and control logic implemented within the IORC Module. Automatic CW selection is prioritized based on the IORCM's A/B PRIMARY Switch (at power up, only) and the key operated A/B ENABLE Mode Selection Switch (when in the ENABLED position only).
2. Forces selection of CW_A or CW_B as **PRIMARY** for control, based on the IORCM's key operated A/B ENABLE Mode Selection Switch when it is in the A or B positions respectively (i.e. ignores the current watchdog state of the selected CW unit).
3. Generates individual external A_ONLINE and B_ONLINE control signals (as isolated relay contact outputs) for the respective CW units. These signals are cabled to each CW unit and select the **PRIMARY** Controller (i.e. the CW unit that is authorized to control I/O and external communications).
4. Implements triple redundant voting circuits that select the **PRIMARY** CW unit based on the criteria discussed in (1), (2) and (3) above (i.e. based on CW_A and CW_B watchdog status, user controls and IORC Module algorithms).
5. Displays the status of the external CW_A and CW_B watchdog inputs.
6. Displays which CW unit is selected.
7. Displays the status of the triple redundant voting circuit power supplies, as well as that of the non-voting logic supply and external redundant logic power and relay power sources.
8. Guarantees single point fault tolerance on internal signals, power supplies and circuitry to as great a degree as possible. Signals excluded from this category are external watchdog signals.

1.3.1.2 IORCM Functional Details

Redundant circuitry is implemented to increase the reliability of the CWIORC control logic. Items not included in this implementation, or external signals or components that are not be part of this category are: external input/output signals, interface power (for display LEDs, relay drivers, etc), relays and relay contacts, selector switches, outputs of the voting circuitry, LED indicators and interconnects.

Determination of on-line and failure status for both external redundant CW units is performed by triple replicated programmable logic devices whose outputs feed 2 of 3 majority voting blocks. The status determination of all 3 programmable logic blocks is examined by majority voting logic, which generates final on-line and failure status signals based on the two logic blocks in agreement. The majority voting logic adds fault tolerance to the process by allowing for hardware failure in one of the determining logic blocks.

Multiple logic power sources are used to provide a high level of tolerance to miscellaneous hardware faults. All IORCM hardware, except communication port switching relay coils, are powered by multiple power supplies that generate +3.3Vdc. Three voltage regulators generate +3.3Vdc sources that supply independent power to each of the system

programmable logic blocks. An additional regulator, supplies most of the remaining board hardware, and a fifth +3.3Vdc source is utilized to power IORCM front panel LED indicators and supply supervisors. In the event of a fault condition, the circuit arrangement prevents the offending source from taking down the remaining IORCM sources. A pair of power supply monitors, also drive their respective power status LED's, on the front panel to indicate a failure in one of the supply groups.

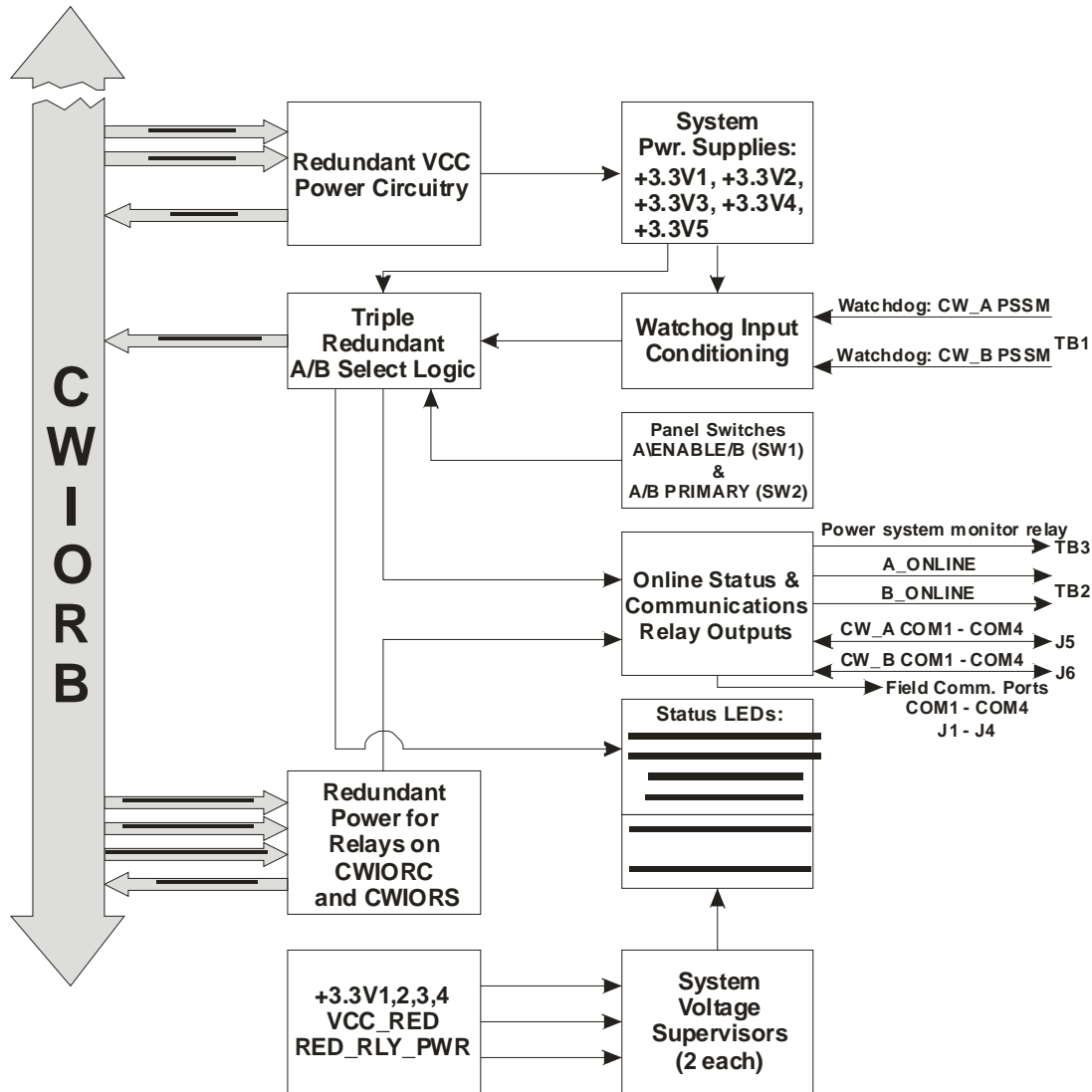

Figure 1-5 - Block Diagram - CWREDIO I/O Redundancy Control Module

Input power to each IORCM +3.3Vdc supply group is derived by combining 2ea +5.2Vdc logic sources via an independent set of ORing diodes (one set per +3.3Vdc group) for redundancy reasons. These sources are generated by dual redundant power supplies (PSMM) that are plugged into the system backplane (IORB).

The IORC Module is implemented as a front panel board and Logic/Power Supply Board set that is interfaced to each other via complementary high reliability connectors.

1.3.2 CWREDIO Power System

The +5.2Vdc and relay supply voltages of the dual PSMM modules plugged into the IORB are redundantly combined via *ORing* diodes on the IORC Module's Logic Board to generate VCC_RED and RED_RLY_PWR sources respectively. VCC_RED supplies transistor logic on the IORC and IORS modules, and provides input voltage to the five, +3.3Vdc logic power supplies located on the IORC Module's Logic Board. Supplies +3.3V1, +3.3V2 & +3.3V3 power the triple redundant voting blocks. The +3.3V4 & +3.3V5 supplies power general logic and LED indicators/voltage supervisors respectively. Each +3.3Vdc supply has an input thermal switch to shutdown its circuit under fault conditions. Redundant source RED_RLY_PWR powers communication and on-line status relays on the IORC Module's Logic Board, and relay circuits on output type IORS Modules.

1.3.3 CWREDIO IORCM Control Logic

Determination of on-line and failure status for both external redundant CW units is performed by triple replicated programmable logic devices whose outputs feed 2 of 3 majority voting blocks. The majority voting logic adds fault tolerance to the process by allowing for hardware failure in one of the determining logic blocks. Each programmable logic device block monitors external CW status (via connected CW watchdog output signals WDG_A, WDG_B), IORC Module front panel settings (A/B Enable Mode and Primary Controller Select Switches) and internal logic states, and generates on-line control outputs (via signals A_ONLINE and B_ONLINE) for both redundant CW units.

Watchdog hardware on the external CW units, from respective CPU through special I/O Redundancy Power Supply Sequencer Modules (IORED-PSSM), source their status to IORC Module logic with +24Vdc level signals WDG_A and WDG_B via front panel terminal block TB1. IORC Module logic returns back to each CW unit its on-line control command with signals A_ONLINE and B_ONLINE via isolated relay contacts closures on front panel terminal block TB2. In the event of IORCM logic power failure, A_ONLINE will be active (on-line state/contact closed), while B_ONLINE will be inactive (backup state/contact open).

Two control panel switches determine I/O redundancy modes of operation. Key operated A/B ENABLE Mode Switch selects one of three operating modes: [FORCE] A, [AUTO SELECT] ENABLED or [FORCE] B. With this switch in [FORCE] A position, all CWIORS output type modules are instructed to switch CW_A outputs to IORSM mounted field terminations (regardless of CW_A watchdog signal status or IORCM logic state). CW_A serial communication ports are also be switched to the front panel ports on the IORCM. CW_B outputs and ports are switched in a similar manner if this switch is in [FORCE] B position. In [AUTO SELECT] ENABLED position, the source of I/O is based upon the current online (**PRIMARY**) Controller, external system watchdog status and logic algorithms embedded within the IORC Module. The A/B PRIMARY Controller Select Switch (**examined at power up, only**) selects either CW_A or CW_B as **PRIMARY** if the respective CW unit is ready for on-line operation (i.e., corresponding watchdog signal is high (+24V / WDOG OK)), and the A/B ENABLE Mode Select Switch is in the ENABLED position.

The alternate (**BACKUP**) CW system is selected if the **PRIMARY** CW system fails (its watchdog signal becomes low (0V/ WDOG FAILURE) and the alternate system is available (its watchdog signal is high). Once selected, the alternate CW becomes **PRIMARY** and remain selected (regardless of the state of the other CW unit) unless its watchdog changes to failed status, and the A/B ENABLE Mode Switch is in the ENABLED position.

IORCM control logic sets redundant signals A/BSEL1, A/BSEL2 & A/BSEL3 active ('1': high) - based on the criteria discussed above) to cause all IORSM output type modules to switch CW_A outputs to their respective IORSM terminations. Conversely, CW_B outputs are switched if the select signals are inactive ('0': low). These select signals are processed by 2 of 3 voting circuits on the IORS Modules to insure fault tolerance.

1.3.3.1 IORCM LED Status Display Indicators (see Figure 1-10 and Table 1-2)

Six LED indicators are viewable on the front panel of the IORC module. These status indicators are powered from an additional independent +3.3Vdc power source on the logic board (+3.3V5), and display the status of the external CW racks under IORCM control and the condition of the power sources used or generated on the IORCM.

- CW_A and CW_B watchdog status [A_FAIL (CR3), B_FAIL (CR4): Red LEDs]
- CW_A and CW_B online status [A_ONLINE (CR1), B_ONLINE (CR2): Green LEDs]
- Power System "A" Status (CR6): +3.3V1, +3.3V2, +3.3V3 (Triple replicated programmable logic block power supplies): [Dual color LED indicators: Green = all OK, Red = one or more of these supplies has failed]
- Power System "B" Status (CR5): VCC_RED, RED_RLY_PWR, +3.3V4 (Logic input, relay and non-programmable logic power sources): [Dual color LED indicators: Green = all OK, Red = one or more of these supplies has failed]

A pair of power supply monitors drives its respective power status LED on the front panel to indicate a failure in one of the two supply groups. Group "A" includes the three independent programmable logic block power sources, while group "B" includes the fourth source that powers most remaining logic hardware, the fifth LED/power monitor source, and the VCC_RED and RED_RLY_PWR supplies that power the IORCM logic and port switching relays respectively.

1.3.3.2 CWREDIO IORCM Online Relays

Two sets of on-line relay contact outputs (A_ONLINE, B_ONLINE) are provided at IORCM Control Panel Terminal Block TB2. These outputs are cabled to the external CW units, where they are connected to input terminals of special I/O Redundancy Power Supply Sequencer Modules (PSSM) in the respective CW systems. Each online relay contact circuit uses two DPDT relays. The A_ONLINE circuit uses the normally closed versions of both 'A' and 'B' driven contacts connected in series (for fault tolerance). Conversely, CW_B online circuit uses the normally open contact sets in the same arrangement as stated above for CW_A. With CWIORSYS power not applied, the A_ONLINE contact circuit are closed to indicate CW_A unit should be primary.

Another set of relay contacts is available to indicate power supply system status, at Terminal Block TB3. This relay is energized if the power system is okay, and de-energized if the power system has failed.

1.3.3.3 Serial Communication Ports

An interconnect/relay system is used to switch up to four RS232/RS485 serial communications ports between the **PRIMARY** (selected) CW unit and field port connectors on the CWREDIO Control Panel (J1 - J4). Two 50 pin connectors (J5 & J6) on the Control Panel and custom cables are used to interconnect the communication port signals from the CW_A and CW_B units. An A/B Select signal from IORCM logic drives the communications relays to connect the appropriate ports of the online CW unit. For ports 1 and 2 (RS232

only) the switched signals are DTR, TXD, and RTS. For ports 3 and 4 the RS232 switched signals are RXD, DSR, DTR, TXD and GND, and in RS485 mode, the switched signals are RX-, RX+, TX-, TX+ and ISO GND. Surge suppression for all communications signals is provided.

1.3.3.4 Watchdog Inputs

System watchdog signals from external CW_A and CW_B units are cabled to Terminal Block TB1 on the CWREDIO Control Panel. These watchdog inputs are passed on to the IORCM Logic Board, where they are optically isolated and presented to the three redundant voting circuits. The input circuitry is designed for +24Vdc level inputs, and offers approximately 20 microseconds of delay filtering.

1.4 GENERAL DESCRIPTION

ControlWave™ Redundant I/O and Communications Switch Units (herein referred to as CWREDIO) provide redundancy control for two identical **ControlWave** Process Automation Controllers (CW) or two identical **ControlWave** I/O Expansion Racks (CWEXP) by switching control of the CPU, four non-Ethernet communications ports and up to 8 remotely terminated I/O Modules. CWREDIO units also provide field wiring termination for each of the I/Os associated with the redundant **ControlWaves** or **Control-WaveEXPs**. CWREDIOs employ scalable, modular hardware architecture with a modern and rugged industrial design that is both simple to install and configure.

Definitions of acronyms used herein are provided to assist the reader:

- CW **ControlWave** Process Automation Controller (CW_A or CW_B) with up to 8 Remotely Terminated I/O Modules. **Note: Rev. B or higher ControlWave CPU Modules must be used and their firmware must be Rev. 3.0 or higher.**
- CWEXP **ControlWave** I/O Expansion Rack (CWEXP_A or CWEXP_B) with up to 8 Remotely Terminated I/O Modules. **Note: Rev. B or higher ControlWave/ControlWaveEXP CPU Modules must be used and their firmware must be Rev. 4.10 or higher.**
- CWREDIO **ControlWave™** Redundant I/O and Communications Switch Unit
- IORB I/O Redundancy Backplane (part of CWREDIO)
- IORSM I/O Redundancy Switch Module (part of CWREDIO) - The system supports up to 8 IORSMs. IORSMs are available as AORSM, DORSM, DIRSM, AIRSM & UDIRSM versions. **Note: Although 1-5V or 4-20mA AIs can be connected to the appropriate Analog Input Redundancy Switch Module (AIRSM), only 1-5V ControlWave AI Modules are supported by redundant ControlWave Process Automation Controllers or redundant ControlWave I/O Expansion Racks.**
- IORCM I/O Redundancy Control Module (part of CWREDIO) - The IORC Module is a two-board assembly that monitors and controls the selection of the redundant **ControlWaves** (CPU, Communications and I/O).
- PSMM Power Supply/Monitor Module (part of CWREDIO) - Two PSMMs are utilized.

CWREDIOs are used in two basic types of redundancy control systems, i.e., **ControlWave** I/O redundancy (referred to as Local I/O redundancy) and I/O Expansion Rack redundancy. Local I/O Redundancy Systems are comprised of two identical **ControlWave** units, a CWREDIO, up to six external power supplies, cabling that ties each CW to the CWREDIO

and field wiring. I/O Expansion Rack Redundancy Systems are comprised of two identical **ControlWave** I/O Expansion Racks, a CWREDIO, up to six external power supplies and cabling that ties each CWEXP to the CWREDIO. **Note: The CW or CWEXP units used in conjunction with the CWREDIO must be equipped with Remotely Terminated I/O Modules.**

1.4.1 Overview of the Local I/O and I/O Expansion Rack Redundancy Control Systems

CWREDIO units support redundant operation of either **ControlWave** or **ControlWave** I/O Expansion Racks. Local I/O redundancy control systems employ a pair of **ControlWave** units while I/O Expansion Rack redundancy control systems employ a pair of **ControlWave** I/O Expansion Racks.

1.4.1.1 Overview of the Local I/O Redundancy Control Systems

Each **ControlWave** Process Automation Controller (CW_A & CW_B) used in conjunction with the Local I/O Redundancy Control System will have identical hardware including Power Supply/Sequencer Modules, CPU Modules (Including Secondary Comm. Boards) and remotely terminated I/O Modules. I/O Modules provide the circuitry necessary to interface the assigned field I/O devices. Each **ControlWave** I/O Module is interconnected to their associated I/O Redundancy Switch Module (IORSM) via discrete cable assemblies. A special communications cable interfaces the four **ControlWave** CPU Module communication ports to a 50-pin interface connector (J5 - CW_A or J6 - CW_B) on the **ControlWave**TM Redundant I/O and Communications Switch Unit's I/O Redundancy Control Module (IORCM) (see Figure 1-6).

A Local I/O Redundancy Control System can be part of a larger supervisory control and data acquisition (SCADA) system or it may exist as it's own autonomous control system, i.e., as a free standing redundant system that is not part of a broader network.

1.4.1.2 Overview of the I/O Expansion Rack Redundancy Control Systems

Each **ControlWave** I/O Expansion Rack (CWEXP_A & CWEXP_B) used in conjunction with the I/O Expansion Rack Redundancy Control System will have identical hardware including Power Supply/Sequencer Modules, CPU Modules (Including Secondary Comm. Boards) and remotely terminated I/O Modules. I/O Modules provide the circuitry necessary to interface the assigned field I/O devices. Each **ControlWave** I/O Expansion Rack I/O Module is interconnected to their associated I/O Redundancy Switch Module (IORSM) via discrete cable assemblies. A special communications cable interfaces the four **ControlWave**EXP CPU Module communication ports to a 50-pin interface connector (J5 - CWEXP_A or J6 - CWEXP_B) on the **ControlWave**TM Redundant I/O and Communications Switch Unit's I/O Redundancy Control Module (IORCM) (see Figure 1-7).

An I/O Expansion Rack Redundancy Control System can't exist without higher level control interface (Master Controller) since CWEXP CPUs are slave to either a **ControlWave** (CW) or a **ControlWave** Redundant Controller (CWRED). Communications between the Master Controller, CWEXP_A and CWEXP_B is via Ethernet connections. In general, one of three types of Master Controllers can be used in conjunction with an I/O Expansion Rack Redundancy System as follows:

- **ControlWave** Process Automation Controller (CW) - (Stand-alone or part of a larger network).

- **ControlWave Redundant Controllers (CWRED)** - (Stand-alone or part of a larger network).
- **ControlWave Redundant I/O and Communications Switch Unit (CWREDIO in a Local I/O Redundancy System)** - (Stand-alone or part of a larger network).

LOCAL I/O REDUNDANCY DIAGRAM

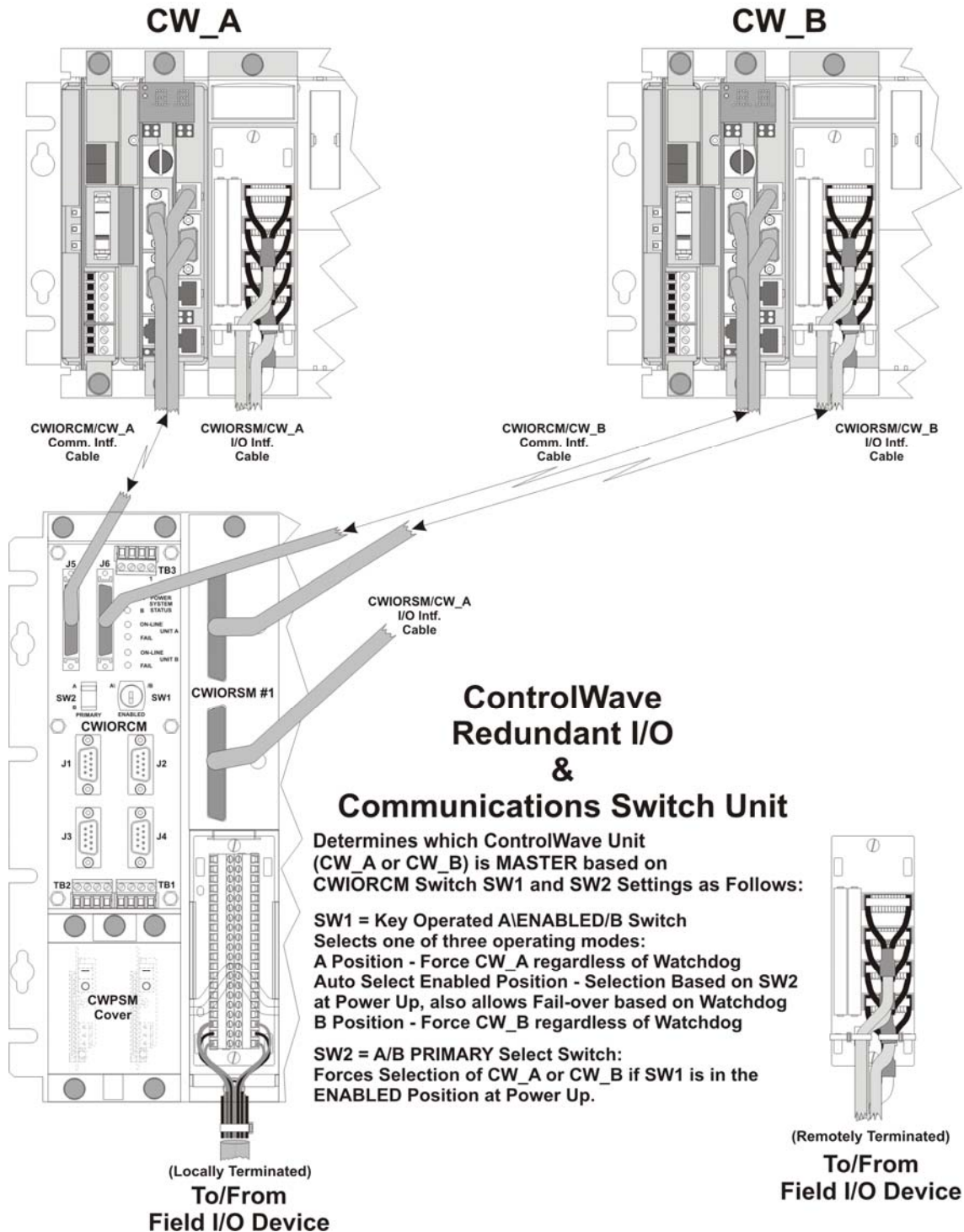

Figure 1-6 - Local I/O Redundancy System Diagram

I/O EXPANSION RACK REDUNDANCY DIAGRAM

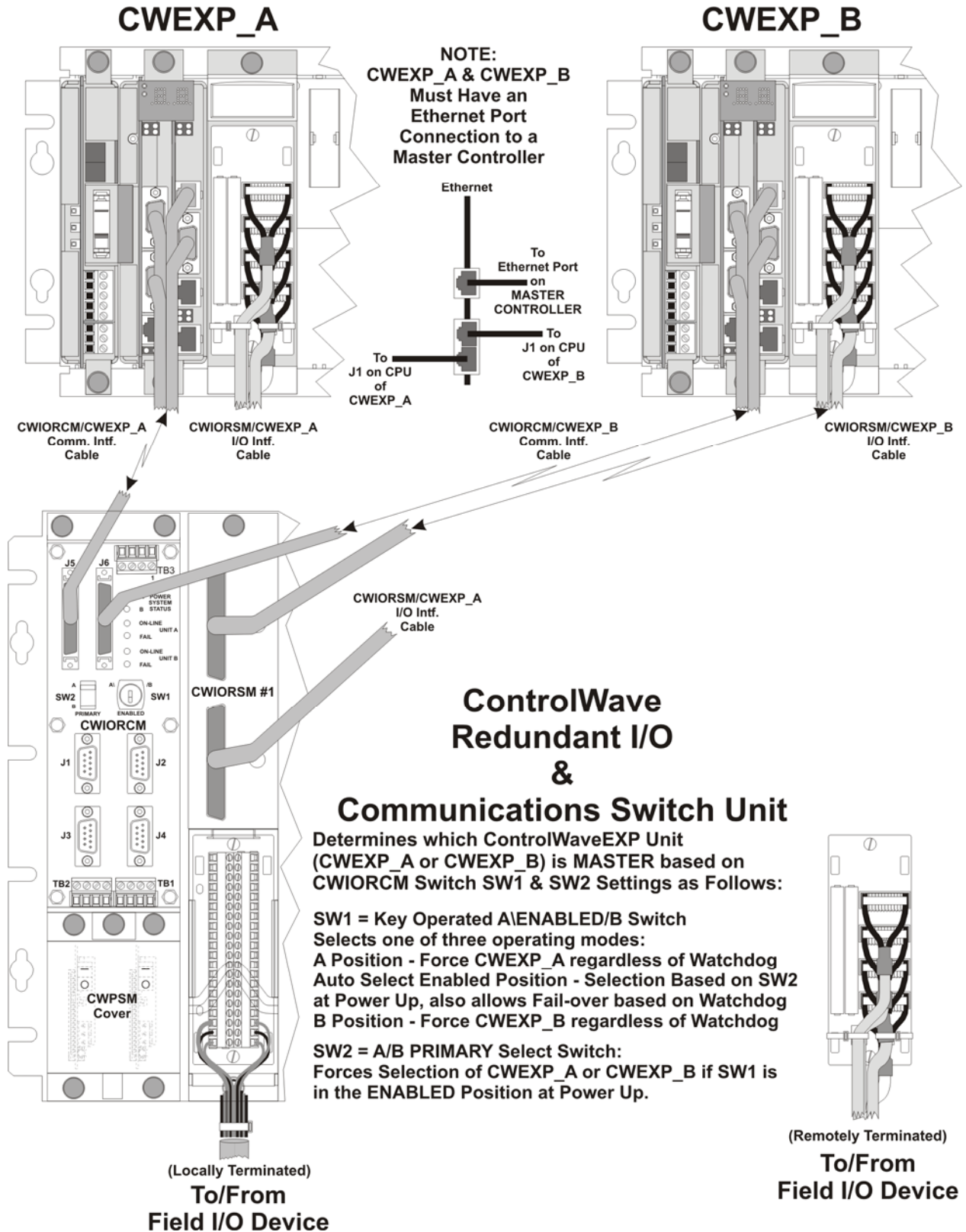

Figure 1-7 - I/O Expansion Rack Redundancy System Diagram

1.4.2 Overview of the ControlWave Redundant I/O and Comm. Switch Unit

Each CWREDIO contains one Backplane Board mounted in a Chassis. The I/O Redundancy Backplane (IORB) provides for the interconnection of the components that comprise the **ControlWave Redundant I/O and Comm. Switch Unit (CWREDIO)**. In addition to the IORB, **ControlWave Redundant I/O Comm. Switch Units** are comprised of a I/O Redundancy Control Module (IORCM), two Power Supply/Monitor Modules (PSMM) and up to eight I/O Redundancy Switch Modules (IORSM).

1.4.3 Key System Features

ControlWave Redundant I/O and Communications Units provide the following key features:

- Supports panel-mount, wall-mount or 19-inch rack-mount installations
 - Two RS-232 asynchronous serial ports (PC/AT 9-pin male D-sub connector)
 - Two factory configured RS-232/485 asynchronous serial ports (PC/AT 9-pin male D-sub connector)
 - Design supports fully redundant **ControlWave** operation for each I/O point
 - Design supports redundant **ControlWave** operation for full CPU Control, RS-232/485 Communications and all I/O
 - Redundant Power Supply/Monitor Boards
 - Up to eight I/O Redundancy Switch Modules: Each **CWREDIO** supports up to 8 redundant I/O Modules as follows:
 - Discrete Input Modules - 16/32 (24V) DIs
 - Discrete Output Modules - 16/32 (Open Source) DOs
 - Analog Input Modules - 8/16 (1-5V) Isolated Voltage Input AIs*
 - Analog Output Modules - 4/8 (4-20mA) Current Output AOs
 - Analog Output Modules - 4/8 (1-5V) Voltage Output AOs
 - Universal Digital Input Modules - 6/12 (12V or 24V) Isolated UDIs (for High/Low Speed Counting or Contact Closure operation)
- * **Note:** **Analog Input Redundancy Switch (AIRS) Modules that support 1-5V or 4-20mA operation are available. The 4-20mA AIRS Module employs 250-Ohm Resistors across each input to convert the signal from milliamperes to volts.**

1.5 PHYSICAL DESCRIPTION

CWREDIOs are comprised of the following major components:

One Chassis Assembly (see Section 1.5.1)

The Chassis Assembly used with the **ControlWave™ Redundant I/O and Communications Switch Unit (CWREDIO)** accommodates 19" rack-mount or panel/wall-mount installations.

One I/O Redundancy Backplane Ass'y. (IORB) (see Section 1.5.2)

The IORB provides electrical interconnection and accommodates mounting for the two Power Supply/Monitor Modules (PSMM), the I/O Redundancy Control Module (IORCM) and up to eight I/O Redundancy Switch Modules (IORSM).

Two Power Supply/Monitor Modules (PSMM) (see Section 1.5.3) These DC-to-DC Converters provide +5Vdc to the IORCM's Logic Board.

One I/O Redundancy Control Module (IORCM) (see Section 1.5.4)

Provides controlled switching (selection) of the **ControlWave/ControlWaveEXP** unit (CPU, Communications Ports and I/O) that is acting as the redundant system PRIMARY (on-line) Controller.

I/O Redundancy Switch Modules (IORSM) (see Section 1.5.5)

The system supports up to eight I/O Redundancy Switch Modules. IORS Modules are available in AO, DO, DI, AI & UDI versions. Each Module provides interconnection for I/O cabling of two identical (A/B) remotely terminated **ControlWave** I/O Modules. IORS Modules may be equipped with a locally terminated Terminal Block Assembly or remotely terminated Header Block Assembly. **Note: Control Switching (A/B Select) is only provided for output modules, i.e., for AORS and DORS Modules.**

1.5.1 Chassis Assembly

The Backplane PCB and the modules that comprise the system are housed in a Stainless Steel Chassis designed to accommodate redundant **ControlWave/ControlWaveEXP** operation. Any **ControlWave™** Redundant I/O and Communications Switch Unit (CWREDIO) Chassis can be 19-inch equipment rack-mounted or panel/wall-mounted. CWREDIO Chassis' are factory shipped without any modules installed. The Chassis assembly also contains a Ground Lug that accommodates up to a #4 AWG Ground Wire. Grounding the unit is accomplished by connecting a ground wire between the Ground Lug and a known good Earth Ground.

1.5.2 I/O Redundancy Backplane Assembly (IORB)

I/O Redundancy Backplane Assemblies (IORB) contain up to eleven (11) user accessible connectors (see Table 1-1). Connector P3 is equipped with a connector-coding device. This color-coded device is physically unique to ensure that only the correct Logic & Relay Board connector (P2) is installed.

IORB Connectors J1 & J2

The I/O Redundancy Backplane (IORB) provides interconnection of two Power Supply/Monitor Modules (PSMM) via 36-pin connectors J1 and J2. Redundant PSMMs provide failsafe power, i.e., continuous power if one PSMM fails.

IORB Connector P3

IORB Connector P3 is a 132-pin (male) connector that accommodates connection to the I/O Redundancy Control Module's (IORCM) Logic & Relay Board. The IORCM Logic & Relay Board connects to a piggy-back mounted IORCM Front Panel Board.

IORB Connectors J1 & J2

The **ControlWave** I/O Redundancy Backplane (IORB) provides interconnection of two Power Supply/Monitor Modules (PSMM) via 36-pin connectors J1 and J2. Two PSMMs provide failsafe power, i.e., continuous power if one PSMM fails.

IORB Connector P3

IORB Connector P3 is a 132-pin (male) connector that accommodates connection to the I/O Redundancy Control Module's (IORCM) Logic & Relay Board. The IORCM Logic & Relay Board connects to a piggy-back mounted IORCM Front Panel Board.

IORB Connectors P4 through P11

132-pin (male) IORB Connectors P4 through P11 accommodate connections to I/O Redundancy Switch Modules (IORSM) 1 through 8 respectively.

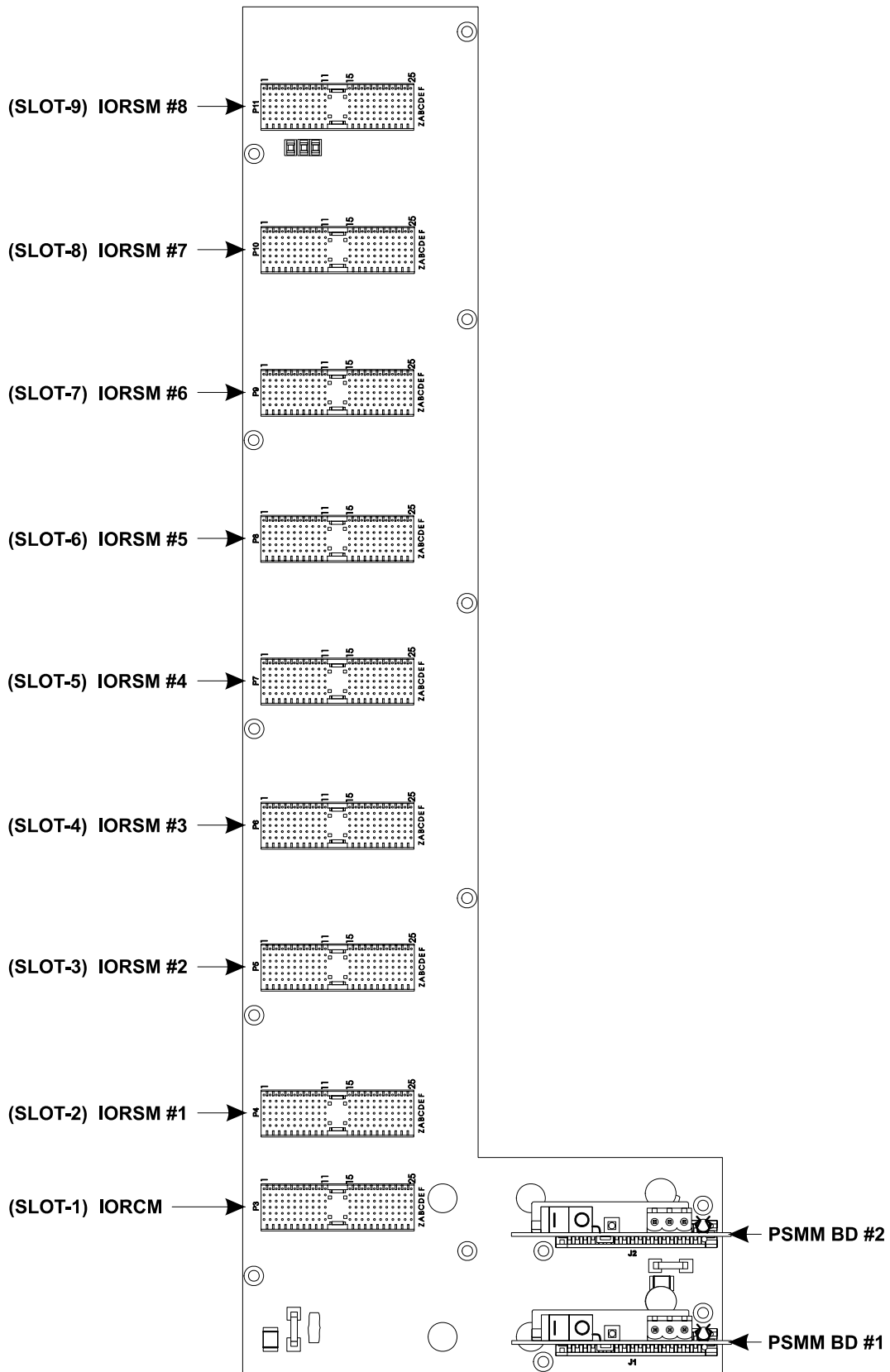

Figure 1-8 - ControlWave I/O Redundancy Backplane (CWIORB) with CWPSMs Installed

1.5.3 Power Supply/Monitor Modules (PSMM)

I/O Power Supply/Monitor Modules (PSMM) plug into the I/O Redundancy Backplane Assembly (IORB) (Connectors J1 & J2) via their 36-pin Card edge connector. The front of each PSMM contains a System Power Switch (SW1), as well as a pluggable 3-position Terminal Block (TB1) for external input power and CHASSIS Ground connections. Each PSMM has one LED, visible only when the Power Supply Cover Panel has been removed, that provides the following status conditions: Lit GREEN = 5V power is good, OFF = 5V power below 4.9Vdc.

A relay is provided at Terminal Block (TB3), that remains energized while power is good, but is de-energized if power fails. This relay could be used to trigger an external alarm in the event of a power failure.

PSMMs are designed to operate from 20.0Vdc to 30.0Vd and accept a 24Vdc bulk source and generate an isolated +5.2Vdc [regulated to 3.3Vdc (VCC) by the IORCM Logic Board] for the IORCM PLDs and up to eight I/O Redundancy Switch Modules (IORSM).

Also contained on the PSMM is the supply monitor circuit that monitors the incoming power as well as the isolated output supply voltages. The low limits for the bulk (incoming) supply voltage is 20.0V. The supplies are enabled when the input voltage is above its low limit. The monitor circuit for the isolated 5.2Vdc supply switches the status LED OFF when the supply voltage drops below 4.9Vdc.

The nominal settings for the power supply are ON state above 20.7Vdc and OFF state below 20.0Vdc. A supervisory circuit monitors the incoming power and the isolated supply voltages. The isolated supplies are shut down when the incoming voltage drops below +20.0Vdc.

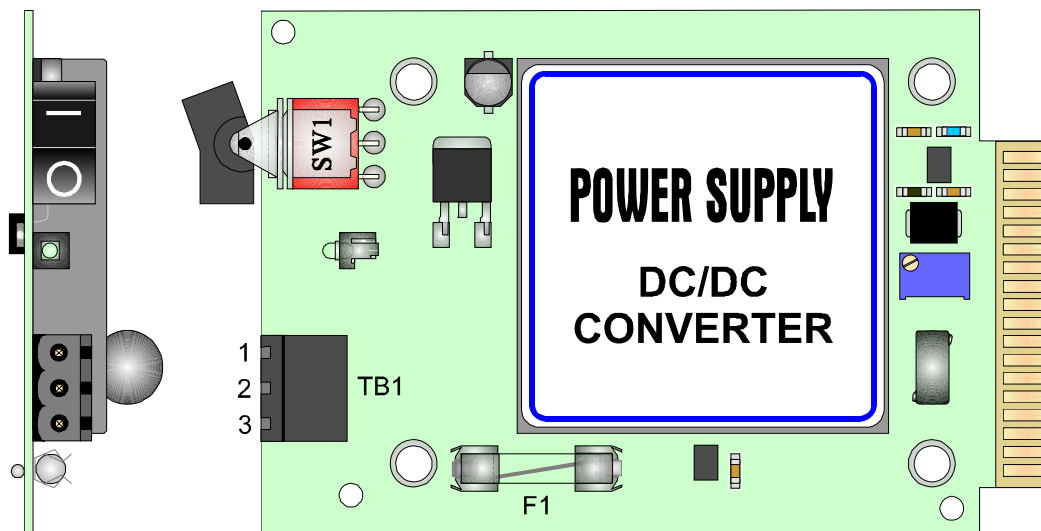

Figure 1-9 - ControlWave I/O Power Supply/Monitor Board

1.5.3.1 PSMM Power Switch SW1

Switch SW1 is used to connect input power to the PSSM circuitry when the I side of the switch has been pressed to its actuated position. This will turn the unit ON.

1.5.3.2 PSMM Board Fuse F1

Each PSMM contains one replaceable fuse (F1). Slow Blow Fuse F1 is rated at 5A and provides protection for the entire CWREDIO including DORSM field power.

1.5.3.3 PSMM Board Connectors

Pluggable connector TB1 and card edge connector P1 function as described below.

PSMM Bd. Terminal Block Connector TB1

TB1 accommodates input power and CHASSIS ground connections:

TB1-1 = (+VIN) (+20.7V to +30V dc for +24V Bulk Supply)

TB1-2 = (-VIN) (1st Supply Ground)

TB1-3 = Chassis Ground - CHASSIS (\neq)

PSMM Bd. Card Edge Connector P1

The 36-pin male card edge connector (P1) interfaces Power, Ground and CHASSIS Ground signals to Connector J1 or J2 on the Backplane Board.

1.5.3.4 PSMM LED

One LED per PSSM, visible when the Power Supply Cover Panel has been removed, will provide status conditions PWRGOOD (power good: green), and PWRDOWN (power down: OFF). The LED should be ON (green) whenever the unit is running and no power problems have been detected. The LED should only be OFF when the supply voltage for the isolated power (+5.2Vdc) has dropped below 4.9Vdc, nominal.

1.5.4 I/O Redundancy Control Module (IORCM)

The I/O Redundancy Control Module (IORCM) is comprised of two printed circuit boards (IORCM Panel PCB & the IORCM Logic & Relay PCB). In addition to the generation of A/B select signals to each of the IORS Modules, the IORCM generates an ONLINE status signal to CW_A and CW_B units that is derived from the WATCHDOG status signals of the CW_A and CW_B units and the settings of the mode control switches (SW1 & SW2) on the IORCM Panel PCB.

IORC Modules have been designed to provide the following functionality:

- Automatically select CW_A or CW_B racks upon power up when the A/B ENABLE Mode Switch (SW1) has been set in the Enabled position. A/B selection is prioritized by the settings on the A/B Primary Controller Select Switch (SW2). Allows fail-over to occur, based on watchdog state.
- Force the selection of the CW_A or CW_B unit with IORCM Key Operated A/B ENABLE Mode Switch (SW1) in A or B position regardless of the watchdog state of either **ControlWave/ControlWaveEXP** unit.
- Generation of individual A_ONLINE and B_ONLINE external status signals.
- Single point fault tolerance on internal signals, power supplies and switches. Signals that are not included are external watchdog signals.

- Display the Power System status of PSMM#1 and PSMM#2 individually.
- Display the status of external watchdog inputs.
- Display the status of the selected online **ControlWave/ControlWaveEXP** unit, i.e., UNIT A or UNIT B.

1.5.4.1 I/O Redundancy Control Module Connectors

I/O Redundancy Control Modules (IORCM) contain eleven connectors (nine 9 user accessible) (see Table 1-1).

IORCM Connector TB1

CW/CWEXP A/B isolated input watchdog signals used to establish master control are connected to the IORCM at 4-pin connector TB1.

IORCM Connector TB2

IORCM Connector TB2 provides relay contact output signals A_ONLINE and B_ONLINE for CW_A and CW_B **PRIMARY** (on-line MASTER) control selection.

IORCM Connector TB3

IORCM Connector TB3 provides relay contact output signals to indicate power system status.

IORCM 9-Pin Male D-Type Connectors J1 through J4

IORCM male 9-pin D-Type connectors J1 and J2 are factory set for RS-232 operation and represents COMM Port 1 and Comm Port 2 respectively of the **ControlWave/ControlWaveEXP** selected as **PRIMARY**. J3 and J4 are male 9-pin D-Type connectors that support factory configured RS-232 or RS-485 operation and represents COMM Port 3 and Comm Port 4 respectively of the **ControlWave/ControlWaveEXP** selected as **PRIMARY**.

**Table 1-1 - IORC Module User Accessible Connector Summary
(Unless Otherwise Noted Connectors are on the IORCM Panel Board)**

Ref.	# Pins	Function	Notes
TB1	4-pin	A/B Watchdog Input Signals	see Figure 1-10 & Table 4-3
TB2	4-pin	A_ONLINE & B_ONLINE External Output Signals	see Figure 1-10 & Table 4-3
TB3	4-pin	Power System Good / Failure	see Figure 1-10 & Table 4-3
J1	9-pin	D-Type COMM. Port 1 (RS-232)	see Figure 4-1 & Table 4-2
J2	9-pin	D-Type COMM. Port 2 (RS-232)	see Figure 4-1 & Table 4-2
J3	9-pin	D-Type COMM. Port 3 (RS-232 or RS-485 - Factory Configured)	see Figure 4-1 & Table 4-2
J4	9-pin	D-Type COMM. Port 4 (RS-232 or RS-485 - Factory Configured)	see Figure 4-1 & Table 4-2
J5	50-pin	CWA Comm Ports Interconnection	see Figure 4-2
J6	50-pin	CWB Comm Ports Interconnection	see Figure 4-2
P1	110-pin	Mates with J1 on CWIORC Logic & Relay PCB.	Not User Accessible
J1	110-pin	CWIORC Logic & Relay Board – Mates with P1 on Panel Board	Not User Accessible
J2	110-pin	CWIORC Logic & Relay PCB – Connects to P3 on the CWIORB	see Figures 2-3B & 4-4

IORCM Connectors J5 and J6

IORCM 50-pin female connectors accommodate interconnection of COMM Ports 1 through 4 as follows: J5 mates with Comm Ports 1 through 4 of CW_A while J6 does the same for CW_B.

IORCM Panel/Logic & Relay Connector P1/J1

110-pin IORCM Logic & Relay Board connector J1 mates to IORCM Panel Board connector P1 utilizing 5 rows of 22 pins marked A through E.

IORCM Logic/Backplane Connector J2

110-pin IORCM Logic & Relay Board connector J2 mates to IORB connector P3 utilizing 5 rows of 22 pins marked A through E.

1.5.4.2 I/O Redundancy Control Module Switches

A/B Primary Controller Select Switch (SW2) - 2-position - selects the PRIMARY Controller, i.e., CPU A (Unit A) or CPU B (Unit B) at power up only if the A/B ENABLE Mode Switch (SW1) has been set in the automatic selection (centered) position. The selected unit will be chosen as the PRIMARY System Controller if the I/O Redundancy Control Module (IORCM) determines that it is ready for on-line duty. Otherwise, the alternate unit will be selected if it is OK.

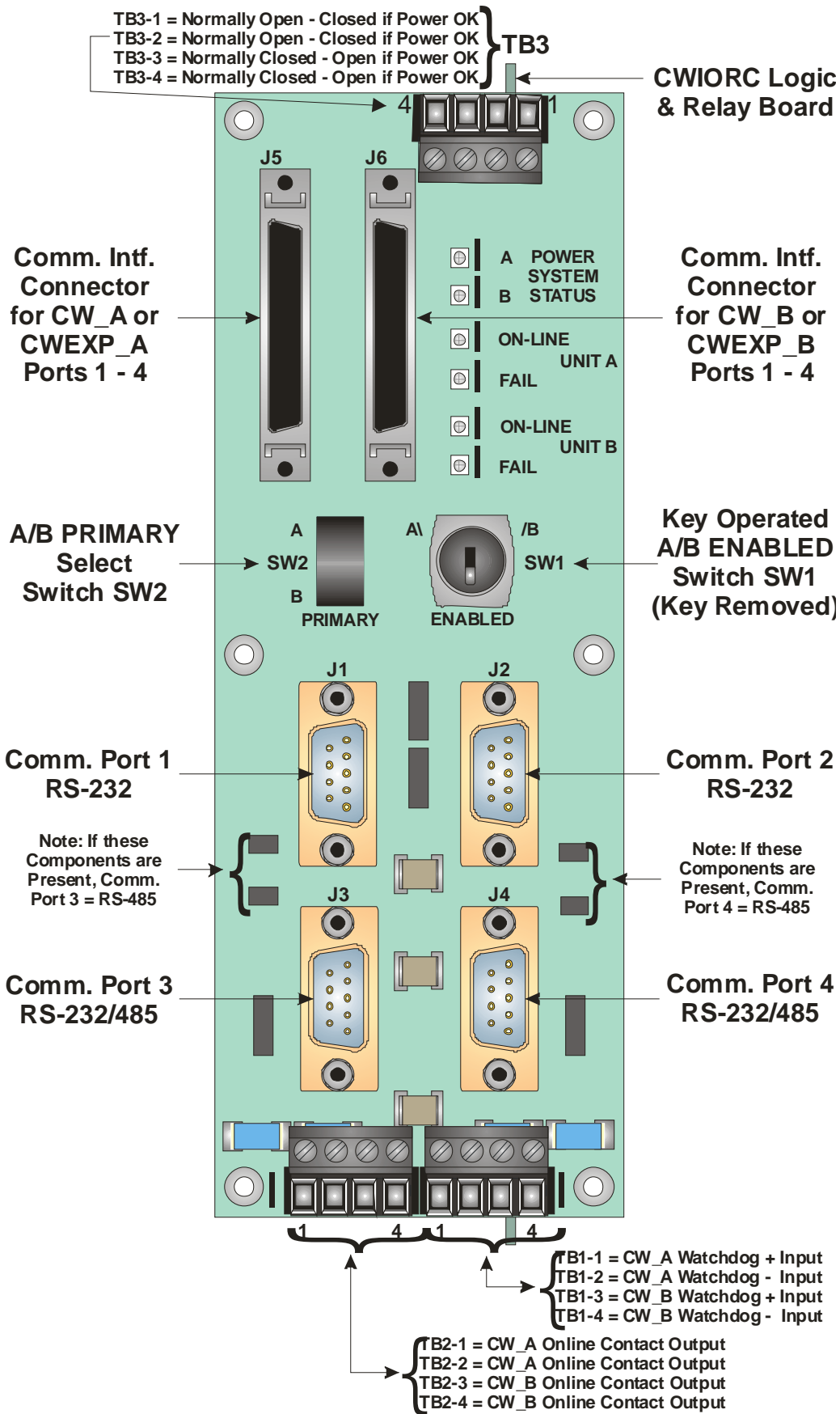

Figure 1-10 - ControlWave I/O Redundancy Control Module

A/B ENABLE Mode Switch (SW1) - 3-position (key operated) - used to determine whether the PRIMARY unit selected is forced to Unit A or Unit B or is automatically selected (Center). Forced primary selection is useful for diagnostic purposes, where a failed Unit A or Unit B CPU Module may be placed on-line for debugging. When set to the ENABLED position, Switch SW2 selects the PRIMARY Controller; the alternate (BACKUP) Controller is selected if the PRIMARY Controller goes into a watchdog state. Once selected, the alternate controller will remain the PRIMARY (on-line MASTER) irrespective of the original PRIMARY Controller's state.

1.5.4.3 I/O Redundancy Control Module LEDs

IORC Modules are equipped with 6 status LEDs (see Table 1-2).

Note: These status indicators are powered from independent power source +3.3V5 on the IORCM's Logic Board, and display the status of the external CW units under IORCM control and the condition of the power sources used or generated on the IORCM.

Table 1-2 - IORC Module LEDs

LED Name	LED Color	Function
CR1 - Unit A On-Line	Green	GREEN = CW_A is On-line as Primary Controller
CR2 - Unit B On-Line	Green	GREEN = CW_B is On-line as Primary Controller
CR3 - Unit A Fail	Red	RED = CW_A Watchdogged (failed)
CR4 - Unit B Fail	Red	RED = CW_B Watchdogged (failed)
CR5 - B Power System Status	Red Green	GREEN = +3.3V4, VCC_RED, RED_RLY PWR OK RED = At least one of the above supplies has failed
CR6 - A Power System Status	Red Green	GREEN = +3.3V1, +3.3V2, +3.3V3 are OK RED = At least one of the above supplies has failed

1.5.5 I/O Redundancy Switch Modules (IORSM)

I/O Redundancy Switch Modules (IORSM) are connected to identical remotely terminated I/O Modules housed in the two external **ControlWave/ControlWaveEXP** racks, i.e., CW_A and CW_B. Each IORSM provides interconnection with the I/O field devices associated with the redundant I/O Module pair. Each Output Redundancy Switch Module monitors the A/B select signal from the Backplane (IORB) and drives on board relays or MOSFETS to select the appropriate A/B **ControlWave/ControlWaveEXP** I/O Module. For Input Redundancy Switch Modules, the external signals are routed to both external **ControlWave/ControlWaveEXP** units without any switching mechanisms. Seven versions of I/O Redundancy Switch Modules are offered:

- Analog Output RSMs contain reed relays to switch between **ControlWave** units.
- Digital Output RSMs use power MOSFETs to switch the field power supply source and return.
- Externally Powered Digital Input RSMs have current limiting circuitry for each input. DIRSM Current limiting circuitry provides protection of the **ControlWave/ControlWaveEXP** unit DI channel transorb and limits the current to a damaged **ControlWave/ControlWaveEXP** DI Module when the channel fails shorted.

- Internally Sourced Digital Input RSMs contain a diode/transorb arrangement. If a transorb fails at the **ControlWave/ControlWaveEXP** unit, the diode will isolate the channel.
- Analog Input RSMs are offered in two versions: Voltage Input and Current Input. Voltage Input AIRSMs pass external 1 to 5 volt signals to both CW/CWEXP units. Current Input AIRSMs have a 250-ohm resistor across each input. These 250-ohm resistors convert a 4-20mA signal to a 1 to 5 V signal.

Note: The 4-20mA ControlWave Analog Input Module is NOT supported by the redundancy system, i.e., CW/CWEXP units must be equipped with Voltage Input AI Modules. Only Externally Powered AIs are supported. In lieu of the use of the Current Input AIRSM, a 250-ohm resistor may be placed across any or all Voltage Input AIRSM inputs.

- Universal Digital Input RSMs don't protect against I/O card faults.

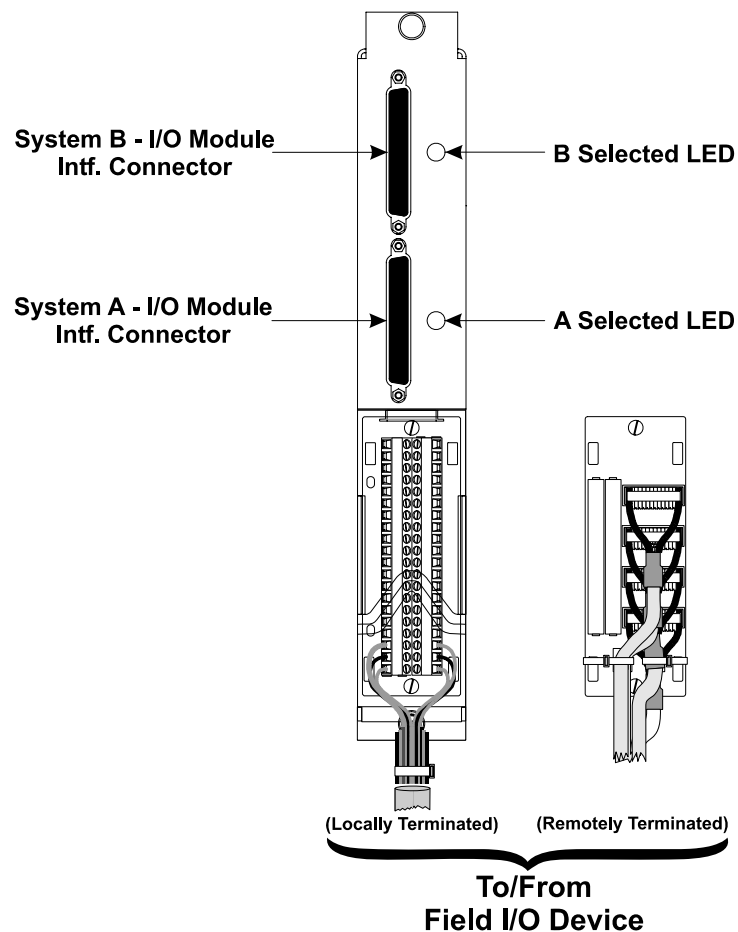

Figure 1-11 - I/O Redundancy Switch Module

1.5.5.1 I/O Redundancy Switch Module Connectors & LEDs

Each IORS Module is equipped with four connectors. Two upper panel connectors (J2 & J3) provide interconnection between the associated CW_A and CW_B I/O Modules respectively. A 110-pin connector (J1) mates with the associated Backplane Board connector, i.e., P4 through P11. A Terminal Block (for local terminations) or a Header Block (for remote

terminations) is situated behind the IORS Module's Terminal Housing Assembly and accommodates field wiring to the associated field devices.

Two LEDs are provided on each IORSM. The top LED (green) represents B On-line Status while the bottom LED (green) represents A On-line Status. The appropriate LED is lit when the associated CW_A or CW-B is selected as the **PRIMARY** Controller.

1.5.5.2 Associated ControlWave I/O Modules

Five remotely terminated I/O Modules are available. **Note: Redundant ControlWaves-/ControlWaveEXPs can't be equipped with locally terminated I/O Modules.** I/O Modules are factory configured, encased, and factory sealed. A brief overview of each I/O Module type is provided below. I/O Module specifications are covered in Section 4.5 of Instruction Manual CI-ControlWave. ControlWave I/O Modules are connected to their associated IORS Module via a discrete cable assembly equipped with four, 14-pin headers (on the ControlWave/ControlWaveEXP I/O Module end) and a 62-pin header (on the IORS Module end).

Analog Input Module

1-5 Vdc AI Modules are supported. Each module contains field interface circuitry for up to 16 or 8 analog inputs. Each AI Module consists of a Remote Terminal Board Assembly, an Analog Input PCB, an LED PCB, an LED Housing Assembly, a Terminal Housing Assembly, as well as I/O assembly and mounting hardware.

Analog Output Module

AO Modules are factory configured to support either 4-20mA or 1-5 Vdc analog outputs. Each module contains field interface circuitry for up to 8 or 4 analog outputs. Each AO Module consists of a Remote Terminal Board Assembly, an Analog Output PCB (with a daughter board when configured for 1-5V operation), an LED Housing Assembly, a Terminal Housing Assembly, as well as I/O assembly and mounting hardware.

Digital Input Module

Digital Input (DI) Modules are factory configured to support either externally powered source or dry contact DI applications. Each module contains field interface circuitry for up to 32 or 16 discrete inputs with an input range of 24Vdc, a nominal input current of 5mA and 30 millisecond input filtering. DI Modules consists of a Remote Terminal Board Assembly, a Discrete Input PCB, an LED PCB, an LED Housing Assembly, a Terminal Housing Assembly, as well as I/O assembly and mounting hardware.

Digital Output Module

Digital Output (DO) Modules provide a total of 32 or 16 DOs for control of signaling functions. Each output contains an optically isolated open source MOSFET and surge suppressor that are capable of handling 500mA @ 31V. DO Modules consists of a Remote Terminal Board Assembly, a Discrete Input PCB, an LED PCB, an LED Housing Assembly, a Terminal Housing Assembly, as well as I/O assembly and mounting hardware.

Universal Digital Input Module

Universal Digital Input (UDI) Modules provide a total of 12 or 6 inputs. Each input is optically isolated from the field device. UDI Modules are factory configured with all inputs set with debounce enabled or with all inputs set with debounce disabled. With debounce enabled, spurious pulses caused by relay contact bounce are eliminated. Individual UDI inputs can be customer configured for a polled input, interrupt on change of state (COS) or

totalizer operation. Field inputs can be driven signals, open collector outputs or relay contacts. The maximum input frequency is 10 kHz. For any input used as a totalizer, the maximum totaled count before rollover is 65535 and the totalizer is not resettable through software. UDI Modules consists of a Remote Terminal Board Assembly, a Universal Digital Input PCB, an LED PCB, an LED Housing Assembly, a Terminal Housing Assembly, as well as I/O assembly and mounting hardware.

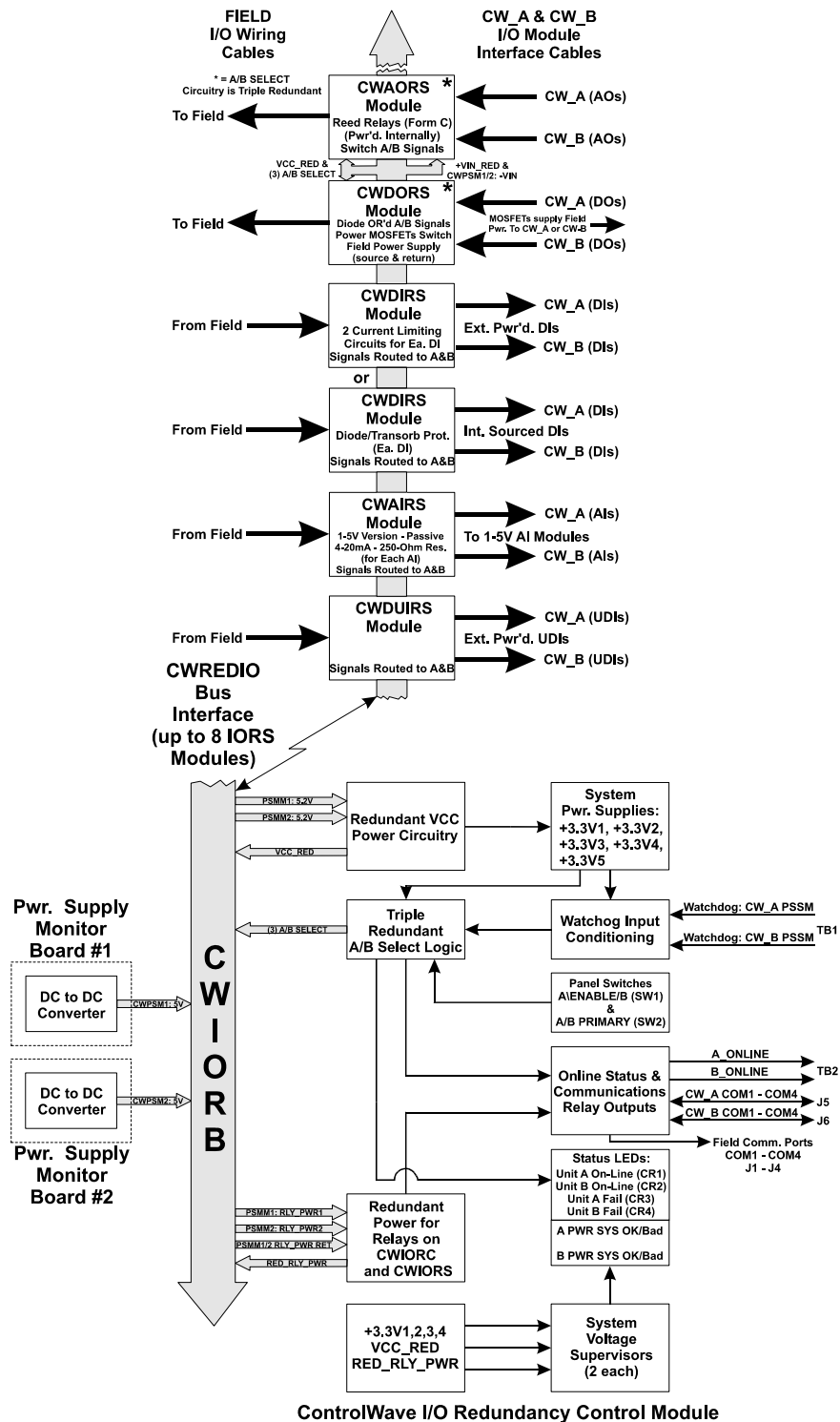

Figure 1-12 - ControlWave Redundant I/O and Communications Switch Unit Block Diagram

Section 2

INSTALLATION & OPERATION

2.1 INSTALLATION IN HAZARDOUS AREAS

ControlWave Redundant I/O and Control Communications Units (CWREDIO) are not furnished in an enclosure. The modules that comprise the system are housed in a Stainless Steel Chassis designed to accommodate up to eight I/O Redundancy Switch Modules (IORSM). Any CWREDIO can be panel/wall mounted. CWREDIO Chassis can mount to a 19" equipment rack in lieu of wall/panel mounting. Usage in Class I, Division 2, Groups A, B, C and D hazardous areas will require the selection of an appropriate enclosure that meets the NEMA Type 3X or 4X specification.

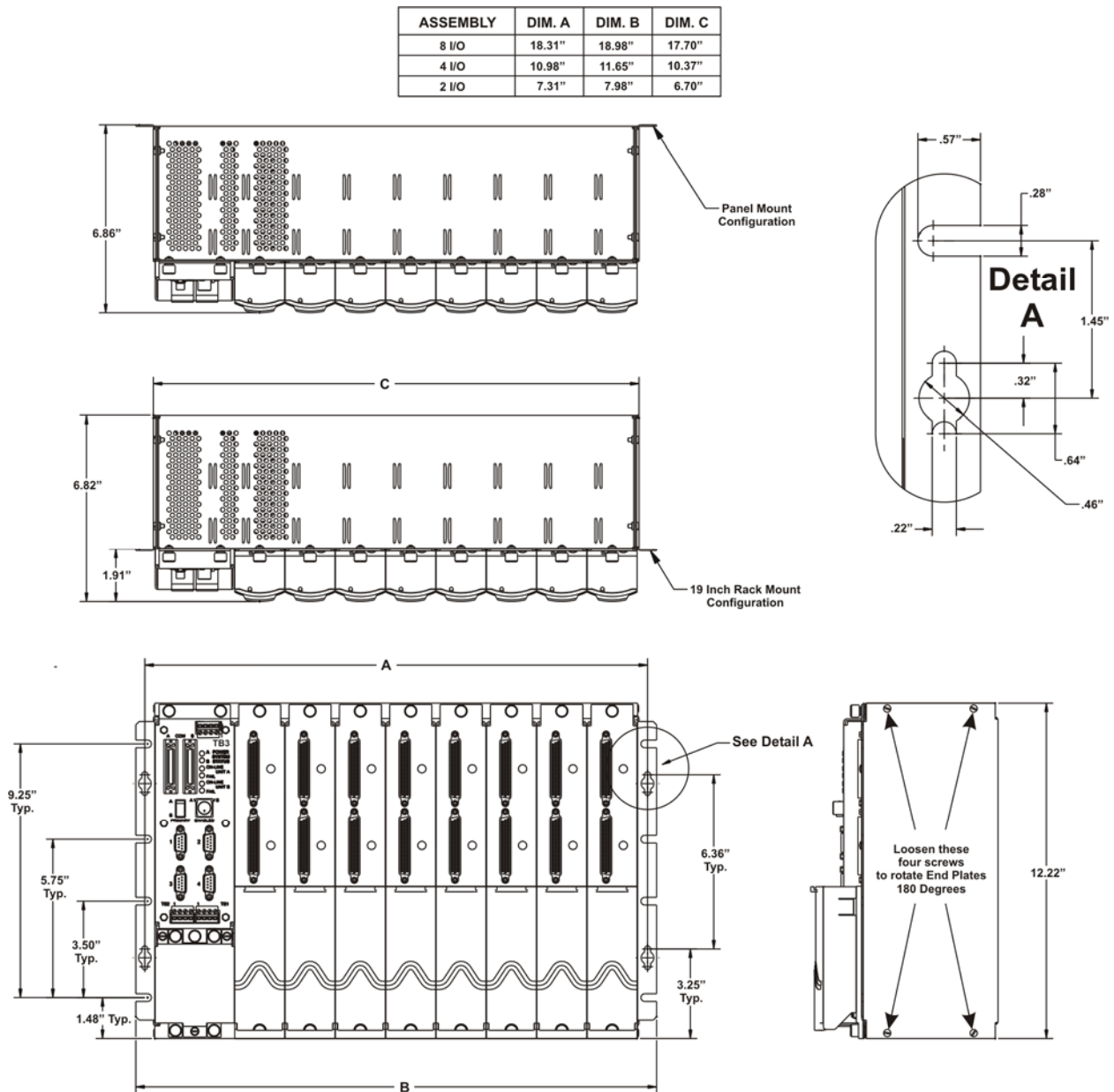

Figure 2-1 - ControlWave (CWREDIO) - Mounting Diagram

2.2 CWREDIO INSTALLATION SITE CONSIDERATIONS

Check all clearances when choosing an installation site. Make sure that the CWREDIO will be accessible for wiring and service. To install the CWREDIO Chassis, see Section 2.3.1.

2.2.1 Temperature & Humidity Limits

CWREDIOs have been designed to operate over a -40°F to +158°F (-40°C to +70°C) temperature range (with storage at up to +185°F (+85°C)) and a 0% to 95% Relative Humidity range. Make sure that the ambient temperature and humidity at the measuring site remains within these limits. Operation beyond these ranges could cause output errors and erratic performance. Prolonged operation under extreme conditions could also result in failure of the unit.

2.2.2 Vibration Limits

Check the mounted enclosure, panel or equipment rack for mechanical vibrations. Make sure that the CWREDIO is not exposed to a level of vibration that exceeds those given in the specifications. The CWREDIO's vibration limits are 1g for 10 - 150 Hz & .5g for 150 - 2000 Hz.

2.3 CWREDIO INSTALLATION/CONIGURATION

ControlWave Redundant I/O and Communications Switch Unit components are shipped from the factory in separately boxed modules as follows:

- CWREDIO Chassis Assembly with I/O Redundancy Control Module (IORCM) and two Power Supply/Monitor Modules (PSMMs) installed. Redundant Communication Cables are provided in the shipping box.
- I/O Redundancy Switch Module (IORSM) - Two I/O Module Interface Cables are provided with each IORSM. From 1 to 8 IORSMs are provided separately boxed for each CWREDIO as follows:
 - AORSM - AO Redundancy Switch Module
 - AIRSM - AI Redundancy Switch Module
 - DORSM - DO Redundancy Switch Module
 - DIRSM - DI Redundancy Switch Module
 - UDIRSM - UDI Redundancy Switch Module

Overview of Configuration

An overview of the steps required to configure a **ControlWave** Redundant I/O and Communications Switch Unit and the related redundant components is provided below.

Step 1. Hardware Configuration

This involves unpacking the CWREDIO hardware, mounting the chassis, configuring and installing the various hardware modules, installing interconnect cables between each **ControlWave** Process Automation Controller or each **ControlWave** I/O Expansion Rack and the CWREDIO, wiring I/O terminations, making proper ground connections, and wiring the **ControlWave** Power Supply/Monitor Modules (PSMMs) to bulk power supplies. To install and configure the **ControlWave** Redundant I/O and Communications Switch Unit follow steps 1 through 10 below:

1. Remove the Chassis from its carton and install it at its assigned work site (see Section 2.3.1).
2. Remove the various CWREDIO Modules from their cartons and install them into their designated slots (see Figure 2-6).
3. Connect the Redundant CW Communication Cables as follows: Connect one end of Comm. Interface Cable A to Comm. Ports 1 through 4 of CW_A or CWEXP_A and the other end to Comm. Interface Connector J5 of the I/O Redundancy Control Module (IORCM) on the CWREDIO. Connect one end of Comm. Interface Cable B to Comm. Ports 1 through 4 of CW_B or CWEXP_B and the other end to Comm. Interface Connector J6 of the IORCM on the CWREDIO).
4. Connect network communications cables to the IORCM as follows (see Section 2.3.1.3):
 Comm. Port 1 = J1 - RS-232
 Comm. Port 2 = J2 - RS-232
 Comm. Port 3 = J3 - RS-232 or RS-485 (factory configured per order)
 Comm. Port 4 = J4 - RS-232 or RS-485 (factory configured per order)
5. Install I/O wiring to each IORSM (see Sections 2.3.2 through 2.3.2.8.1).
6. Install a ground wire between the Chassis Ground Lug and a known good Earth Ground (see Section 2.3.1.1).
7. Install switchover control wires (not provided) between IORCM pluggable terminal block connectors TB1 and TB2 to CW_A and CW_B (or CWEXP_A and CWEXP_B) Power Supply/Sequencer Module (PSSM) pluggable connectors TB1 respectively (see Section 2.3.3.3).
8. Remove the Power Supply Panel Cover (secured via three screws) and connect Bulk DC Power to the pluggable terminal block connector TB1 on each of the two PSMMs (see Sections 2.3.3.1 & 2.3.3.2). **Note: It is recommended that the pluggable terminal block (TB1) associated with each PSMM are not connected until the entire system has been wired and configured. When ready turn both PSMMs to their ON position via SW1 (' T ' pressed) on each PSMM.**
9. Optionally connect terminal block connector TB3 to an external discrete input (DI) for reporting on the 'health' of the power supply system.
10. Install the Power Supply Panel Cover removed in step 8. This item is secured to the Chassis via three screws; two on top and one on the bottom.
11. Configure each of the **ControlWave** units (CW_A and CW_B) (or CWEXP_A and CWEXP_B) associated with the redundancy system. Establish the side-load Ethernet communication connections at CW_A and CW_B. Apply power to them by setting the Power Switch on their PSSM Modules to the ' T ' position. After receiving their Application Loads (see Steps 2 below and Section 2.4.1 of CI-ControlWaveEXP and/or CI-ControlWave), the redundancy I/O system will be ready for on line operation.

Step 2. Redundant ControlWave or Redundant ControlWaveEXP Configuration

Both **ControlWaves**, i.e., CW_A and CW_B (CWEXP_A and CWEXP_B), must be installed and configured for redundant operation in the redundancy I/O system. Section 2.3 of Instruction Manual CI-ControlWave details the seven steps required to configure the **ControlWave** Process Automation Controllers; while Section 2.3 of Instruction Manual CI-ControlWaveEXP details the three steps required to configure the **ControlWave** I/O Expansion Racks. **Note: Both ControlWaves (ControlWaveEXPs) must be identical (except for IP Addresses and CPU Switch settings) and must be equipped with Rev. B or higher CPU Boards that are running with ControlWave firmware (Rev. 4.10 or higher).**

LOCAL I/O REDUNDANCY DIAGRAM

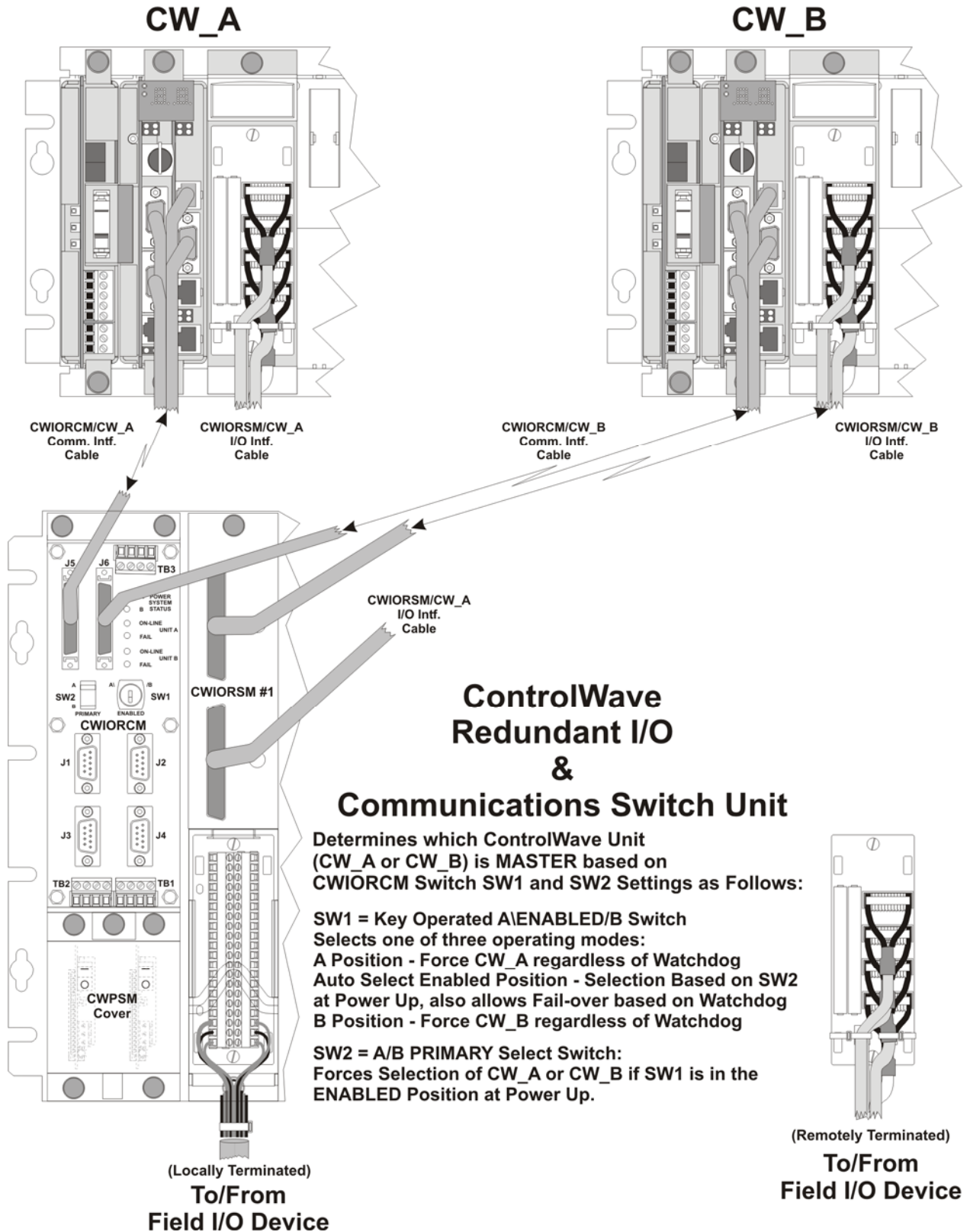

Figure 2-2 - Local I/O (ControlWave) Redundancy Diagram
 (see Figure 1-7 for I/O Expansion Rack Redundancy Diagram)

2.3.1 Mounting ControlWave Redundant I/O and Comm. Switch Units

ControlWave Redundant I/O and Comm. Switch Units (CWREDIO) can be mounted to a 19-inch equipment rack, a panel or a wall. These CWREDIOs are factory shipped with the End Plates configured for 19-inch rack mounting. When mounting one of these units to a panel or wall, it is to be positioned in accordance with the following restrictions:

- The End Plates must be removed, rotated 180° and then reinstalled to accommodate panel or wall mounting. Hole patterns and dimensions are provided in Figure 2-1.
- The unit must be positioned so that the front of the assembly is visible and the unit is accessible for service, i.e., removal, installation and maintenance of various modules, field wiring and fuse replacement.
- Modules should not be installed until the CWREDIO's Chassis has been mounted and grounded at a designated work site.

2.3.1.1 CWREDIO Grounding

ControlWave Redundant I/O and Communications Switch Unit Chassis are provided with a Ground Lug that accommodates up to a #4 AWG wire size. A ground wire must be run between the Chassis Ground Lug and a known good Earth Ground. The cases of the various I/O Redundancy Switch Modules (IORSM) are connected to Chassis Ground when they have been installed and secured via their two Captured Panel Fasteners. As an extra added precaution, it is recommended that a #14 AWG wire be run from both PSMM Board Power Connectors (TB1-3 - Chassis Ground) to the same known good Earth Ground. The following considerations are provided for the installation of CWREDIO system grounds:

- Chassis Ground Lug to Earth Ground wire size should be #4 AWG. It is recommended that stranded copper wire is used and that the length should be as short as possible.
- This ground wire should be clamped or brazed to the Ground Bed Conductor (that is typically a stranded copper AWG 0000 cable installed vertically or horizontally).
- The wire ends should be tinned with solder prior to insertion into the Chassis Ground Lug. *Note: Use a high wattage Soldering Iron.*
- The ground wire should be run such that any routing bend in the cable has a minimum radius of 12-inches below ground and 8-inches above ground.

2.3.1.2 Communication Ports

A **ControlWave** Process Automation Controller can be configured as a Master or Slave node on a MODBUS network, a BSAP network, an Ethernet (using Internet Protocol) or a network utilizing a custom third party protocol (see Bristol Manual D5125). A **ControlWave** I/O Expansion Rack can be configured as a Slave to a host **ControlWave** on a Serial MODBUS or Open MODBUS network or it may be connected to a **ControlWave** via IP. The I/O Redundancy Control Module (IORCM) supplied with the CWREDIO supports four communication ports.

Communication Ports 1 through 4 support asynchronous operation. Communication Ports COM1 and COM2 support RS-232 operation while COM3 and COM4 are individually factory configured per order for RS-232 or RS-485 operation. RS-232 and RS-485 Ports are protected to ±8KV ESD (Contact). Ethernet and RS-485 Ports are isolated to 500Vdc.

Any of the four IORCM communication ports (see Figure 2-3A/B) can be configured for local communications, i.e., connected to a PC loaded with **ControlWave** Designer and OpenBSI

software. Connections for the 9-pin, RS-232/485 interface are shown in Figure 2-4, while the corresponding pin labels are provided in Table 2-3.

2.3.1.3 RS-232 & RS-485 Interfaces

Communications Ports (COM1 & COM2) support RS-232 communications only. RS-232 or RS-485 communications (one or the other - factory configured) can be provided by Comm. Ports COM3 and COM4. These connectors are summarized below.

IORC Module J1 - 9-Pin Male D-Sub - RS-232 - COM1 - Port 1

IORC Module J2 - 9-Pin Male D-Sub - RS-232 - COM2 - Port 2

IORC Module J3 - 9-Pin Male D-Sub - RS-232/RS-485 - COM3 - Port 3

IORC Module J4 - 9-Pin Male D-Sub - RS-232/RS-485 - COM4 - Port 4

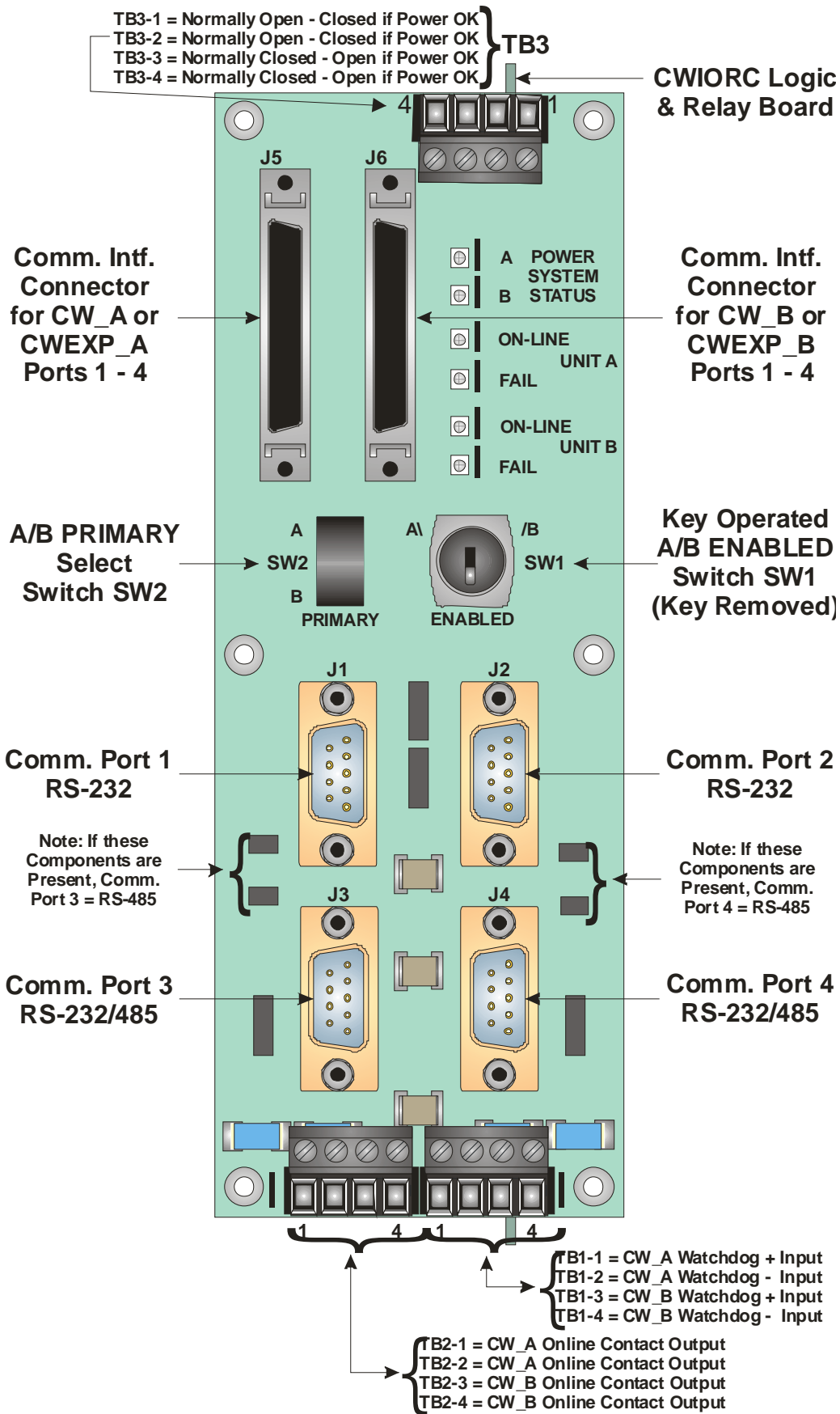

Figure 2-3A - IORC Module Component Identification Diagram (Front)

RS-232 Ports

An RS-232 interface supports point to point half-duplex and full-duplex communications (20 feet maximum, using data quality cable). Half-duplex communications supported by the associated **ControlWave** or **ControlWaveEXP** utilize MODBUS or BSAP protocol, while full-duplex is supported by the Point to Point (PPP) protocol. RS-232 ports utilize the “null modem” cable (Figure 2-4A) to interconnect with other devices such as a PC or another **ControlWave** series unit (except CW_10/30/35) unit when the **ControlWave** or **ControlWaveEXP** is communicating using the full-duplex PPP protocol. The half-duplex cable shown in Figure 2-4A is utilized when the CWREDIO port in question is connected to a **ControlWave** series unit (except CW_10/30/35). If communicating with a Bristol series 3305, 3310, 3330, 3335 or CW_10/30/35 RTU/DPC, one of the cables shown in Figure 2-4B must be used. Refer to Figure 2-4C to connect a **ControlWave/ControlWaveEXP** to either a modem or radio via the CWREDIO’s IORCM. When connecting to **ControlWave** COM3 (Port 3) as an RS-232 port, the cable of Figure 2-4D must be utilized along with either a DB9 Male to Female Adapter or the cable of Figure 2-4A.

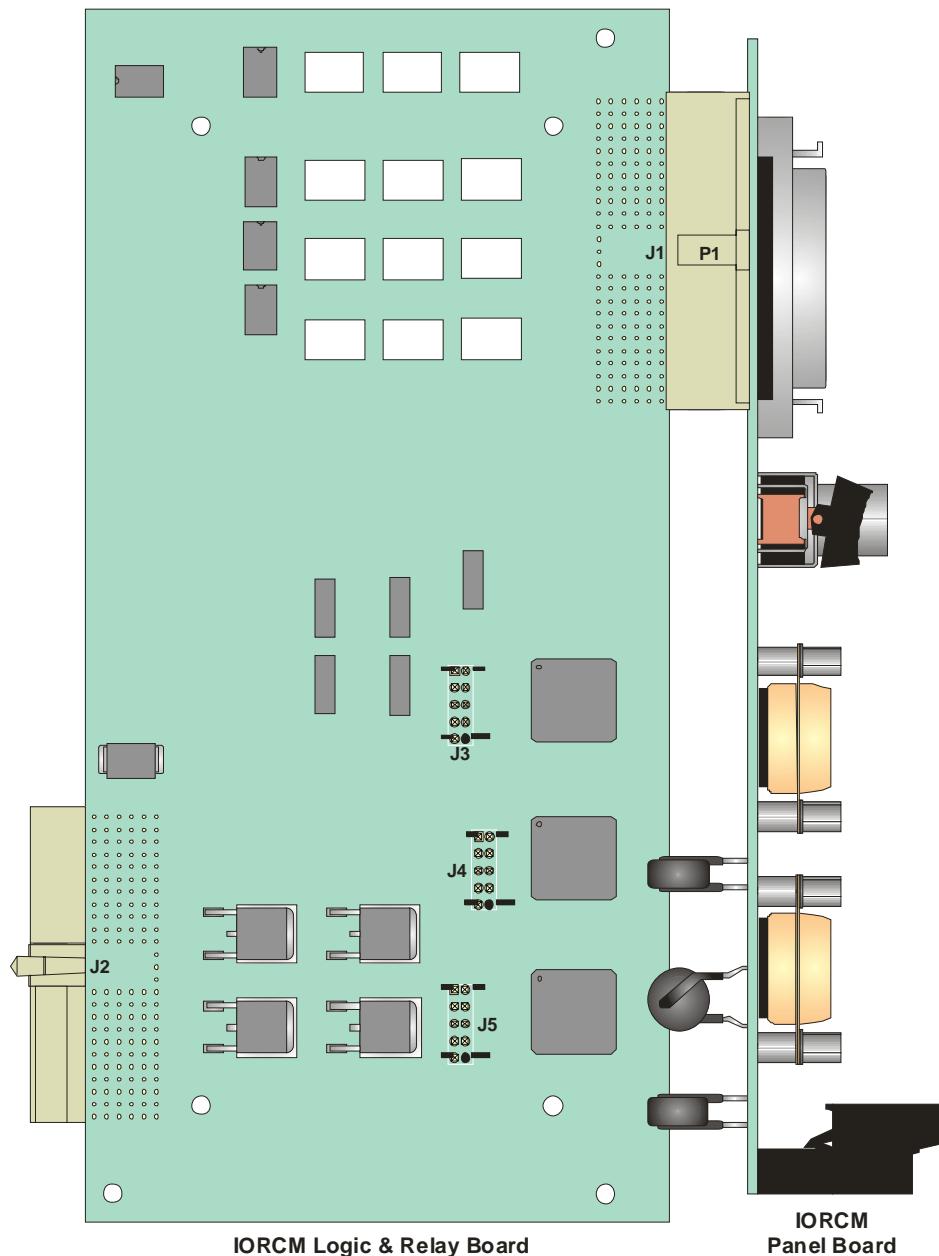

Figure 2-3B - IORCM Module Component Identification Diagram (Left Side)

An illustration of the IORCM's male 9-pin D-type connectors is provided in Figure 2-5. Table 2-1 provides the connector pin assignments for IORCM communication ports 1 through 4.

Note: The following facts regarding **ControlWave** I/O Expansion Rack RS-232 serial communications ports should be observed when constructing communications cables:

- DCD must be high to transmit (except during Modem Dialing)
- CTS must be high to transmit
- When port is set for full-duplex operation - RTS is always ON
- DTR is always high (when port is active)
- When port is set for half-duplex operation - CTS must go low after RTS goes low

Table 2-1 - COM1 through COM4 Connector Pin Assignment

Pin #	Signal RS-232	Description: RS-232 Signals	Signal RS-485	Description: RS-485 Signals - COM3/4
1	DCD	Data Carrier Detect Input		N/A
2	RXD	Receive Data Input	RXD-	Receive Data - Input
3	TXD	Transmit Data Output	TXD-	Transmit Data - Output
4	DTR	Data Terminal Ready Output	TXD+	Transmit Data + Input
5	GND	Signal/Power Ground	ISOGND	Isolated Ground
6	DSR	Data Set Ready Input	RXD+	Receive Data + Output
7	RTS	Request To Send Output		N/A
8	CTS	Clear To Send Input		N/A
9	RI	Ring Indicator		N/A

Note: RS-485 Signals in Table 2-3 are only available on COM3 or COM4.

RS-485 Ports

CWREDIO units can use an RS-485 configured port for local network communications to multiple nodes up to 4000 feet away. Since this interface is intended for network communications, Table 2-2 provides the appropriate connections for wiring the master, 1st slave, and nth slave. Essentially, the master and the first slave transmit and receive data on opposite lines; all slaves (from the first to the "nth") are paralleled (daisy chained) across the same lines. The master node should be wired to one end of the RS-485 cable run. A 24-gauge paired conductor cable, such as Belden 9843 should be used. *Note: Only half-duplex RS-485 networks are supported.*

Table 2-2 - RS-485 Network Connections

(see Table 2-1 & Figure 3-12 for **ControlWave** RS-485 Port Pin # Assignments)

From Master	To 1st Slave	To nth Slave
TXD+	RXD+	RXD+
TXD-	RXD-	RXD-
RXD+	TXD+	TXD+
RXD-	TXD-	TXD-
ISOGND	ISOGND	ISOGND

Note: Pins 1, 2, 3, 4 & 9 of Bristol Series 3305, 3310, 3330, 3335 & 3340 RTU/DPC RS-485 Comm. Ports are assigned as follows: 1 = TXD+, 2 = TXD-, 3 = RXD+, 4 = RXD- & 9 = ISOGND.

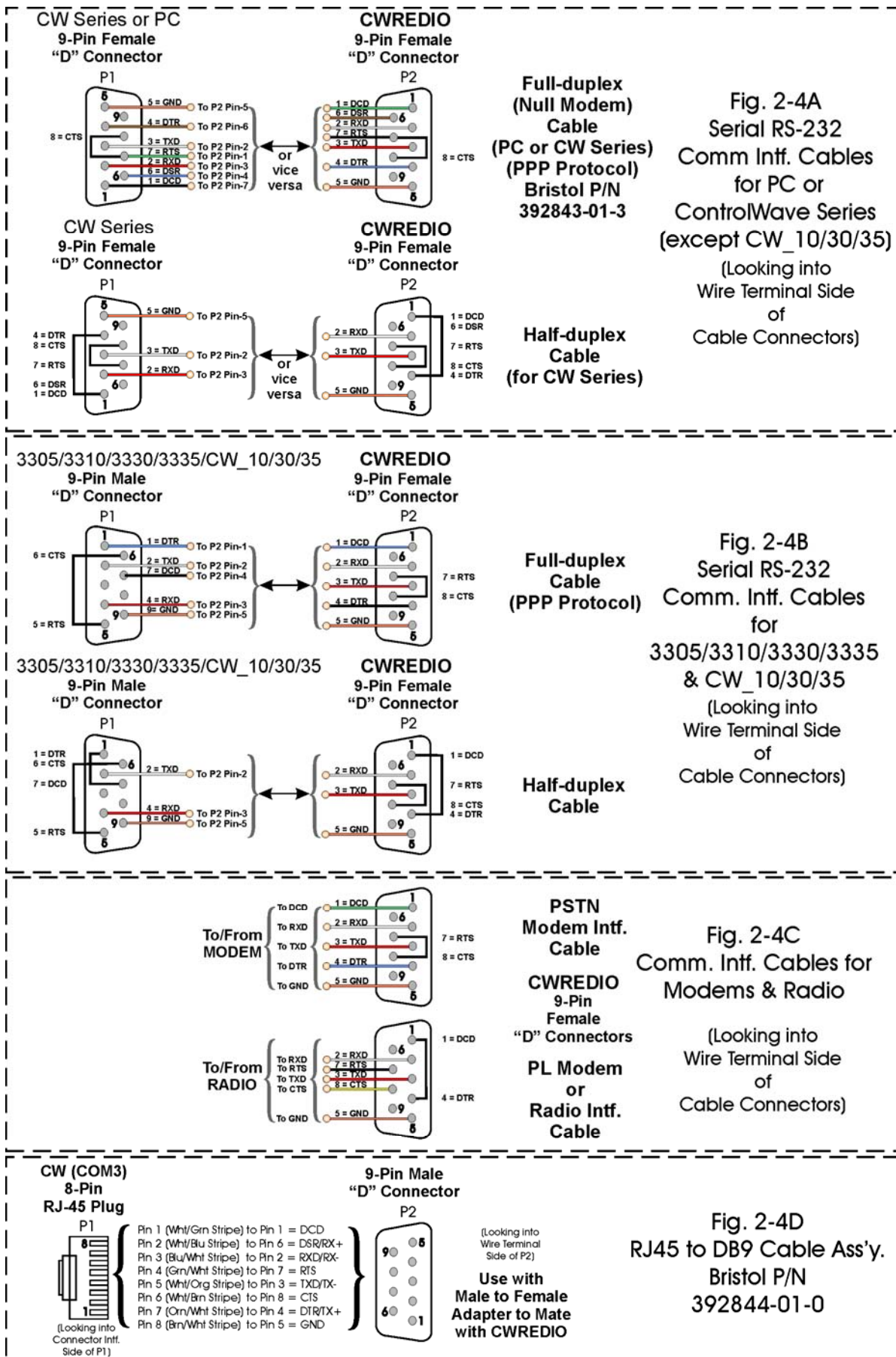

Figure 2-4 -Communication Port RS-232 Cable Wiring Diagrams

To ensure that the “Receive Data” lines are in a proper state during inactive transmission periods, certain bias voltage levels must be maintained at the master and most distant slave units (end nodes). These end nodes also require the insertion of 100-Ohm terminating resistors to properly balance the network. ControlWave/ControlWaveEXP Secondary Communication Board switches must be configured at each node to establish proper network performance. This is accomplished by configuring SCB Switch SW1 (Comm. Port 3) and/or SCB Switch SW4 (Comm. Port 4) so that the 100-Ohm termination resistors and biasing networks are installed at the end nodes and are removed at all other nodes on the network (see Table 2-3 below and Figure 2-11 in Section 2.3.3.3 of CI-ControlWave).

Looking into Bd. Receptacle

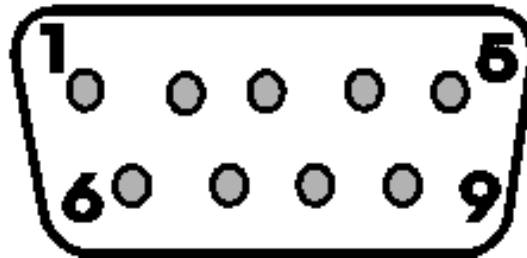

Figure 2-5 - Male DB9 9-Pin Connector Associated with COM1 through COM4

Table 2-3 - SCB Port Switches SW1 = COM3, SW4 = COM4
Loopback & Termination Control

SWITCH #	RS-232 Function Switch ON	RS-485 Function Switch ON	Setting
1	DTR to DSR Loopback	TX+ to RX+ Loopback	ON - Only for Diagnostics
2	TXD to RXD Loopback	TX- to RX- Loopback	ON - Only for Diagnostics
3	N/A	100 Ohm RX+ Termination	ON - End Nodes Only
4	N/A	100 Ohm RX- Termination	ON - End Nodes Only
5	RTS to CTS Loopback	N/A	ON - Only for Diagnostics
6	N/A	Slow Slew Rate - ON = Fast OFF = Slow	ON/OFF - As required Factory Default = ON
7	N/A	RX+ Bias (End Node)	ON - End Nodes Only
8	N/A	RX- Bias (End Node)	ON - End Nodes Only

Closed = Switch set OFF

2.3.2 I/O Redundancy Switch Module Installation & Wiring

ControlWave Redundant I/O and Communications Switch Unit Chassis are support up to 8 I/O Redundancy Switch Modules (IORSMS). IORSMS reside in slots 2 through 9. Figure 2-6 shows the ControlWave Redundant I/O and Communications Switch Unit Chassis slot assignments.

IORSMS are configured per order and individually packaged. An IORSMS will reside in one of up to 8-I/O slots supported by Backplane Interface connectors P4 through P11.

2.3.2.1 Installation of I/O Redundancy Switch Modules

The ControlWave Redundant I/O and Communications Switch Unit must be shut down prior to the installation (or removal) of any component. When adding one or more IORSMS (along with ControlWave I/O Modules at CW_A/CWEXP_A and CW_B/CWEXP_B), the

application load in **ControlWave Designer** must be configured to accept the new I/O Module(s) and then the new application load must be downloaded into both **ControlWave** units before the new I/O Module(s) can become operational. For new site installations, hardware configuration should take place with power disconnected until the entire unit has been physically installed, configured and wired.

Perform steps 1 through 7 below for each IORSM. IORSMs are provided with a removable Terminal Housing Assembly. This assembly has a door that swings downward to provide access to the unit's Terminal Handle which in turn is utilized to add in the removal of an installed IORSM once the module's Captured Panel Fasteners have been loosened.

1. Remove the IORSM from its shipping carton and remove the Terminal Housing Assembly from the IORSM (see Figure 2-7).
2. Turn the Terminal Block's Quarter Turn Fasteners (counterclockwise) and remove the Terminal Block Assembly from the IORSM.
3. IORS Modules are available that support local terminations (field wiring connected directly to the IORS Module's Terminal Block PCB) or remote terminations (field wiring connected to a remote DIN-rail mounted Terminal Block Assembly).

When installing wiring in conjunction with IORSMs that are equipped with a Local Terminal Block PCB, install the field wiring between the IORSM's Terminal Block Assembly and field devices (see Figure 2-8). Use AWG 14 or smaller wire (consult with the field device manufacturer for recommendations). Leave some slack and plan for wire routing, identification, maintenance, etc. The bundled wires are to be routed out through the bottom of the IORSM Assembly between the Terminal Block Assembly and the Terminal Housing Assembly.

For IORSM that are equipped with a Remote Terminal Block Assembly, install the cables between the IORS Module's Terminal Block Assembly and the DIN-rail mounted Terminal Block Assembly. Install the field wiring between the DIN-rail mounted Terminal Block Assembly and field devices (see Figures 2-9, 2-11, 2-12, 2-17, 2-18, 2-20, 2-24 & 2-28). Use AWG 14 or smaller wire (consult with the field device manufacturer for recommendations). Leave some slack and plan for wire routing, identification, maintenance, etc. The cables that run between the I/O Module and the DIN-Rail mountable Terminal Blocks are to be routed out through the bottom of the IORSM Assembly between the Header Block and the Terminal Housing Assembly. To provide access to the Header Block's lower ¼ Turn Fastener, cables associated with connectors P3 and P4 should be secured via a Tie Wrap to the lower left side of the Header Block Assembly, while cables associated with connectors P1 and P2 should be secured to the lower right side of the Header Block Assembly via a second Tie Wrap (see Figure 2-9).

Refer to the following sections for I/O Module wiring information:

- Section 2.3.2.4 = DI Module
- Section 2.3.2.5 = DO Module
- Section 2.3.2.6 = AI Module
- Section 2.3.2.7 = AO Module
- Section 2.3.2.8 = UDI Module

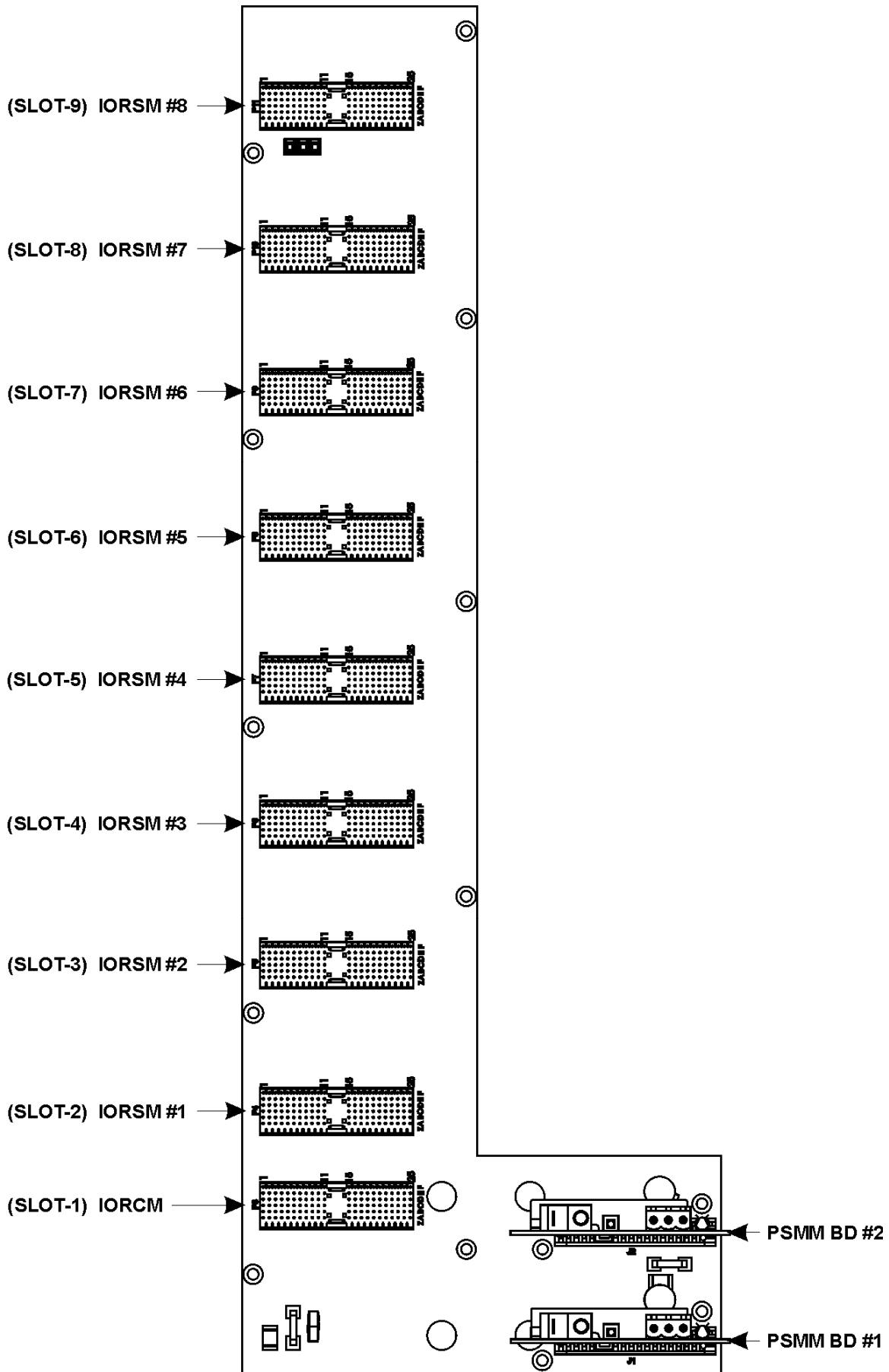

Figure 2-6 - CWREDIO Backplane Slot Assignments (PSMMs Installed)

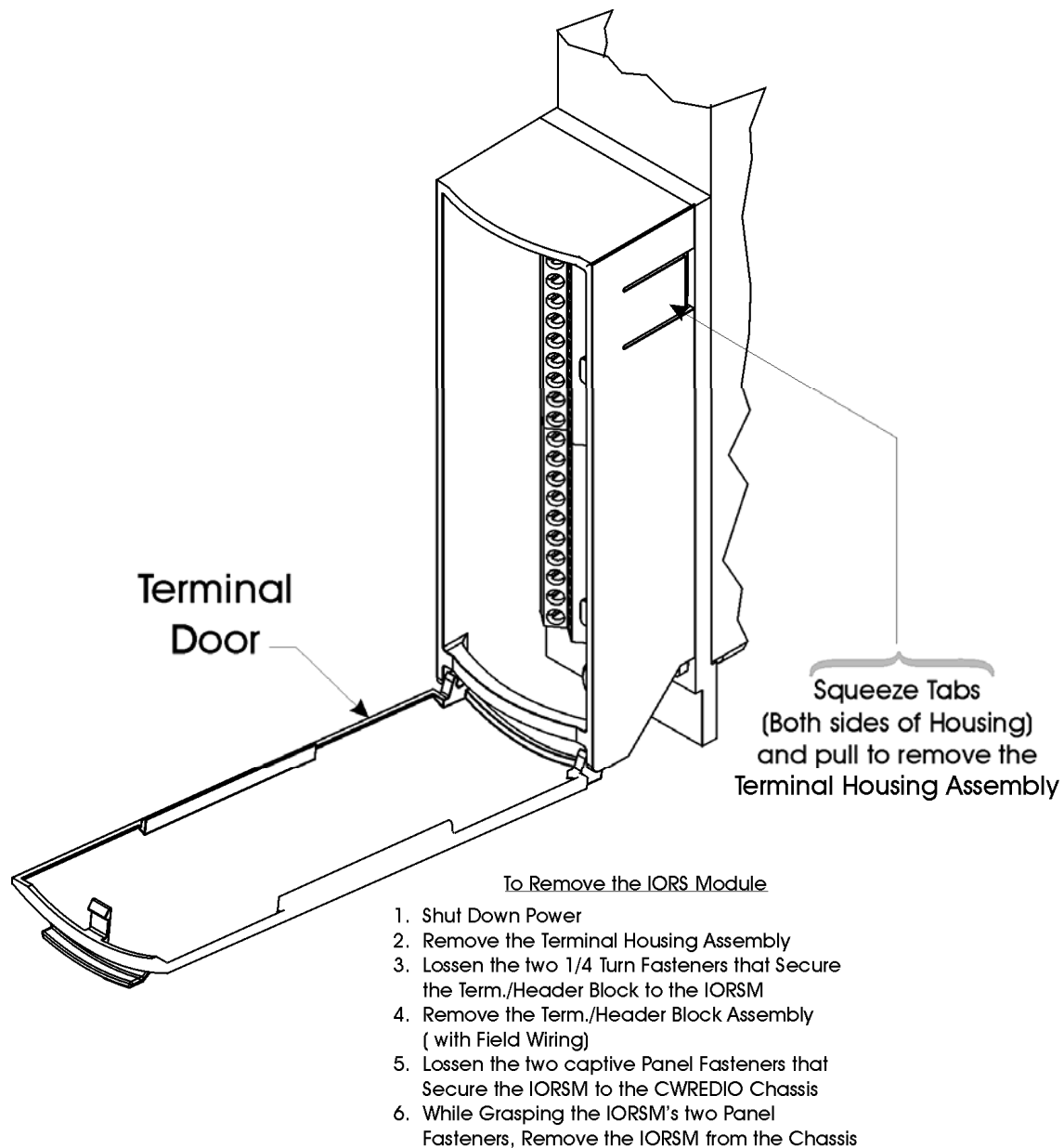

Figure 2-7 - Terminal Housing Assembly Removal

4. Align the IORSM with the assigned I/O Slot and install the unit into the Chassis. When the assembly is fully seated, turn the IORSM's Captured Panel Fasteners (clockwise) to secure the unit to the Chassis thus establishing a low resistance path between the IORSM and Chassis Ground.
5. Install the Local or Remote Terminal Block Assembly (with wiring harness) onto the IORSM (turning the Quarter Turn Fasteners (clockwise)).
6. Replace the module's Terminal Housing Assembly. **Note: Door Labels are available as MS Word files that can be typeset by the user to provide wiring identification for I/O Modules. These labels are available on the Bristol Babcock Web site www.controlwave.com and can be affixed to the inside of the Term. Housing's Door.**
7. Using a PC equipped with 'ControlWave Designer' and 'OpenBSI' software, configure CW_A/CWEXP_A & CW_B/CWEXP_B to accept the new I/O Module (and any other modules that have been added or removed) and then download the application load into the ControlWave/ControlWaveEXP CPU's System FLASH and/or SDRAM (see Section 2.4.1). For new installations, this step can be skipped until the unit has been wired and power applied.

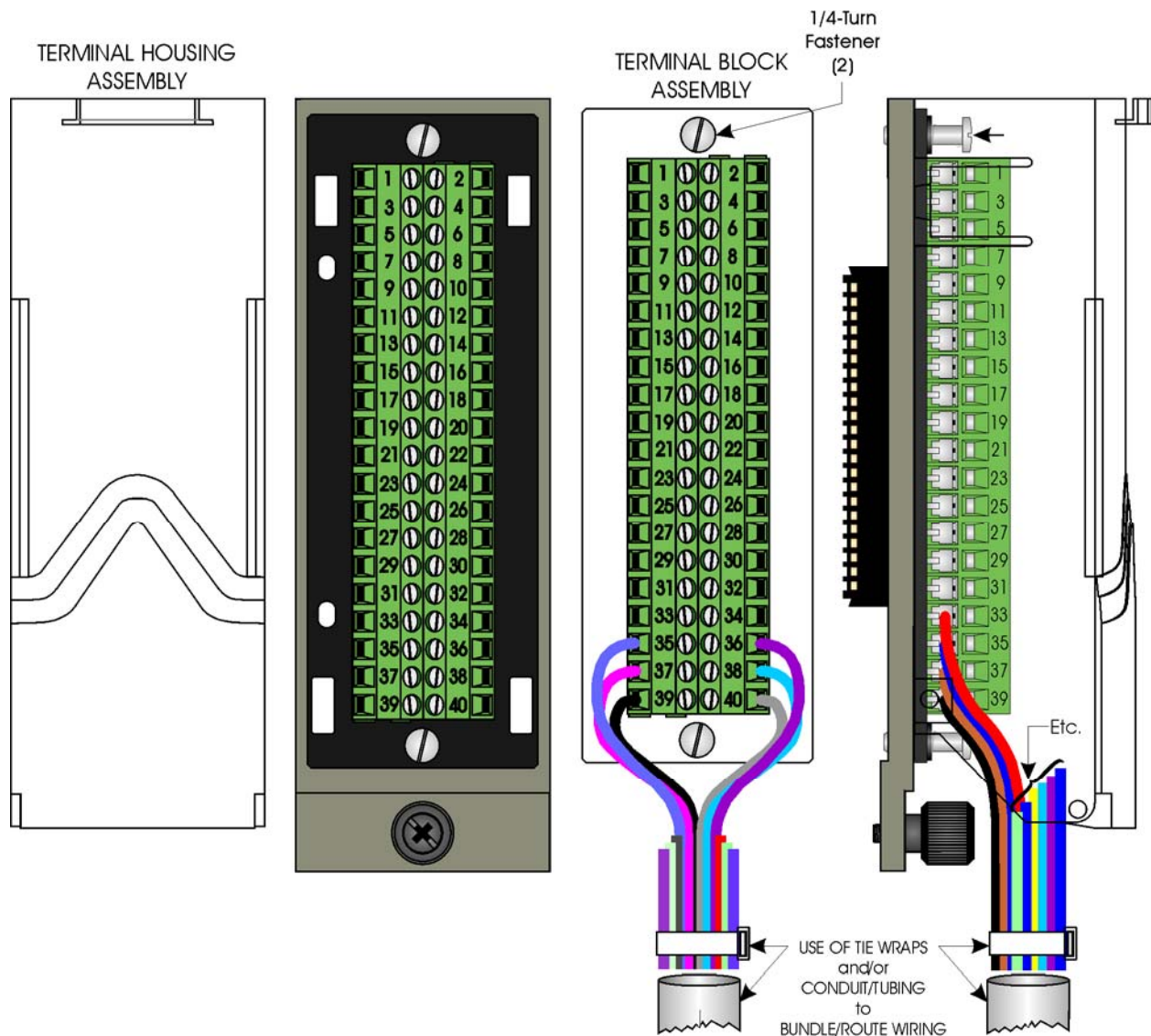

Figure 2-8 - IORSM (Local Termination) Wire Routing

2.3.2.2 Wire Connections

ControlWave Redundant I/O and Communication Switch Units utilize compression-type terminals that accommodate up to #14 AWG wire. A connection is made by inserting the wire's bared end (1/4" max) into the clamp beneath the screw and securing the screw. The wire should be inserted fully so that no bare wires are exposed to cause shorts. If using standard wire, tin the bare end with solder to prevent flattening and improve conductivity.

Allow some slack in the wires when making terminal connections. The slack makes the connections more manageable and minimizes mechanical strain on the terminal blocks.

2.3.2.3 Shielding and Grounding

The use of twisted-pair, shielded and insulated cable for I/O signal wiring will minimize signal errors caused by electromagnetic interference (EMI), radio frequency interference (RFI) and transients. When using shielded cable, all shields should only be grounded at one point in the appropriate system. This is necessary to prevent circulating ground current loops that can cause signal errors.

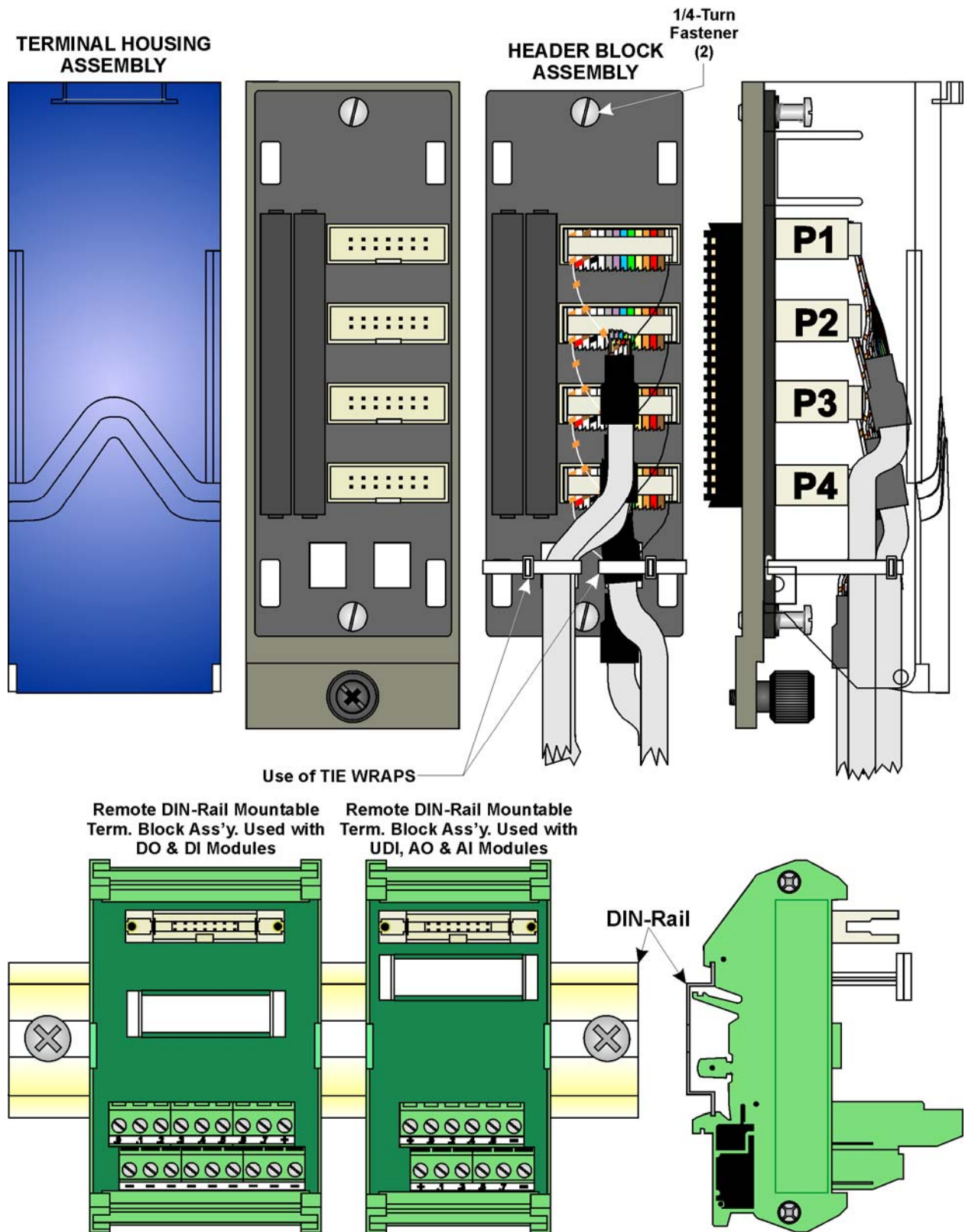

Figure 2-9 - IORSM (Remote Termination) Wire Routing

2.3.2.4 Digital Inputs (see Figures 2-10, 2-11, 2-12, 2-13 & 2-14)

ControlWave Digital Input (DI) Modules are factory-configured to support either externally powered source or dry contact DI applications. Each module contains field interface circuitry for up to 32 or 16 discrete inputs with an input range of 24Vdc, a

nominal input current is 5mA and 30 millisecond input filtering. DI Modules used in conjunction with the Local I/O Redundancy System or I/O Expansion Rack Redundancy System consists of a Header Block Assembly (remote), a Digital Input PCB, an LED PCB, an LED Housing Assembly, a Terminal Housing Assembly, as well as I/O assembly and mounting hardware.

DI field circuitry is electrically isolated from the module's bus interface circuitry by surge suppressors and optocouplers. Modules configured for use in dry contact applications contain a 21Vdc power supply. The 21Vdc field supply is derived from a control circuit and an isolated power supply that is powered by the output of the hot swap control circuit, which in turn is powered by the +VIN/-VIN supply interfaced from the **ControlWave's/ControlWaveEXP's** Backplane.

Each DI PCB is connected to its associated Header Block Assembly via a 44-pin header and to the **ControlWave's/ControlWaveEXP's** Backplane via a 110-pin connector.

2.3.2.4.1 Digital Input Configurations

Digital Input Modules are factory configured to support either 32/16 externally sourced DIs or 32/16 internally sourced DIs. Modules configured for use in dry contact applications contain a 21Vdc power supply. The nominal input voltage is 24Vdc @ 5mA.

Field wiring assignments associated with the locally terminated DIRS Modules and remotely terminated DIRS Modules are provided in Figures 2-10 and 2-11 respectively. A special remote termination module with built-in discrete relay module that supports input from 120Vac DIs is also available (see Figure 2-12). The special remote termination module (with built-in discrete relay module) is interfaced to an externally sourced DI Module.

Terminal Block Assembly Assignments for DI Operation

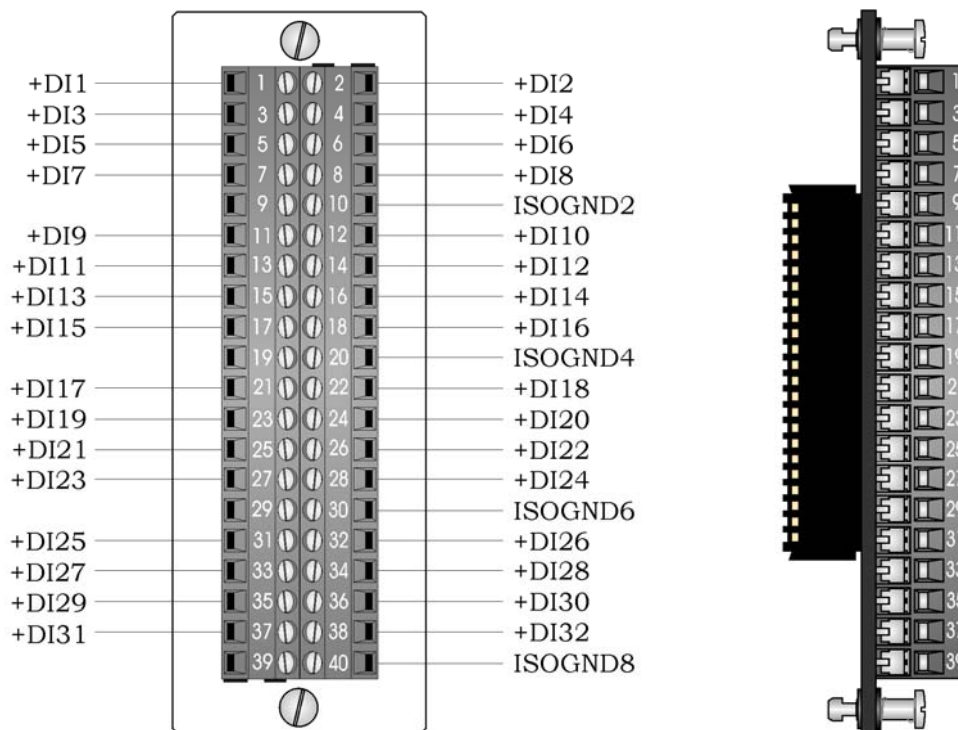

**Figure 2-10 - Local Terminal Block Assembly Assignments
for Internally Sourced DI Operation or Externally Powered DI Operation**

Cable Assembly (One of 2 or 4 Cables)

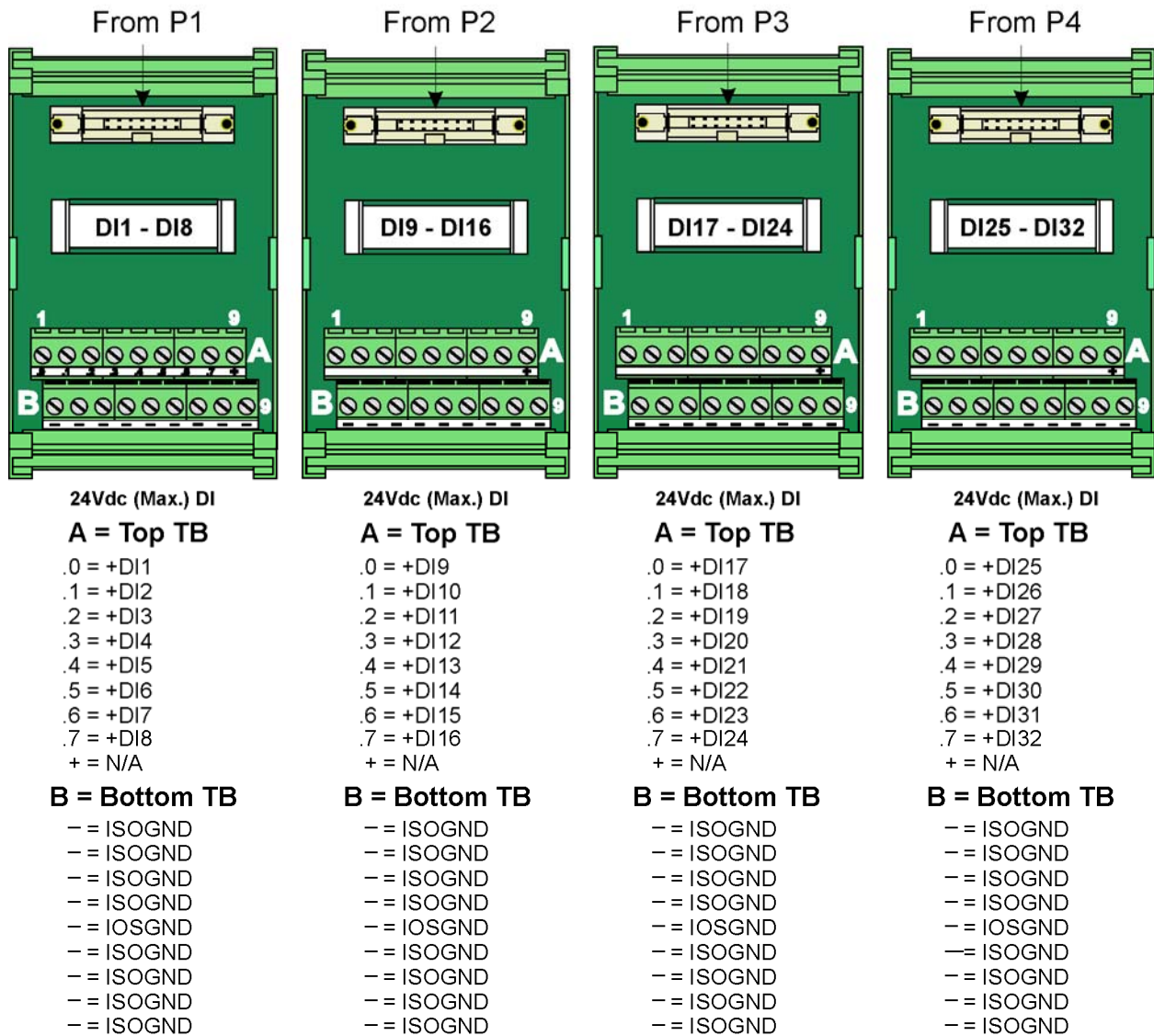
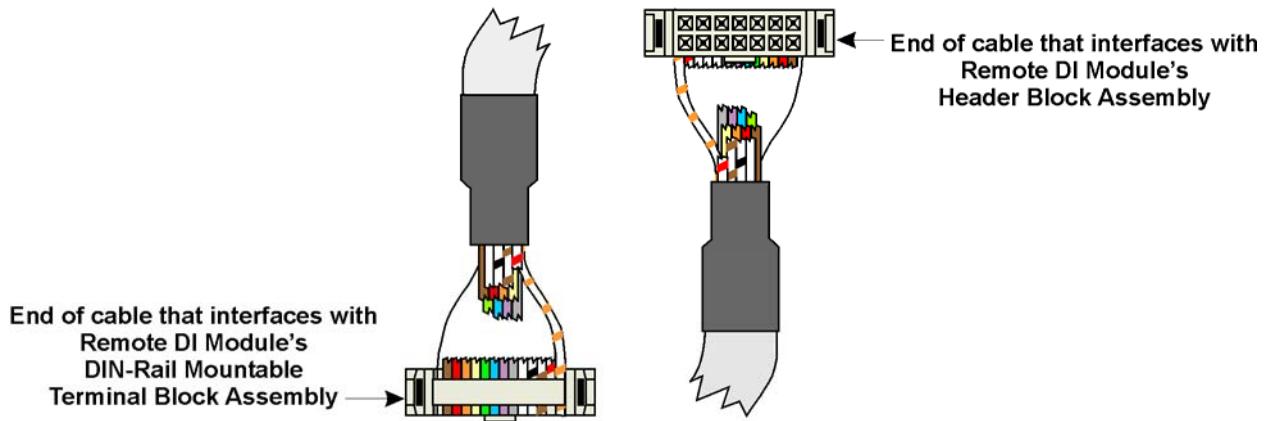

Figure 2-11 - Remote DIN-Rail Mountable Terminal Block Assembly Assignments for Internally Sourced DI Operation or Externally Powered DI Operation

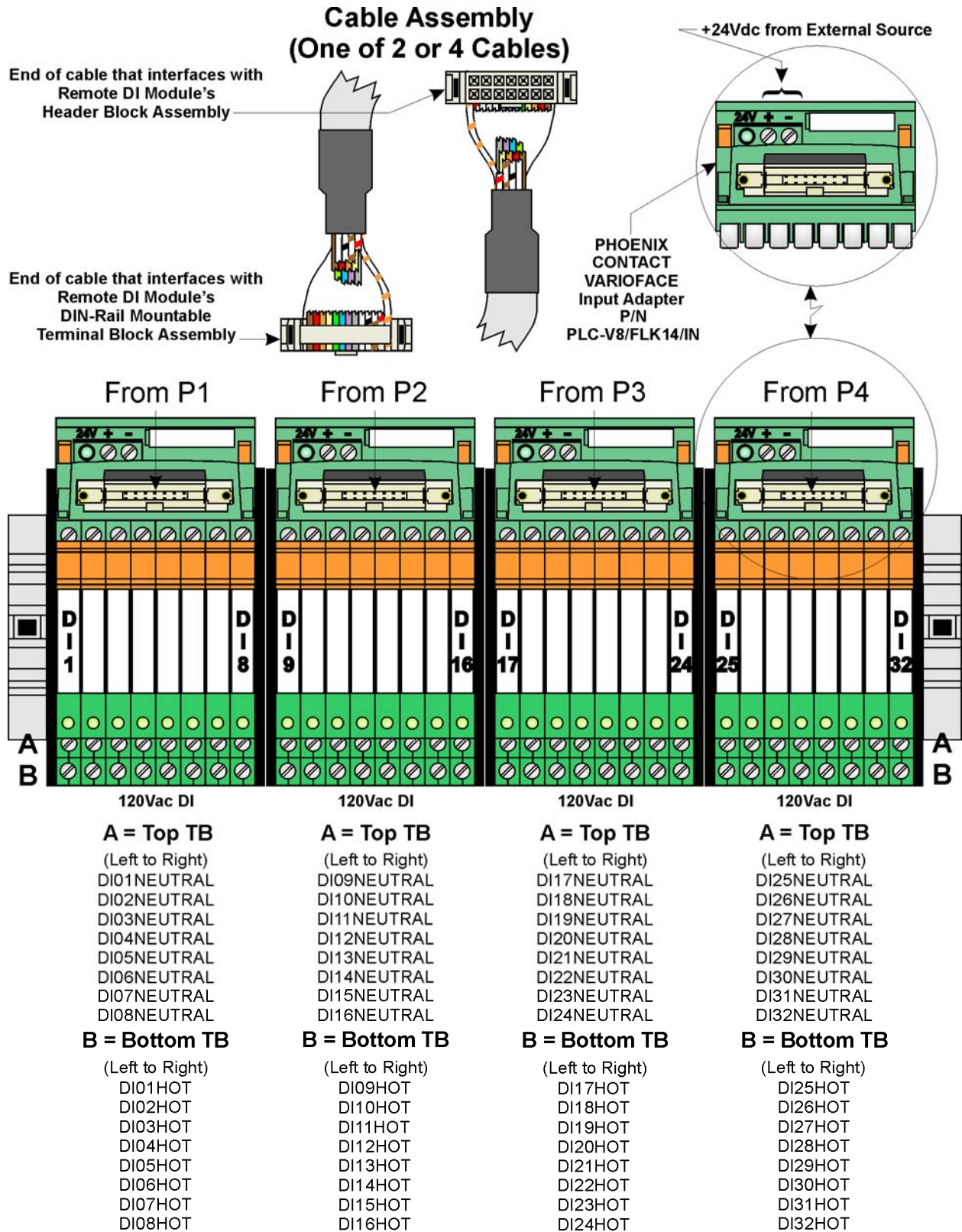

Figure 2-12 - Remote DIN-Rail Mountable Terminal Block Assembly Assignments for Relay Isolated 120Vac DI Operation

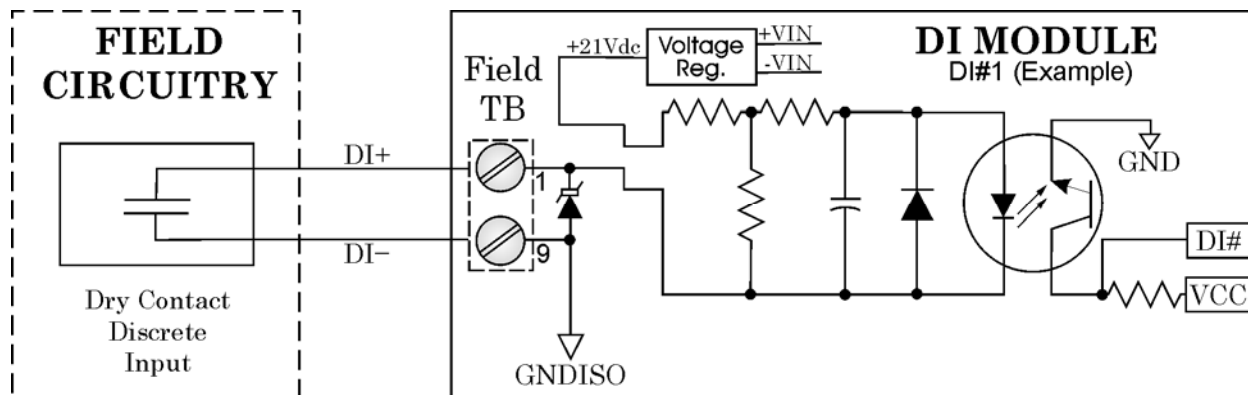

Figure 2-13 - Internally Sourced DI Module - Wiring Diagram

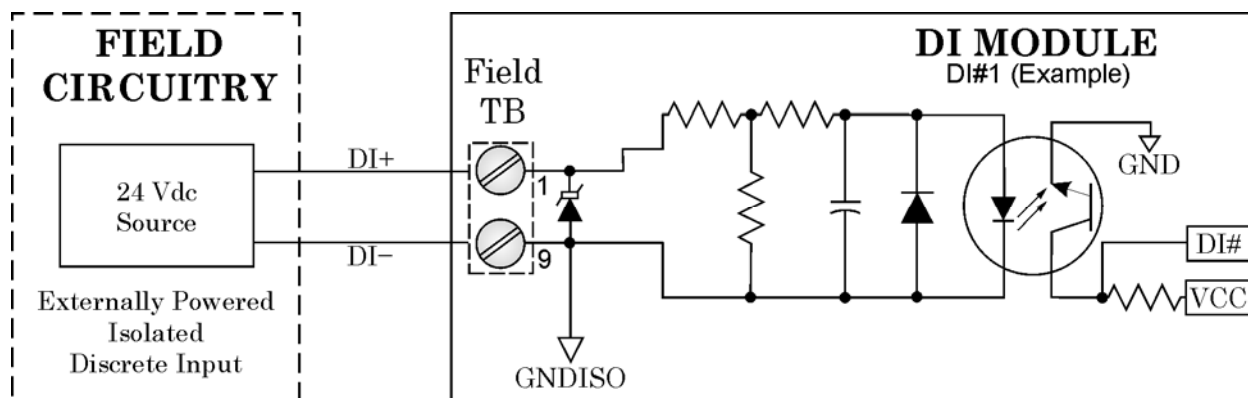

Figure 2-14 - Externally Powered DI Module - Wiring Diagram

2.3.2.5 Digital Outputs (see Figures 2-15, 2-16, 2-17 & 2-18)

ControlWave Digital Output (DO) Modules provide a total of 32 or 16 DOs for control of signaling functions. Each output contains an optically isolated open source MOSFET and surge suppressor that are capable of handling 500mA @ 31V. **ControlWave** DO Modules used in conjunction with the Local I/O Redundancy System or I/O Expansion Rack Redundancy System consists of a Header Block Assembly (remote), a Discrete Input PCB, an LED PCB, an LED Housing Assembly, a Terminal Housing Assembly, as well as I/O assembly and mounting hardware.

DO field circuitry MOSFETs are electrically isolated from the module's bus interface circuitry by surge suppressors and optocouplers.

Output data is stored in an on board DO Load Register. Upon power up the DO Load register is cleared and all outputs are set "off."

Each DO PCB is connected to its associated Header Block Assembly via a 44-pin header and to the **ControlWave's/ControlWaveEXP's** Backplane via a 110-pin connector.

2.3.2.5.1 Digital Output Configurations

Digital Output Modules provide a total of 32 or 16 DOs with surge protection. Each DO utilizes an open source MOSFET that is capable of driving up to 31Vdc at up to 500mA. A 500Vdc MOV to Chassis and a 31Vdc Transorb (across output) are provided to protect each DO. The maximum operating frequency is 20 Hz.

Field wiring assignments associated with the locally terminated DORS Modules and remotely terminated DORS Modules are provided in Figures 2-15 and 2-17 respectively. A special remote termination module with built-in discrete relay modules is also available (see Figure 2-18).

Terminal Block Assembly Assignments for DO Operation

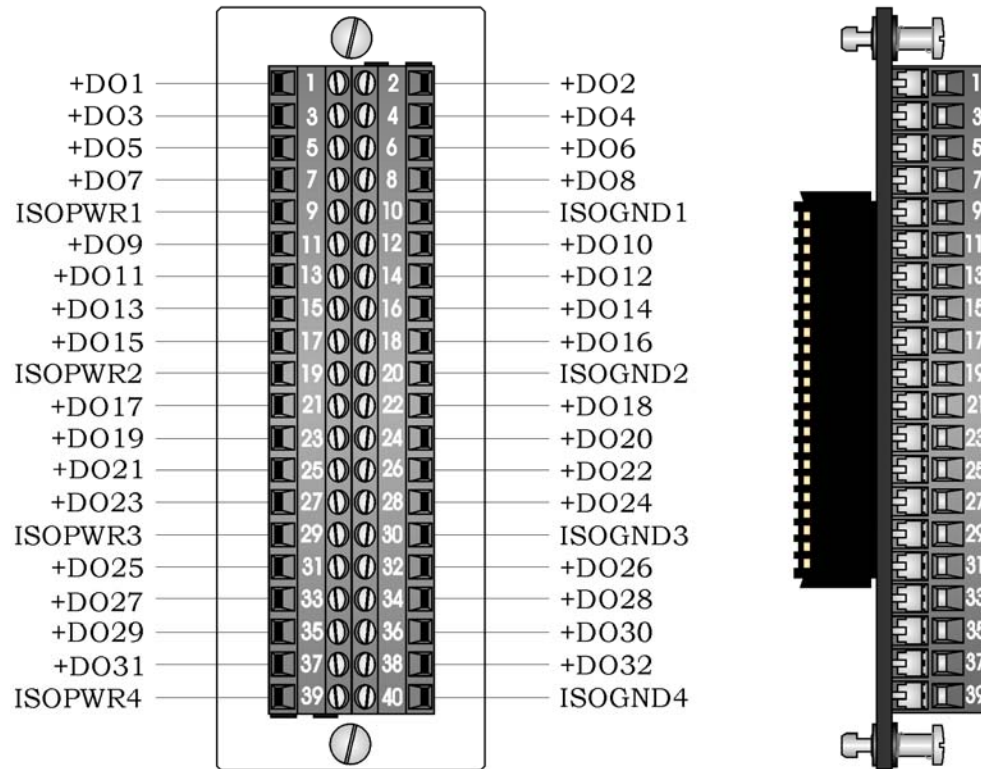

Figure 2-15 - Local Terminal Block Assembly Assignments for Open Source Isolated DO Operation

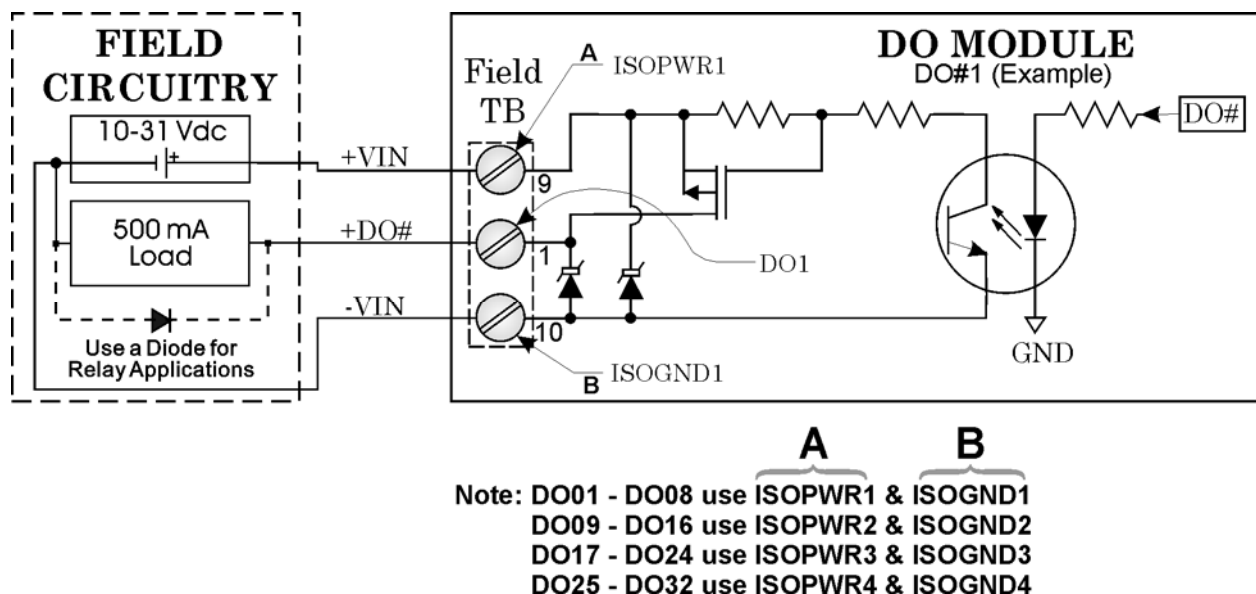

Figure 2-16 - Open Source Isolated DO Module - Wiring Diagram

Cable Assembly (One of 2 or 4 Cables)

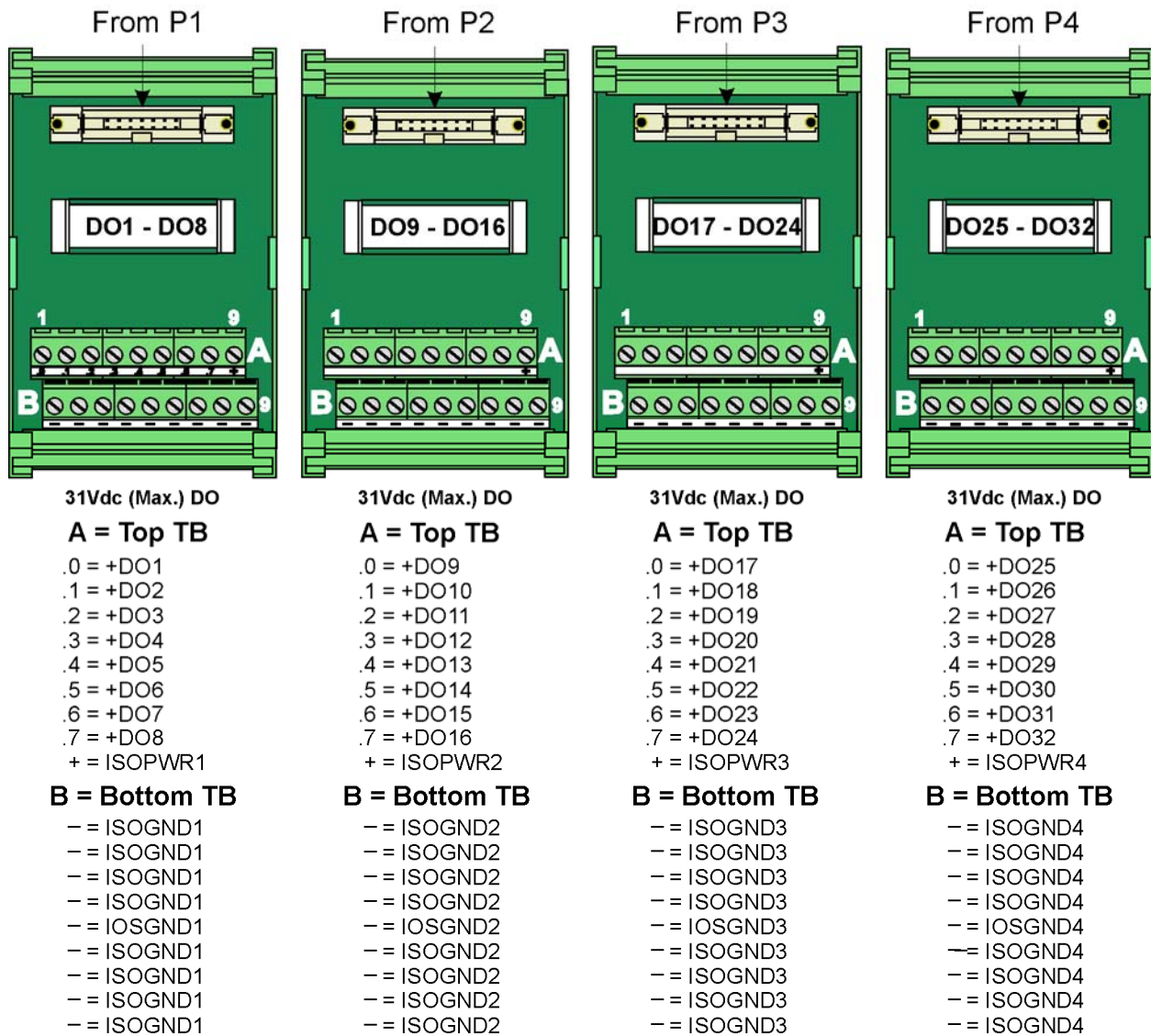
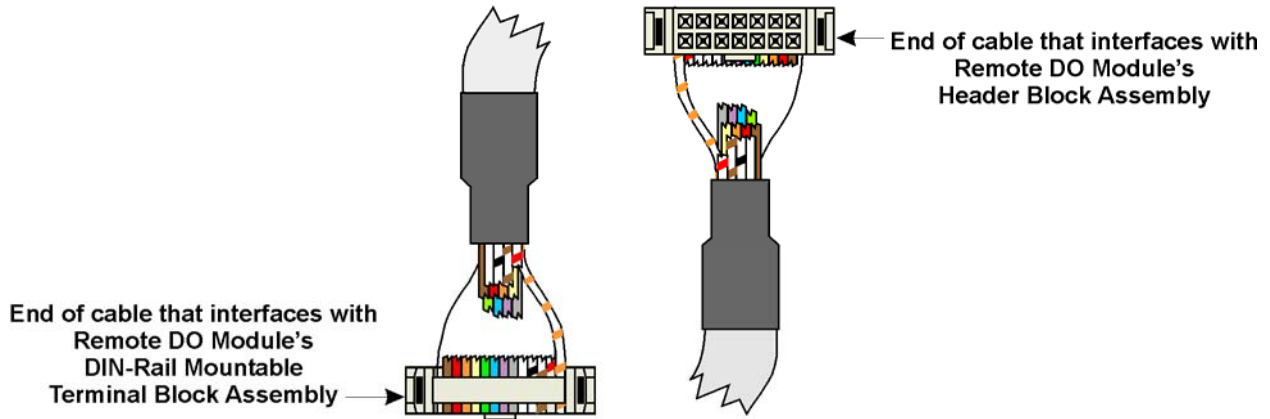

Figure 2-17 - Remote DIN-Rail Mountable Terminal Block Assembly Assignments for Open Source Isolated DO Operation

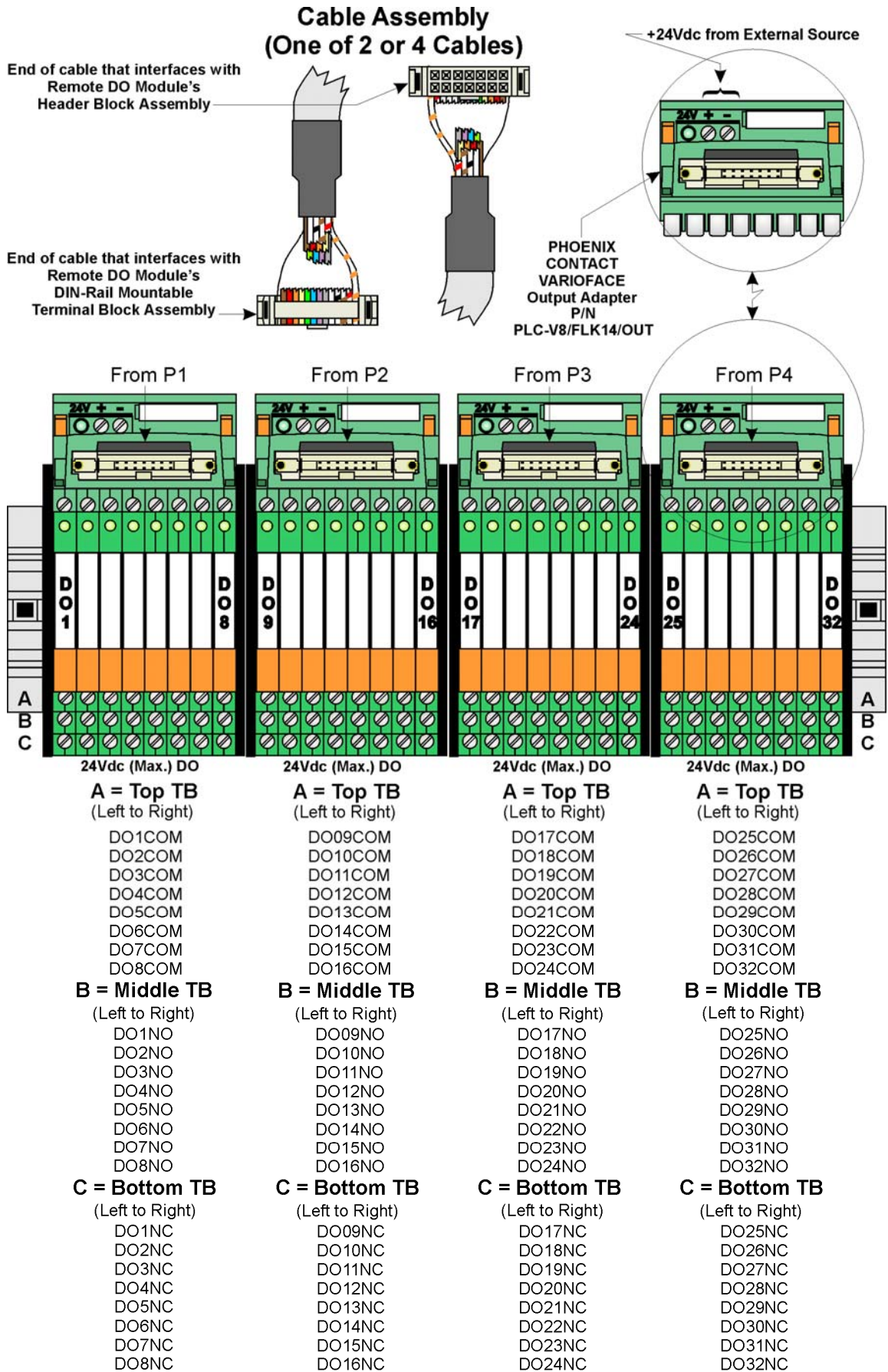

Figure 2-18 - Remote DIN-Rail Mountable Terminal Block Assembly Assignments for Relay Isolated 24Vdc DO Operation

2.3.2.6 Analog Inputs (see Figures 2-19 through 2-22)

Although the AIRSM supports connection to externally powered 4-20mA or 1-5 Vdc AIs, only 1-5 Vdc type **ControlWave** AI Modules are supported by **ControlWave** Redundant I/O and Communications Switch Units. The AIRSM that supports 4-20mA is similar to the 1-5V AIRSM but includes a discrete 250-ohm resistor across each input pair. The 250-ohm resistor converts the 4-20mA input signal to a 1-5V signal. **ControlWave** 1-5V AI Modules used in conjunction with Local I/O Redundancy System or I/O Expansion Rack Redundancy System consists of a Header Block Assembly (remote), an Analog Input PCB, an LED PCB, an LED Housing Assembly, a Terminal Housing Assembly, as well as I/O assembly and mounting hardware. Each Analog Input Module contains field interface circuitry for up to 16 or 8 analog inputs.

AI circuitry is electrically isolated from the module's bus interface circuitry. On the isolated side each AI signal is channeled through signal conditioning, surge suppression, multiplexing and a 14-bit A to D converter. The bus interface circuitry consists of the control logic to access A to D converters and multiplexers, static RAM (to store the latest 14-bit digitized data for each of the sixteen channels and the on board reference voltages) and control logic to access the system bus.

The common mode range for 1-5V Analog Inputs is 31Vdc. For 4-20 mA Analog Inputs, all inputs are referenced to the -AI the module. Each AI PCB is connected to its associated Header Block Assembly via a 44-pin header and to the **ControlWave's/ControlWaveEXP** Backplane via a 110-pin connector.

Terminal Block Assembly Assignments for AI Operation

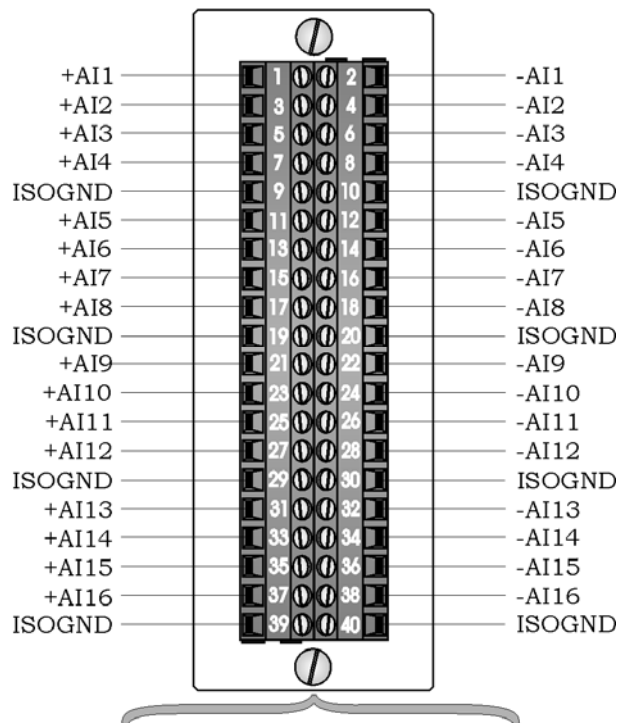

Note 1:
Pins, 9, 10, 19, 20, 29, 30, 39 & 40
= ISOGND

Figure 2-19 - Local AI Module Terminal Block Assembly Assignments

2.3.2.6.1 Analog Input Configurations

ControlWave AI Modules (with either 16 or 8 AI) are offered with 1-5V isolated inputs.

Field wiring assignments associated with the locally terminated AIRSM are provided in Figure 2-19. Field wiring assignments associated with remotely terminated AIRSMs are provided in Figure 2-20.

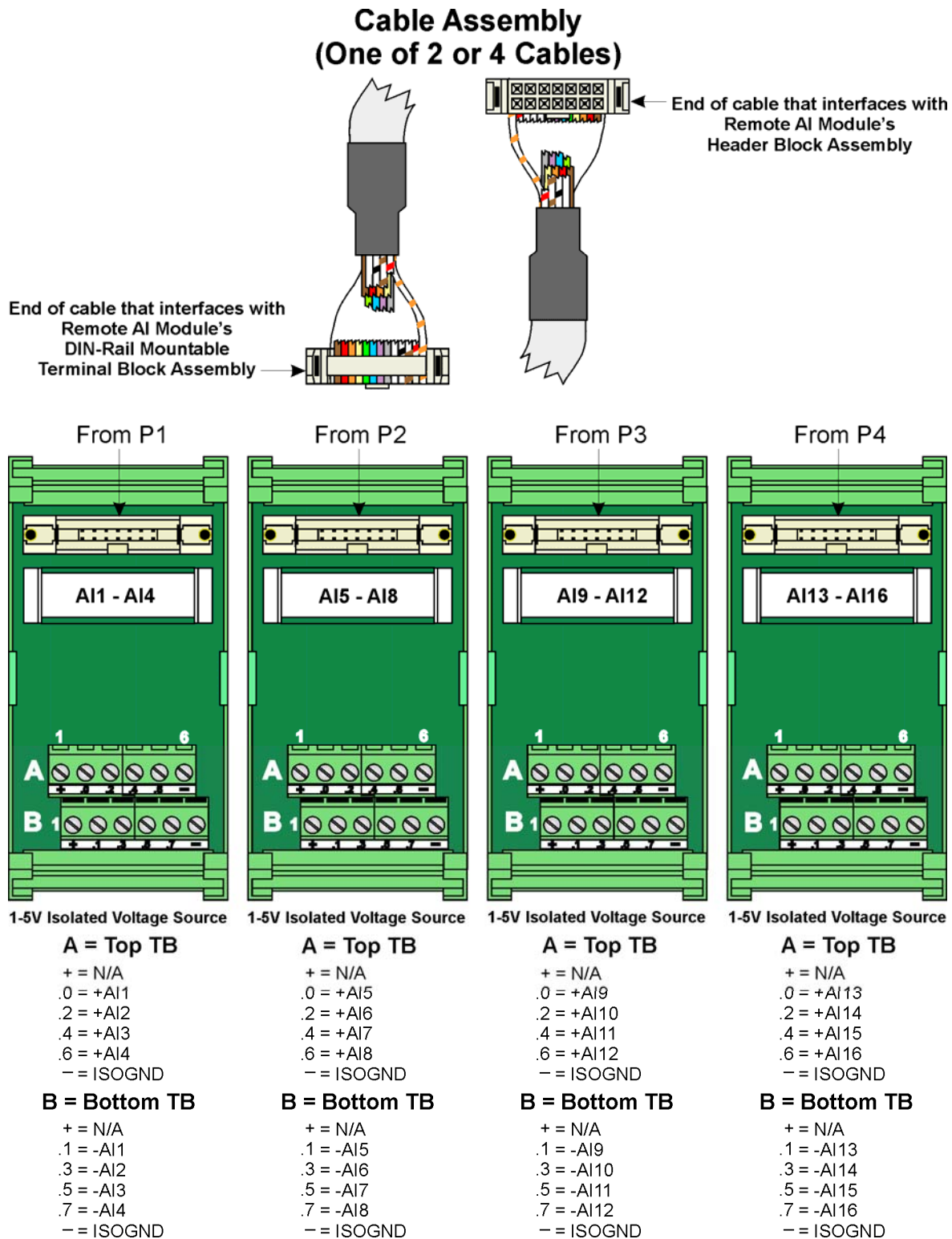

Figure 2-20 - Remote DIN-Rail Mountable Terminal Block Assembly Assignments for 1-5V or 4-20mA AI Operation

Note:

Cable shields associated with AI wiring should be connected to the ControlWave Chassis Ground. Multiple shield terminations will require a user supplied copper ground bus. This ground bus must be connected to the ControlWave's Chassis Ground Lug (using up to a #4 AWG wire size) and must accommodate a connection to a known good Earth Ground (in lieu of a direct connection from the Ground Lug) and to all AI cable shields. Shield wires should use an appropriate Term. Lug and should be secured to the copper bus via industry rugged hardware (screw/bolt, lockwasher and nuts).

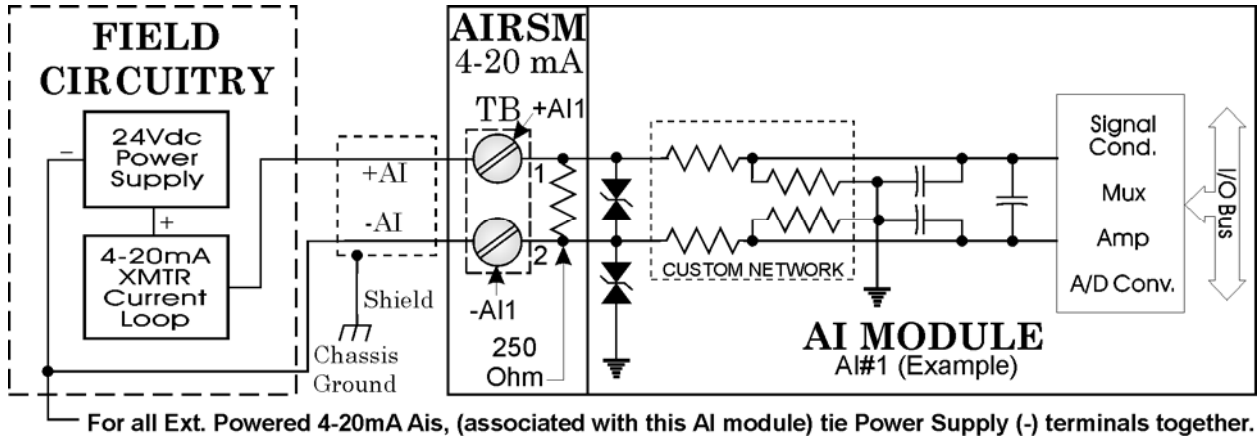

Figure 2-21 - Externally Powered 4-20mA Current Loop AI - Wiring Diagram

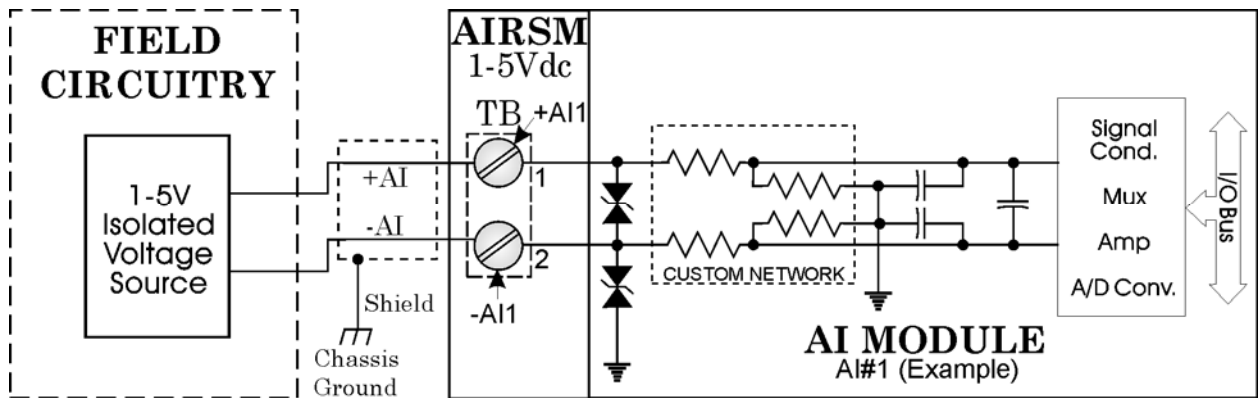

Figure 2-22 - Externally Powered Isolated 1-5 Volt AI - Wiring Diagram

2.3.2.7 Analog Outputs (see Figures 2-23 through 2-26)

ControlWave AO Modules are factory configured to support either 4-20mA or 1-5 Vdc analog outputs. Each module contains field interface circuitry for up to 8 or 4 analog outputs. Each AO Module used in conjunction with the Local I/O Redundancy System or I/O Expansion Rack Redundancy System consists of a Header Block Assembly (remote), an Analog Output PCB (with a daughter board when configured for 1-5V operation), an LED PCB, an LED Housing Assembly, a Terminal Housing Assembly, as well as I/O assembly and mounting hardware.

AO circuitry is electrically isolated from the module's bus interface circuitry. On the isolated side, each AO signal passes through one of two, 4-channel digital to analog converters (DAC) that drive voltage to current converters. The V to I circuits are powered by an on board isolated 19V power supply and the DACs are powered by an isolated 5V supply. Outputs are protected from transients with surge suppressors. Each AO PCB is connected

to its associated Header Block Assembly via a 44-pin header and to the **ControlWave's/ControlWaveEXP's** Backplane via a 110-pin connector.

The maximum external load that can be connected to the 4-20mA output is 650 ohms. The maximum external load current for the 1-5V output is 5mA. An additional error (associated with the voltage output mode) is caused by the voltage drop across an inductor. This error is not compensated and is equal to the output current times two inductor resistances, e.g., 2.5 ohms x 2 x .005A = 25mV (or 0.625% of span).

2.3.2.7.1 Analog Output Configurations

ControlWave Analog Output Modules are factory configured to support either eight (8) 1-5V or 4-20mA isolated outputs. Field wiring assignments associated with the locally terminated AORS Modules are provided in Figures 2-23 while wiring assignments associated with the remotely terminated AORS Modules are provided in Figure 2-24.

Terminal Block Assembly Assignments for AO Operation

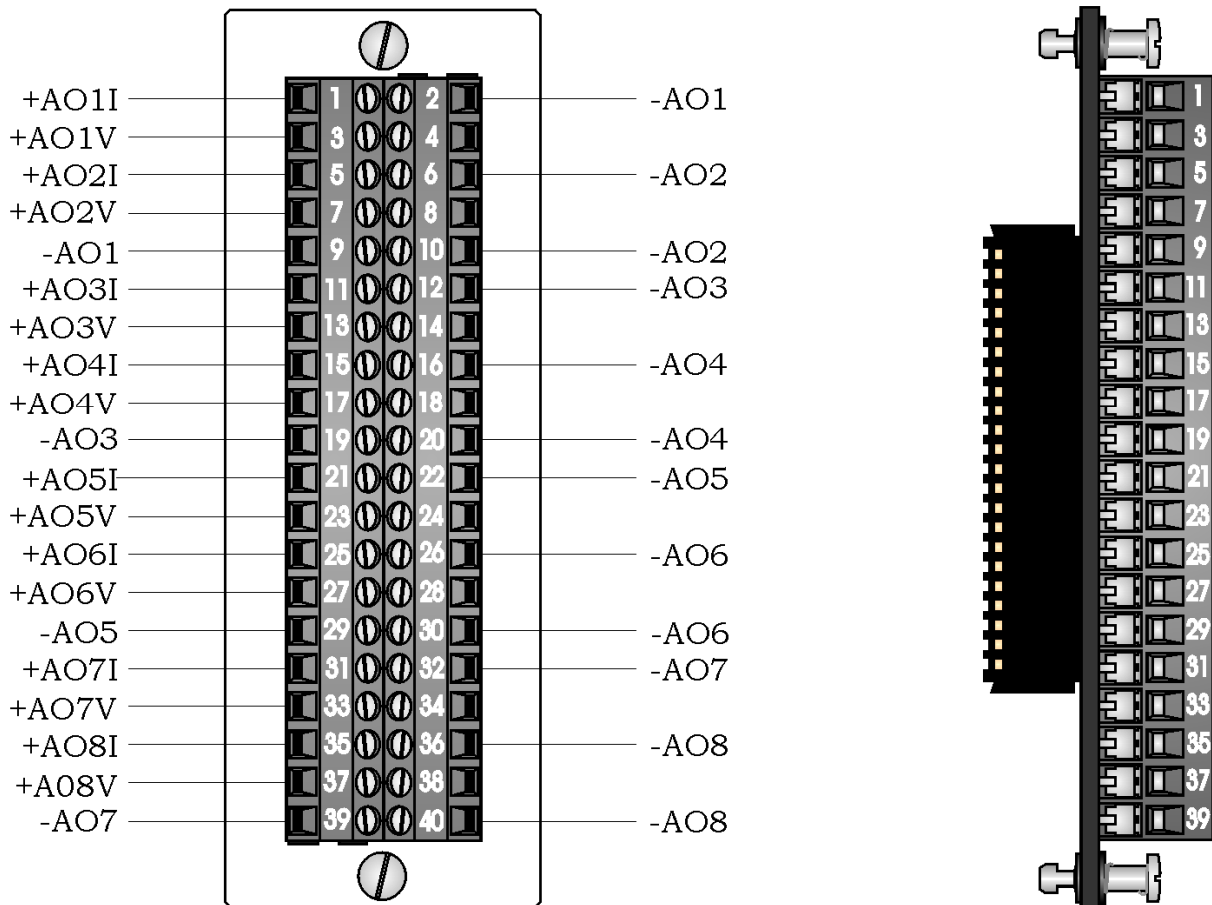

Figure 2-23 - Local AO Module Terminal Blocks Assembly Assignments

Cable Assembly (One of 2 or 4 Cables)

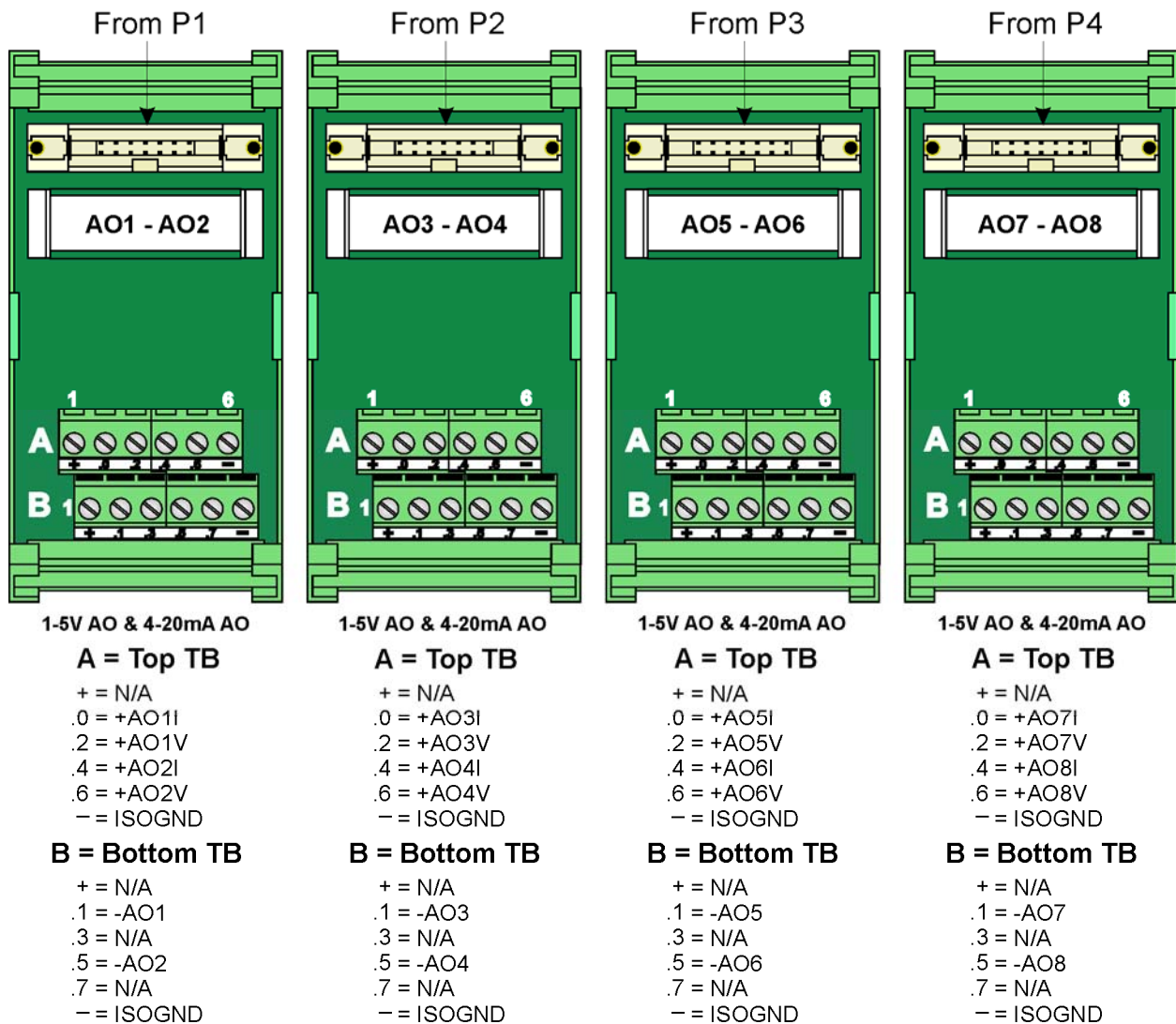
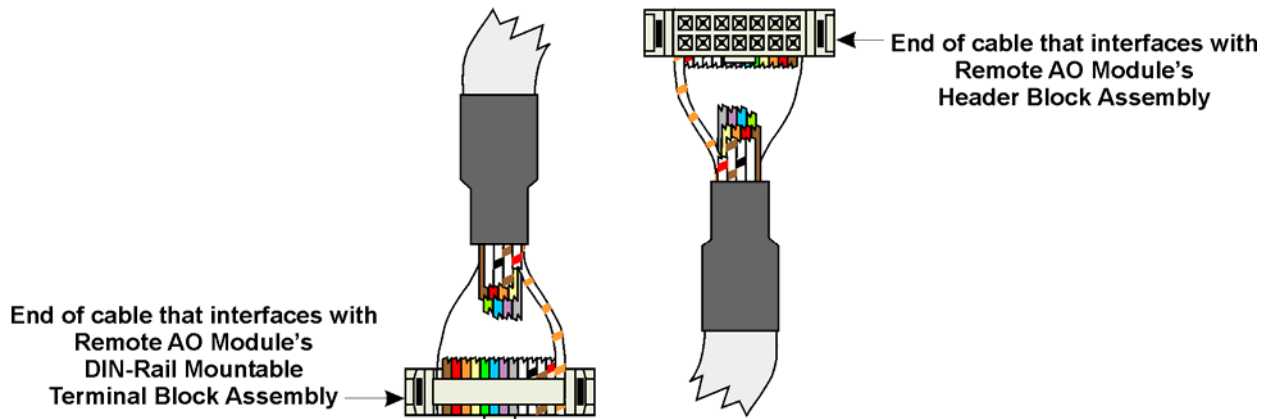

Figure 2-24 - Remote DIN-Rail Mountable Terminal Block Assembly Assignments for AO 4-20mA and 1-5V Operation

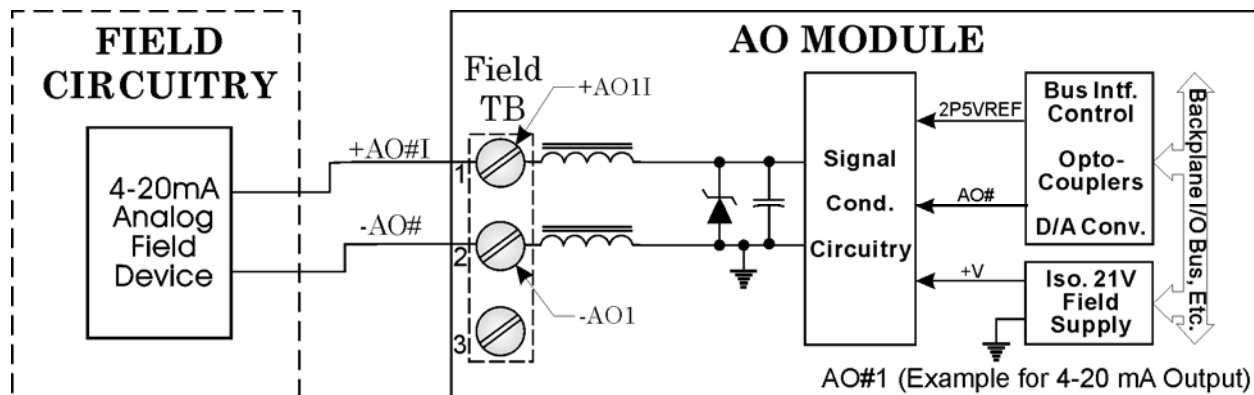

Figure 2-25 - 4-20mA Current Loop AO - Wiring Diagrams

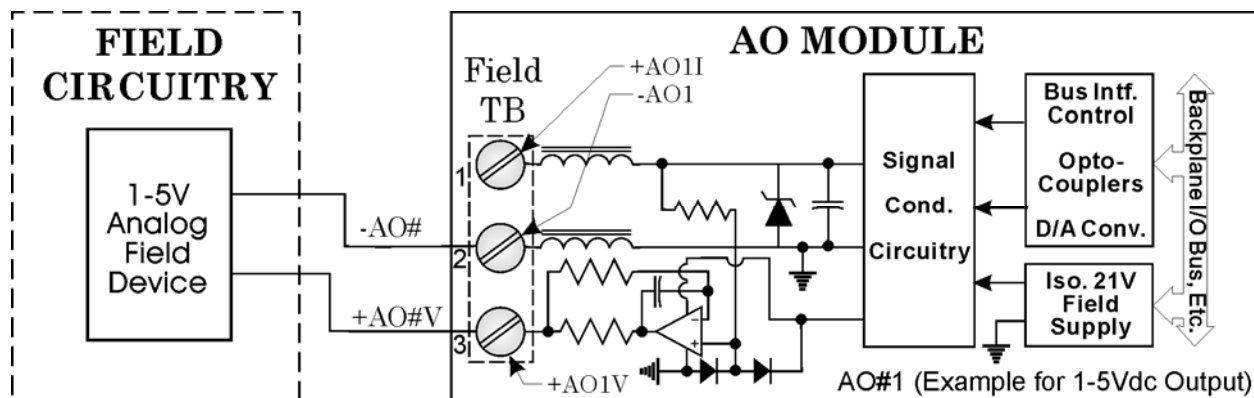

Figure 2-26 - 1-5Vdc Voltage AO - Wiring Diagrams

2.3.2.8 Universal Digital Input Modules (see Figures 2-27 through 3-30)

ControlWave Universal Digital Input (UDI) Modules provide a total of 12 or 6 inputs. Each input is optically isolated from the field device. UDI Module inputs are factory configured with all inputs set with debounce enabled or with all inputs set with debounce disabled. With debounce enabled, spurious pulses caused by relay contact bounce are reduced with filters. Individual UDI inputs can be customer configured for a polled input or totalizer operation. Field inputs can be driven signals, open collector outputs or relay contacts. The maximum input frequency is 10 kHz. For any input used as a totalizer, the maximum totalized count before rollover is 65535 and the totalizer is not resettable through software. UDI Modules used in conjunction with the Local I/O Redundancy System or I/O Expansion Rack Redundancy System consists of a Header Block Assembly (remote), a Universal Input PCB, an LED PCB, an LED Housing Assembly, a Terminal Housing Assembly, as well as I/O assembly and mounting hardware.

ControlWave Universal Digital Input Module circuitry consists of signal conditioning circuitry, 4-bit accumulators and a microcontroller. Signal conditioning circuitry includes optocouplers, debounce circuitry and bandwidth limit circuitry. The microcontroller monitors the inputs and maintains delays for each input that has been configured to be polled.

Each input of the UDI Module can be configured as a polled input and/or as a low speed or high speed counter.

UDI circuits with debounce disabled have two field inputs, SET and COM. When the debounce circuitry is enabled (factory), a change of state on both the SET and RESET field inputs is required to accumulate counts. The maximum input frequency is 10 kHz with a nominal input current of 5mA.

Delay registers for signal conditioning allow individual inputs to utilize one of three software selectable delays. The 20 usec delay is used for the 10 kHz input range required for high speed counting. The 1 millisecond delay is required for low speed counter applications. 30 millisecond delays are required for general purpose inputs or contacts where contact bounce may be an issue.

2.3.2.8.1 Universal Digital Input Configurations

ControlWave UDI Modules provide a total of 12 or 6 UIs with surge protection. Each UDI Module is capable of handling 24V inputs.

Each input is provided electrical isolation of 500Vdc to Chassis and 1500Vdc to system logic. Each input is also protected with a 31dc Transorb (across input and to Field Common) that meets the ANSI/IEEE standard C37.90-1978.

Field wiring assignments associated with the locally terminated UDIRS Modules and remotely terminated UDIRS Modules are provided in Figures 2-27 and 2-28 respectively.

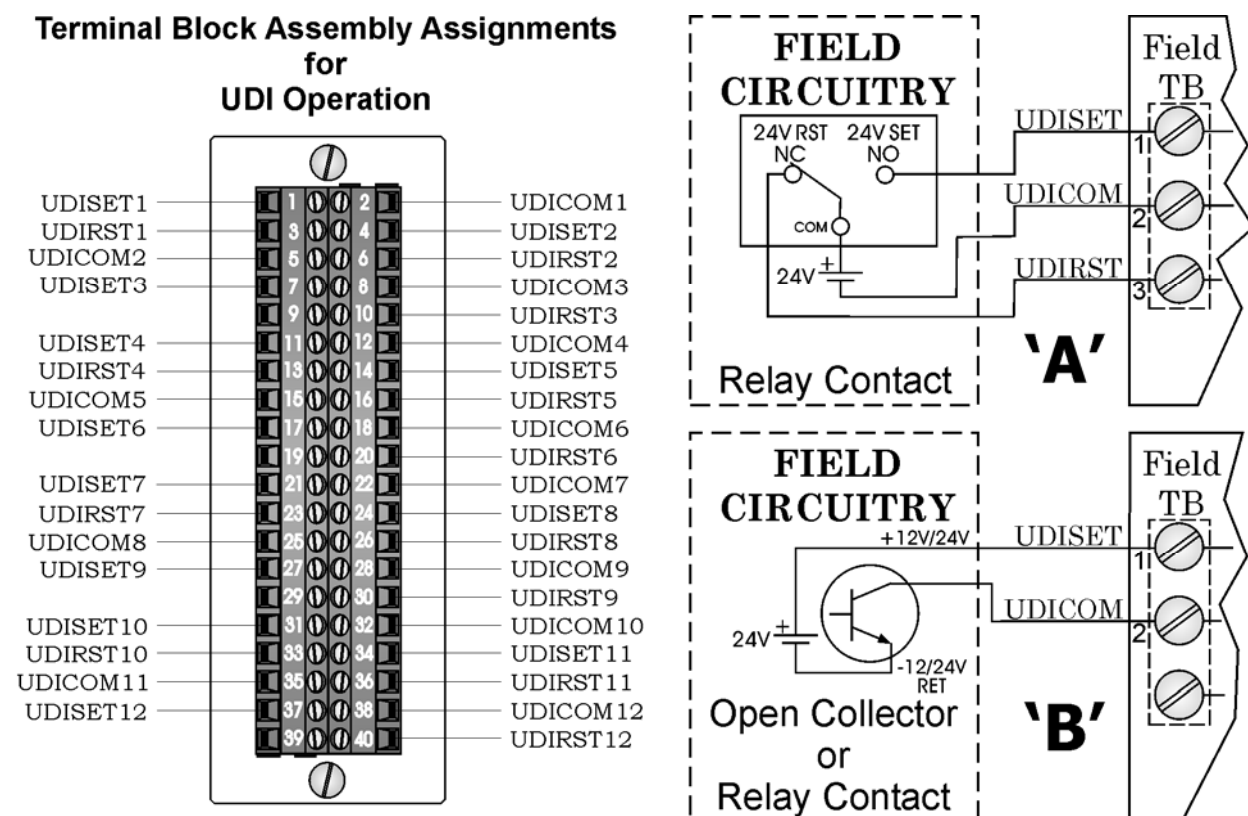

Figure 2-27 - Local UDI Terminal Block/Configuration Diagram

Cable Assembly (One of 2 or 4 Cables)

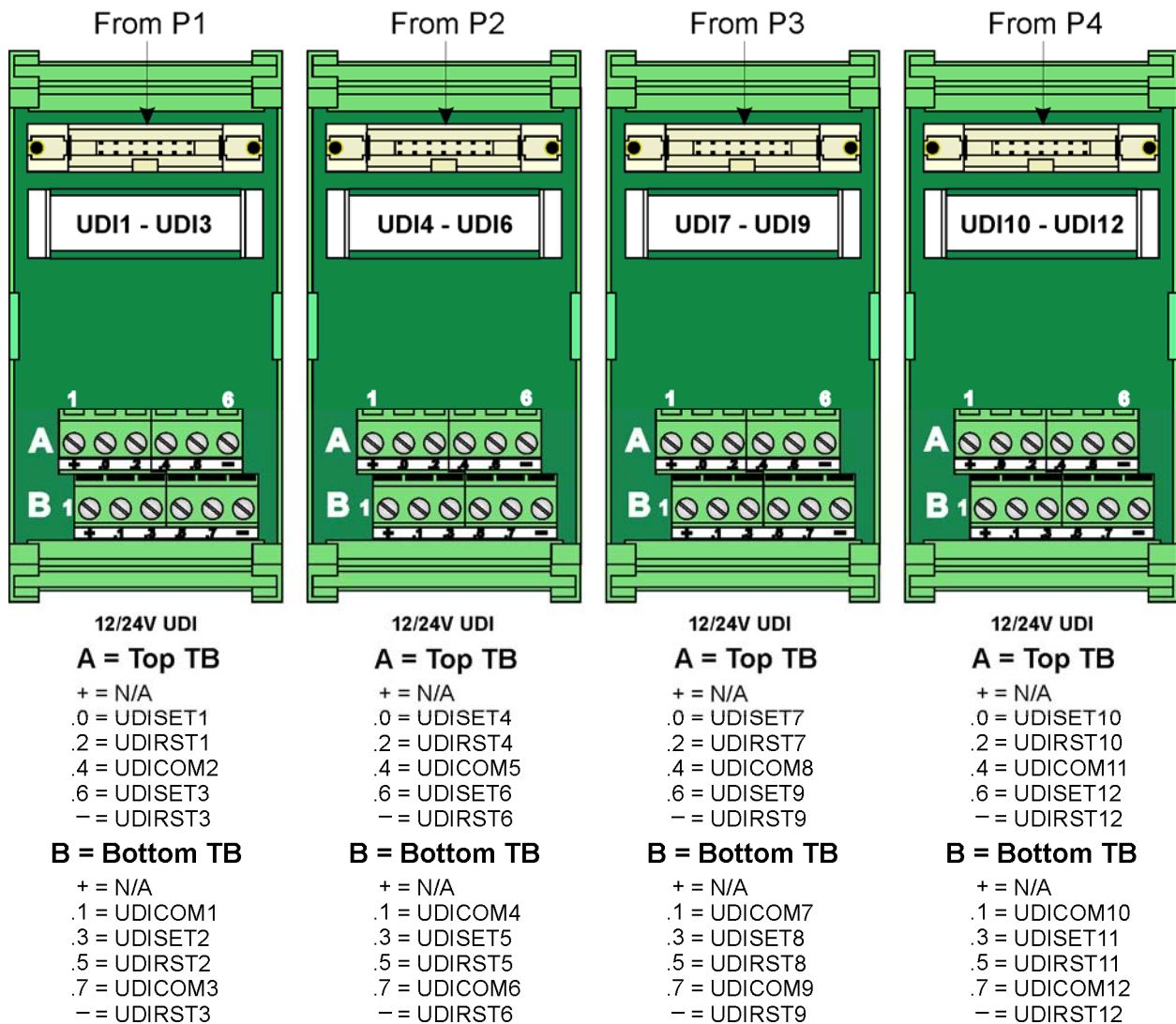
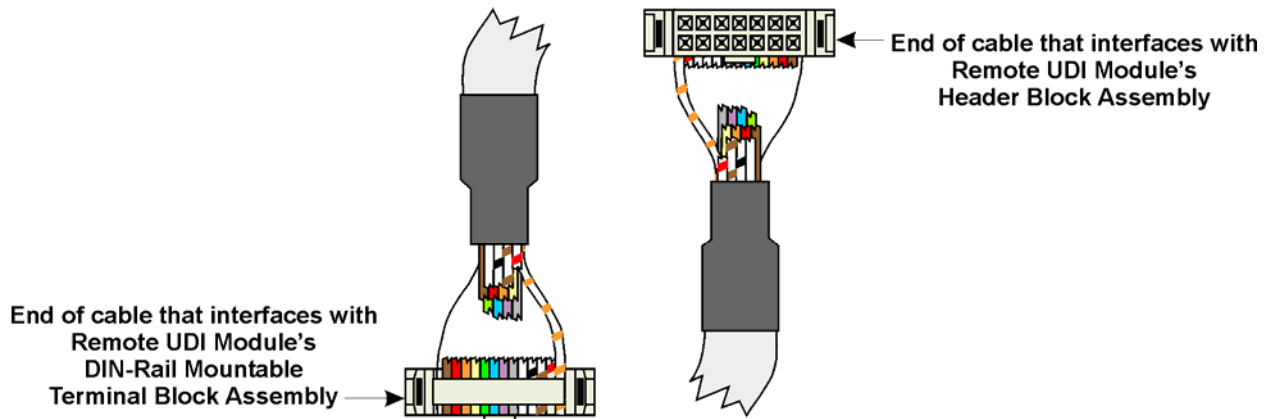

Figure 2-28 - Remote DIN-Rail Mountable Terminal Block Assembly Assignments for UDI Operation

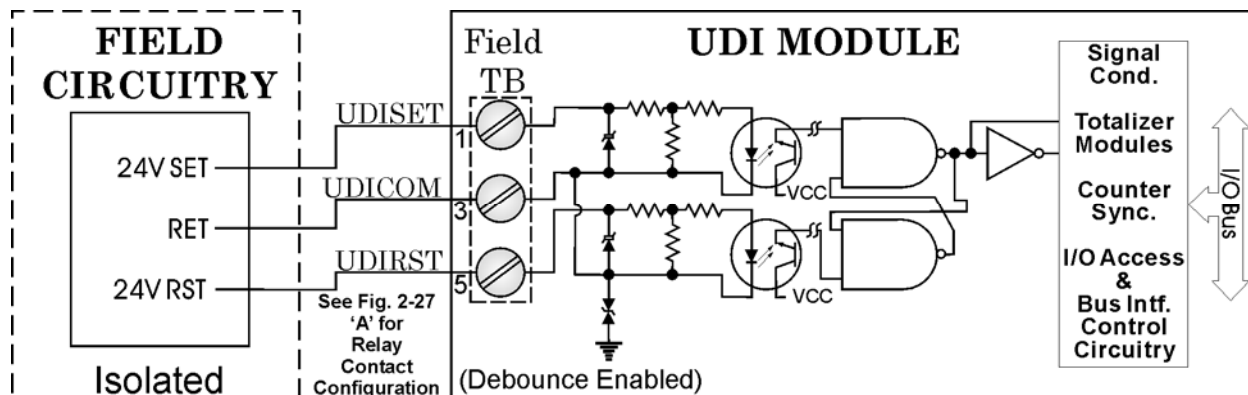

Figure 2-29 - UDI (Debounce Enabled) Wiring Diagram

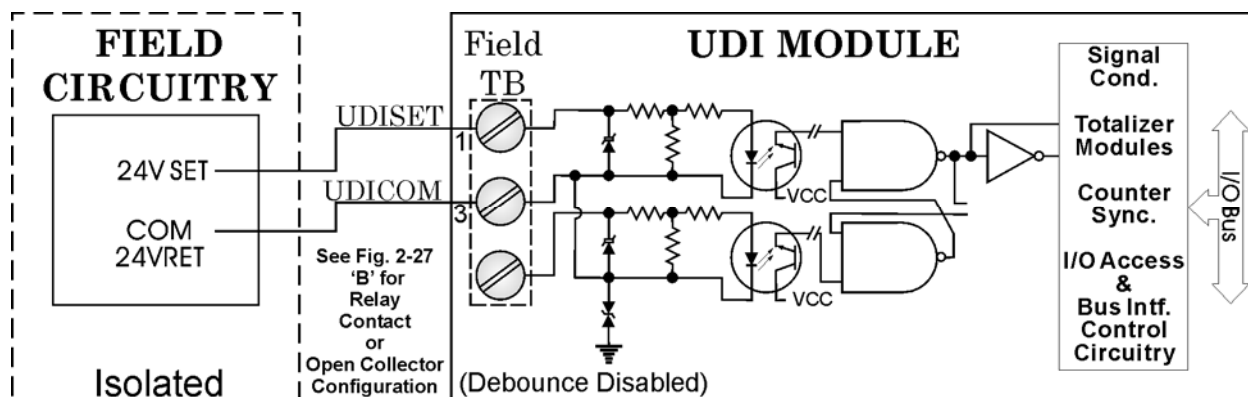

Figure 2-30 - UDI (Debounce Disabled) Wiring Diagram

2.3.3 Power Supply Wiring

ControlWave I/O Power Supply/Monitor Modules (PSMMs) utilize compression-type terminals that accommodate up to #14 AWG wire. A connection is made by inserting the wire's bared end (1/4" max) into the clamp adjacent to the screw and then securing the screw. The wire should be inserted fully so that no bare wires are exposed to cause shorts. If using standard wire, tin the bare end with solder to prevent flattening and improve conductivity.

Allow some slack in the wires when making terminal connections. The slack makes the connections more manageable and helps to minimize mechanical strain on the terminal blocks.

2.3.3.1 Bulk Power Supply Current Requirements

ControlWave Redundant I/O and Communications Switch Units (CWREDIO) are equipped with two 24Vdc **ControlWave** I/O Power Supply/Monitor Modules (PSMMs). The maximum current required for the +24Vdc bulk power supply used with a particular CWREDIO can be estimated as follows:

$$\text{Bulk +24Vdc Supply Current} = \text{System Hardware} + \text{Sum of all AORSMs and DORSMs}$$

This summation will accommodate steady state as well as power up in-rush current draw. System hardware consists of the two PSMMs, the IORCM and the Chassis assemblies. Table 2-4 provides the current requirements.

Note: When two bulk power supplies are required, the first supply (VIN) (see Fig. 2-32) must be rated to handle 2 Amps.

Table 2-4 - Current Requirements for Bulk 24Vdc Power Supply

COMPONENTS	UNIT A Master	UNIT B Master
IORCM, CHASSIS, PSMMs	185mA	256mA
AORSM	3mA	103mA
DORSM	3mA	8mA

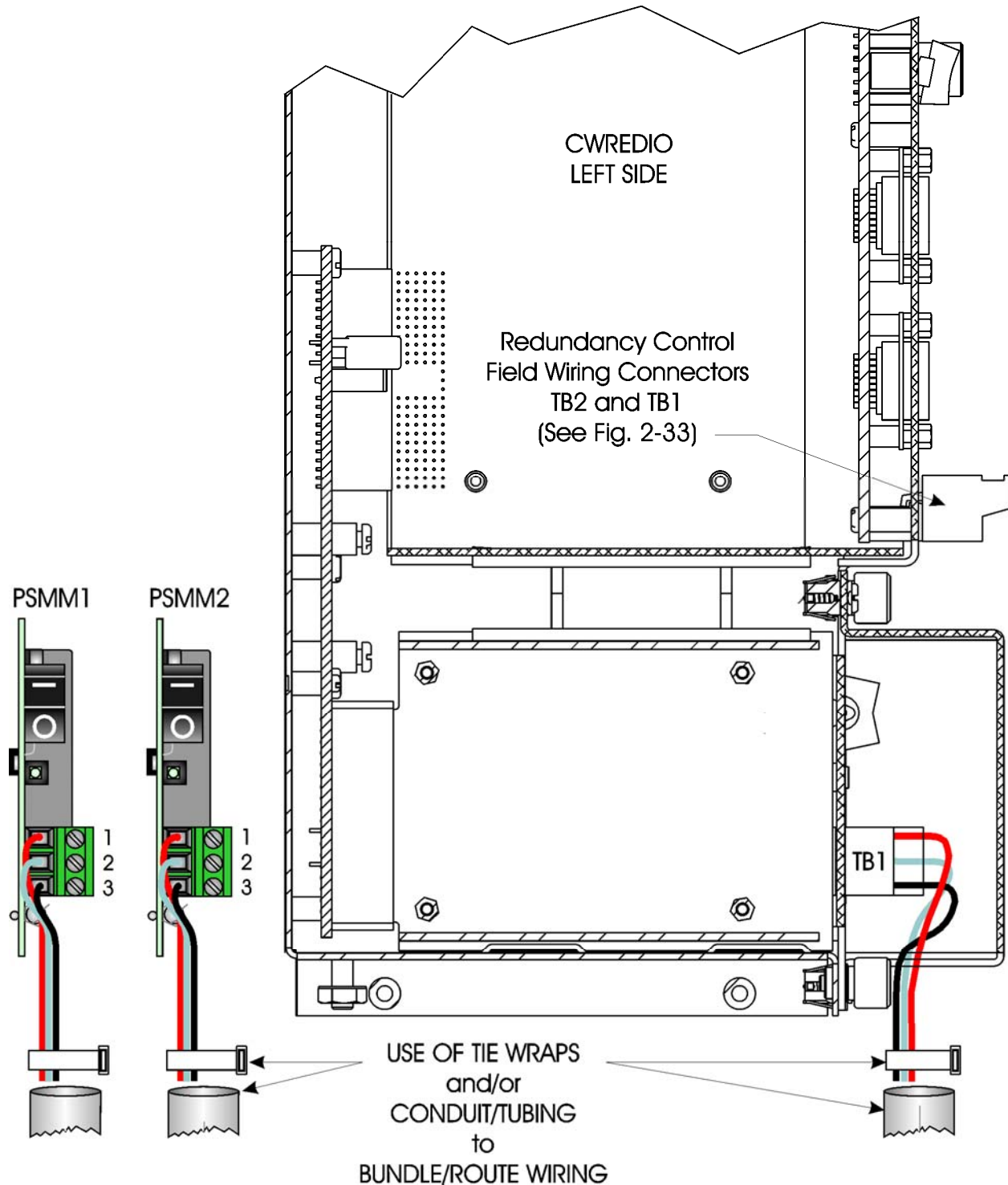

Figure 2-31 - PSMM Wire Routing Diagram

2.3.3.2 Power Wiring

DC Power is interconnected to a PSMM via Connector TB1. A discrete DC supply can be connected to each PSMM, or they may use a shared Bulk DC supply. The Bulk DC supply (nominally +24Vdc) connected to TB1-1 (+VIN) is converted, regulated and filtered by the PSMM to produce a regulated +5.2Vdc power. Each PSMM contains 5A Fuse. The bulk DC supply is connected to PSMM Terminal Block TB1-1 (+VIN) and TB1-2 (-VIN).

PSMM Connector TB1 provides 3 input connections for bulk power as follows:

- TB1-1 = (+VIN) (+20.7V to +30V dc)
- TB1-2 = (-VIN) (Supply Ground)
- TB1-3 = Chassis Ground - CHASSIS (\neq)

Typical Configurations

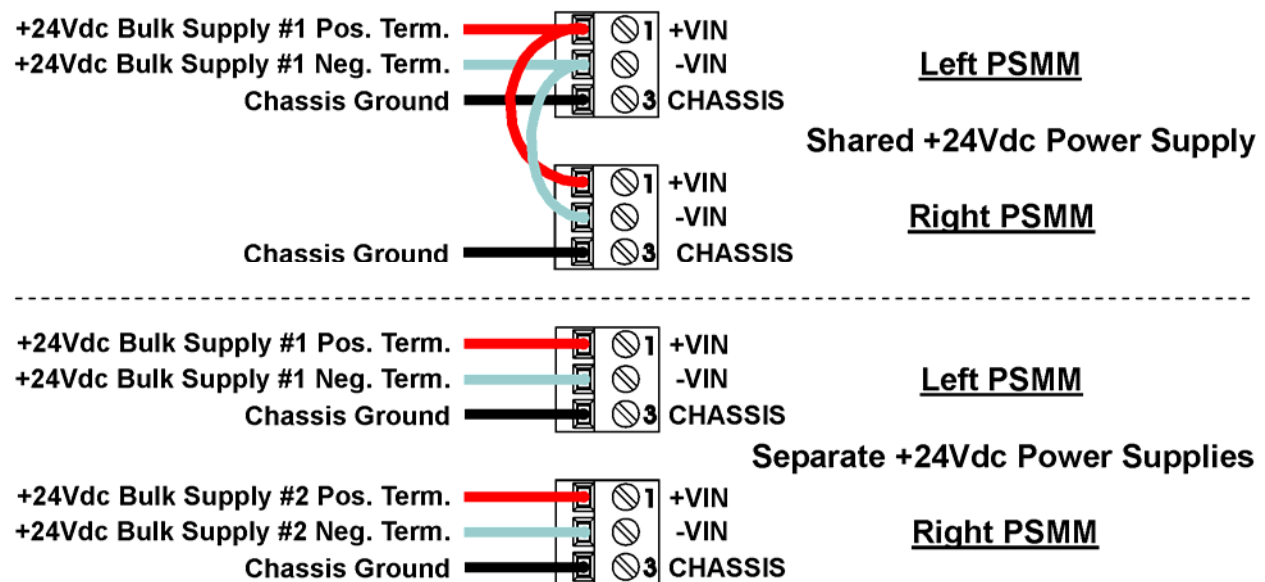

Figure 2-32 - PSMM's TB1 Typical Wiring Schemes

2.3.3.3 Redundancy Control Field Wiring (see Figure 2-33)

The circuit that drives Redundant Master Controller selection located on the I/O Redundancy Control Module (IORCM). IORCM connectors TB1 and TB2 interface to separate **ControlWaves** or **ControlWaveEXPs**. Basically the IORCM monitors the Watchdog Bad signals from Controllers A and B and in conjunction with logic associated with IORCM switches SW1 (A/B Enable Mode Key Switch) and SW2 (A/B Primary Select Switch) it provides a relay driven signal to TB1 pin-3 (VR) of the Power Supply/Sequencer Module in the selected Master **ControlWave** or **ControlWaveEXP**. *Watchdog Bad* is a signal generated by a **ControlWave** series CPU Module when its hardware detects improper software operation.

The **ControlWave** PSSM's watchdog MOSFET switch is powered via the VI input of the terminal block (TB1-2) and its switched output is connected to the VO output of the terminal block (TB1-1). The external power source connected to the VI terminal must be referenced to the return point of the input source that powers the PSMM [-VIN or PSGND (TB2-3)].

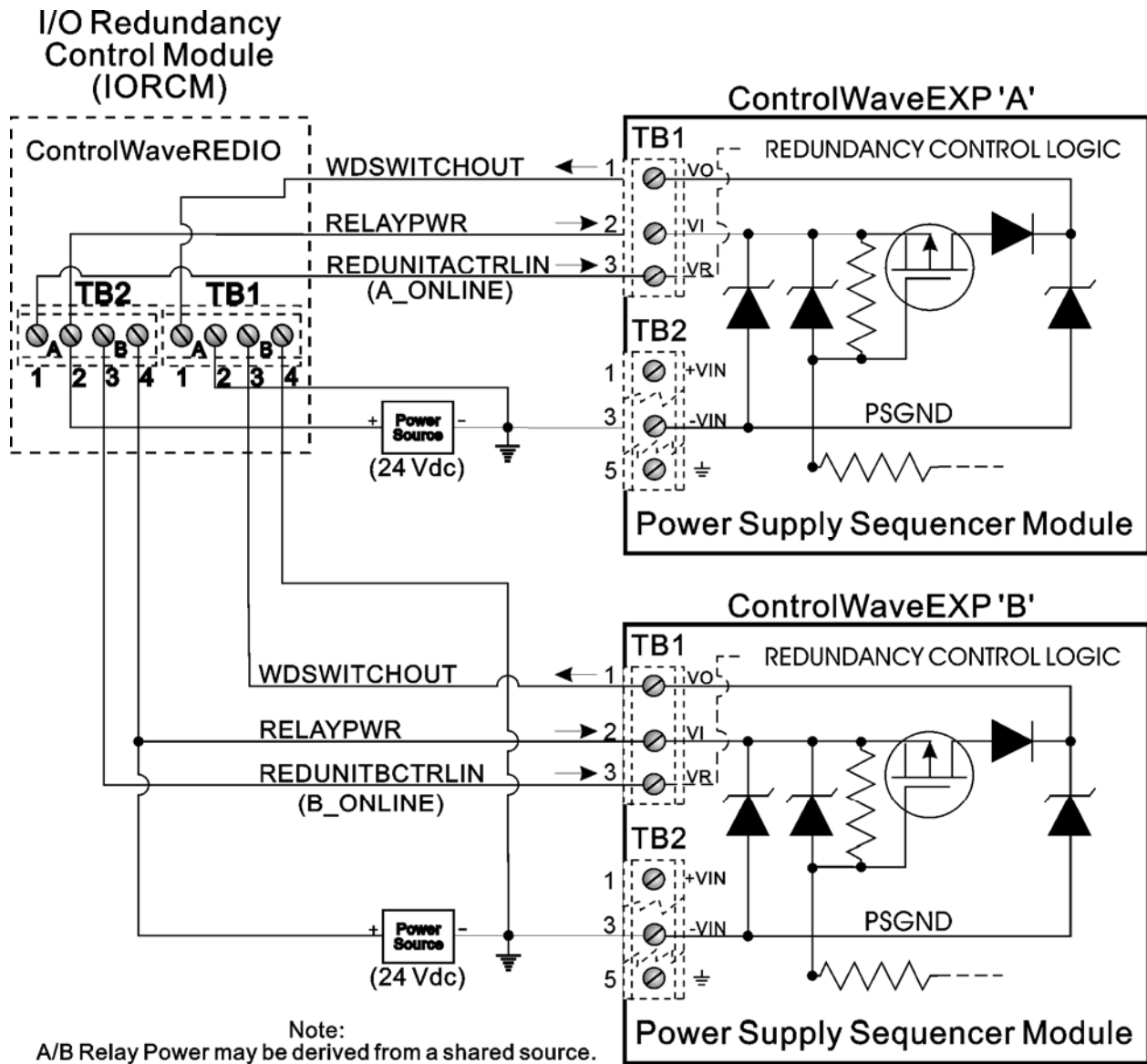

Figure 2-33 - ControlWaveREDIO to ControlWave or ControlWaveEXP Redundancy Control Field Wiring

I/O redundancy Control Module connectors TB1 and TB2 provide terminations for power, ground, Controller A & B Watchdog Bad input signals and Redundant Unit Control output signals as follows:

- TB1-1 = VO - Watchdog MOSFET Switch Input from Controller A (from PSSM TB1-1)
- TB1-2 = -VIN - Controller A Power Ground (PSSM TB2-2)
- TB1-3 = VO - Watchdog MOSFET Switch Input from Controller B (from PSSM TB1-1)
- TB1-4 = -VIN - Controller B Power Ground (PSSM TB2-2)
- TB2-1 = VR - Redundant Unit Control Output to Controller A (to PSSM TB1-3)
- TB2-2 = RLYPWR - +24Vdc Relay Power from external power source (to PSSM 'A' TB1-2)
- TB2-3 = VR - Redundant Unit Control Output to Controller B (to PSSM TB1-3)
- TB2-4 = RLYPWR - +24Vdc Relay Power from external power source (to PSSM 'B' TB1-2)
- TB3 1-2 = Normally Open Contact – If power system OK, relay is energized and TB3 1-2 is closed. If power system fails, relay is de-energized and TB3 1-2 is open.
- TB3 3-4 = Normally Closed Contact – If power system OK, relay is energized and TB3 3-4 is open. If power system fails, relay is de-energized and TB3 3-4 is closed.

2.3.4 PSMM Cover (see Figure 2-1)

The PSMM Cover is situated below the I/O Redundancy Control Module. It covers and protects the two PSMMs and can be removed to access the PSM Modules. Bundled wires and cables are routed downward between the PSM Modules and PSMM Cover. Three screws secure the PSMM Cover to the Chassis; two on top and one on the bottom.

2.4 OPERATIONAL DETAILS

ControlWave Redundant I/O and Communications Switch Units are utilized with two **ControlWave** Process Automation Controllers or with two **ControlWave** I/O Expansion Racks which in turn are shipped from the factory with firmware that allows them to be configured in conjunction with an IEC 61131 application program. This section provides information as follows:

- Operation of the IORCM's A/B Primary Select Switch (SW2)
- Operation of the IORCM's Key Operated A/B ENABLE Mode Switch (SW1)

Operational details on **ControlWave** Redundant I/O and Communications Switch Unit LEDs, are provided in Chapter 3 (see Section 3.3.2).

2.4.1 Operation of IORC Module Switches

Selection of the **PRIMARY** Controller, i.e., CW_A or CW_B is a function of the I/O Redundancy Control Module (IORCM). IORCM switch (SW1 & SW2) settings and Watchdog signals originating at CW_A and CW_B interact with IORCM control logic to select the redundant **ControlWave/ControlWaveEXP** unit that acts as the **PRIMARY** Controller.

2.4.1.1 SW1 - Key Operated A/B ENABLE Mode Switch

IORCM's key operated A/B Enable Mode Switch (SW1) has three positions and is used to determine whether the **PRIMARY** CPU selection is forced to CPU_A (A) or CPU_B (B) or is automatically selected (ENABLED). Forced **PRIMARY** selection is useful for diagnostic purposes, where a failed CPU Module may be placed on-line for debugging.

2.4.1.2 SW2 - A/B Primary Controller Select Switch

IORSM's A/B Primary Controller Select Switch (SW2) is a two position toggle switch that is used to select the **PRIMARY** Controller, i.e., Unit A's CPU (A) or Unit B's CPU (B) at power up **only** if the A/B Enabled Select Switch (SW1) has been set in the automatic selection (centered) position. The selected redundant unit (A or B) will be chosen as the **PRIMARY** System Controller if the IORSM's logic determines it is ready for on-line duty. Otherwise, the alternate CPU will be selected if it is OK.

2.4.1.3 Forcing a Fail-over to the BACKUP (Standby) Unit via Program Control

If desired, the user can trigger a redundant fail-over from On-line unit to the **BACKUP** unit based on conditions detected in the software.

To do this, users must incorporate the REDUN_SWITCH function into their project.

Excerpts from a POU using the REDUN_SWITCH function block in structured text (ST) are shown below. Comments appear in *italics*:

```
IF (SWITCHNOW) We are putting this at the top of the POU. If SWITCHNOW is TRUE a fail-over occurs right at the top. This ensures that fail-over doesn't occur in the middle of the POU, which would cause all changes within that execution cycle to be lost.
    THEN
        RDSTAT:=REDUN_SWITCH(SWITCHNOW);
        SWITCHNOW:=FALSE;
;
ENDIF;
:
: the main body of the POU would appear here. Somewhere in here, a test to determine whether a failure has occurred requiring a switchover must be made. The condition causing the failure can be anything the user chooses.
:
FAILURE: = some failure condition logic must be added here
:
:
IF (FAILURE) At the bottom of the POU, if the FAILURE condition, determined in the main body is TRUE, then SWITCHNOW is set TRUE, so at the top of the next execution cycle, the fail-over will occur.
    THEN
        SWITCHNOW:=TRUE;
    ELSE
        SWITCHNOW:=FALSE;
ENDIF
FAILURE:=FALSE;
```

In the structured text code, we use the REDUN_SWITCH function block, which takes the format:

```
statuscode:=REDUN_SWITCH(ibEnable)
```

Whenever the ibEnable variable is TRUE, a fail-over will be attempted immediately.

Some other things you should be aware of when using the REDUN_SWITCH function block:

- When using the REDUN_SWITCH function block, the condition that forces the fail-over, in this case, the FAILURE variable, should be a local, non-retain variable. The reason for this is that if the variable is retained, there is a possibility of repeated switchovers between A and B since the same failure condition value would be transferred from the **PRIMARY** (on-line) unit to the **BACKUP** (standby) unit, causing the new on-line unit to try to fail back, and so on.
- Fail-over only occurs if there is a valid **BACKUP** (standby) unit and the key operated A/B Enable Switch is in the **ENABLED** position.
- As soon as the REDUN_SWITCH function block executes with a TRUE ibEnable variable, the fail-over process begins *immediately*, no additional lines of code in the task are executed. For this reason, we recommend that the REDUN_SWITCH function block always be placed at the very beginning of the POU, to prevent a switchover in the middle of partial calculations, which would have to be discarded (see next item).

- Data updates to the **BACKUP** unit only occur at the end of a task's cycle, therefore, if a fail-over occurs somewhere during the task, no updates from that execution cycle will be sent to the standby unit. For this reason, although you can have multiple program POUs in your project, you may find it useful to confine all your program POUs to a single executing task, since if you use multiple tasks and a fail-over occurs, the tasks could become out of sync. This is because one or more tasks may not have completed an execution cycle when the fail-over occurs, thereby resulting in incomplete updates to the **BACKUP** unit; the updates for those tasks would be discarded.

2.4.1.4 Manually Forcing a Fail-over to the **BACKUP** (Standby) Unit

There are certain circumstances in which you might want to manually fail-over from the **PRIMARY** (on-line) CPU to the **BACKUP** (Standby) CPU. The most common situation would be if you need to perform some service or repair to the **PRIMARY** CPU, and therefore, you need to take it 'off-line' and have the **BACKUP** take over while the service or repair is being performed.

To force a manual fail-over, you can simply change the position of the A/B Enable key switch on the IORCM to select the unit which is currently the **BACKUP** unit; it will then become the new **PRIMARY** (on-line) unit.

Manually failing from "A" to "B"

If the "A" CPU is currently the **PRIMARY** CPU, and you want to manually fail-over to the **BACKUP** CPU "B", move the A/B Enable Mode key switch on the IORCM to the "B" position (right). The "B" CPU will now be the new **PRIMARY** unit.

Manually failing from "B" to "A"

If the "B" CPU is currently the **PRIMARY** CPU, and you want to manually fail-over to the **BACKUP** CPU "A", move the A/B Enable Mode key switch on the IORCM to the "A" position (left). The "A" CPU will now be the new **PRIMARY** unit.

Return the Key Operated A/B Enable Mode Switch to Automatic Mode

Once you have re-activated the controller which you were performing service on, we recommend that you set the A/B Enable Mode key switch to the automatic position ("ENABLED"). This will allow an automatic fail-over back to the previous **BACKUP** (standby) unit, if the current **PRIMARY** (on-line) unit should fail.

2.4.2 ControlWave Soft Switch Configuration and Communication Ports

Firmware defined soft switches that control many default settings for various system operating parameters such as BSAP Local Address, EBSAP Group Number, four (4) communication port parameters, etc., can be viewed and, if desired, changed via 'Configuration Web Pages' in Microsoft Internet Explorer via the Flash Configuration Utility. When connecting the **ControlWave/ControlWaveEXP** to the PC (local or network) for the first time you should be aware of the communication port default parameter settings provided below. *Note: Communication port factory defaults can be enabled anytime by setting CPU Board Switch SW1-3 to the OFF position.*

COM1: From the factory, COM1 defaults to 115.2 Kbaud (RS-232) using the Internet Point to Point Protocol (PPP). *Note: Port COM1 will be configured for RS-232 operation (at*

9600 baud) by setting CPU Switches SW1-3 and SW1-8 OFF. This will prevent the boot project from running and places the unit into diagnostic mode. To test COM1 using the WINDIAG program, it must not otherwise be in use and CPU Switch SW1-8 must be set to the OFF position. Connection between CWREDIO Comm. Port 1 and a PC requires the use of an RS-232 “Null Modem” cable (see Figure 2-4A).

- COM2: From the factory, COM2 on the CPU Board defaults to 9600 baud, 8-bits, no parity, 1 stop bit, BSAP/**ControlWave** Designer protocol operation. To test COM2 using the WINDIAG program, it must not otherwise be in use and CPU Switch SW1-8 must be set OFF to the OFF position. Connection between CWREDIO Comm. Port 2 and a PC requires the use of an RS-232 “Null Modem” cable (see Figure 2-4A).
- COM3: When factory set for RS-232 or RS-485 operation, COM3 on the SCB Board defaults to 9600 baud, 8-bits, no parity, 1 stop bit, BSAP/**ControlWave** Designer protocol operation. To test COM3 using the WINDIAG program, it must not otherwise be in use and CPU Switch SW1-8 must be set to the OFF position. An RS-232 “Null Modem” cable (see Figure 2-4A) can be connected between COM3 and the PC or an RS-485 cable (see Tables 2-1 & 2-2) can be connected between COM3 and the PC’s RS-485 Port.
- COM4: When factory set for RS-232 or RS-485 operation, COM4 on the SCB Board defaults to 9600 baud, 8-bits, no parity, 1 stop bit, BSAP/**Control-Wave** Designer protocol operation. To test COM4 using the WINDIAG program, it must not otherwise be in use and CPU Switch SW1-8 must be set to the OFF position. An RS-232 “Null Modem” cable (see Figure 2-4A) can be connected between COM4 and the PC or an RS-485 cable (see Tables 2-1 & 2-2) can be connected between COM4 and the PC’s RS-485 Port.

Comm. Port Hardware Notes:

1. All CWREDIO Comm. Ports are equipped with 9-pin Male D-Sub connectors.
2. COM1, COM2 and COM4 of Redundant **ControlWaves** or **ControlWaveEXPs** are equipped with 9-pin Male D-Sub connectors while COM3 is equipped with an 8-pin RJ-45 jack.
3. When connecting a PC to COM1 through COM4 of the CWREDIO or directly to COM1, COM2 or COM4 of a redundant **ControlWave** or redundant **ControlWaveEXP**: If the PC is equipped with an RS-232 Port that utilizes an RJ-45 jack, the use of the Bristol “Null Modem” cable P/N 392843-01-3 (see Figure 2-4A) and one Bristol “RJ45 to DB9 Adapter” cable P/N 392844-01-0 (see Figure 2-4D) will be required.
4. When connecting a PC’s RS-232 Port directly to COM3 of a redundant **ControlWave** or redundant **ControlWaveEXP**: If the PC is equipped with an RS-232 Port that utilizes an RJ-45 jack, use either a special “Null Modem” cable equipped with RJ-45 male plugs and wired like the null modem cable of Figure 4A, or use Bristol “Null Modem” cable P/N 392843-01-3 connected to two Bristol “RJ-45 to DB9 Adapter” cables P/N 392844-01-0 (see Figures 2-4A and 2-4D), to interconnect the PC directly to COM3 of a redundant CW or CWEXP.
5. When connecting a PC’s RS-232 Port directly to COM3 of a redundant **ControlWave** or redundant **ControlWaveEXP**: If the PC is equipped with an RS-232 Port that utilizes a standard 9-pin Male D-Sub connector, the use of the Bristol “Null Modem” cable P/N 392843-01-3 (see Figure 2-4A) and one BBI

“RJ-45 to DB9 Adapter” cable P/N 392844-01-0 (see Figure 2-4D) will be required. This RS-232 network, consisting of two cables, connects to COM3 of the **ControlWave/ControlWaveEXP** with an 8-pin RJ-45 male connector to the PC with a 9-pin D-type female connector.

6. If RS-485 communications is required an RS-485 cable can be assembled using the connections provided in Tables 2-1 (for 9-pin D-Sub connectors), 2-2 (RS-485 network connections) and 2-3 (for 8-pin RJ-45 connectors).

Section 3

SERVICE

3.1 SERVICE INTRODUCTION

This section provides general, diagnostic and test information for the **ControlWave Redundant I/O and Communications Switch Unit (CWREDIO)**.

The service procedures described herein will require the following equipment:

1. PC with null modem interface cable & WINDIAG Software
2. Loop-back plug, 9-pin female D-Sub (for RS-232) (see Figure 3-11)
1. Loop-back plug, 9-pin female D-Sub (for RS-485) (see Figure 3-12)
2. Ohmmeter or Continuity Tester (see Section 3.7.9)

The following test equipment can be used to test a Power Supply/Monitor Module:

1. DMM (Digital Multimeter): 5-1/2 digit resolution
2. Variable DC Supply: Variable to 30Vdc @ 2.5A (with vernier adjustment)

When **ControlWave Redundant I/O and Communications Switch Units** are serviced on site, it is recommended that any associated processes be closed down or placed under manual control. This precaution will prevent any processes from accidentally running out of control when tests are conducted.

Warning

*Harmful electrical potentials may still be present at the field wiring terminals even though the **ControlWave Redundant I/O and Communications Switch Unit's** power source(s) may be turned off or disconnected. Do not attempt to unplug termination connectors or perform any wiring operations until all the associated supply sources are turned off and/or disconnected.*

Warning

Always turn off the any external supply sources used for externally powered I/O circuits, before changing any modules.

3.2 COMPONENT REMOVAL/REPLACEMENT PROCEDURES

This section provides information on accessing CWREDIO modules for testing and installation/removal procedures. **Note CWREDIOs don't support module Hot Swapping; however, the I/O Modules resident in the redundant ControlWave's or redundant ControlWaveEXP's may be Hot Swapped.**

3.2.1 Accessing Modules for Testing

Testing and replacement of CWREDIO modules should only be performed by technically qualified persons. Familiarity with the disassembly and test procedures described in this manual are required before starting. Any damage to the CWREDIO resulting from improper handling or incorrect service procedures will not be covered under the product

warranty agreement. If these procedures cannot be performed properly, the unit should be returned to Bristol Babcock (with prior authorization from Bristol Babcock) for factory evaluation and repairs. All **ControlWave** Redundant I/O and Communications Switch Unit Modules are factory sealed to prevent tampering; if the seal is broken by other than Bristol Babcock personnel, the warranty is void.

3.2.2 Removal/Replacement of the I/O Redundancy Control Module

The I/O Redundancy Control Module (IORCM) is secured to the Chassis by three Captured Panel Fasteners.

1. Prior to removal of the IORCM, it is recommended that any associated processes be closed down or placed under manual control. Turn both PSMs OFF.
1. Before disconnecting any cables from the IORCM make sure they are identified (so they can be re-installed into their assigned location). Disconnect the communication cables associated with CW_A/CWEXP_A and CW_B/CWEXP_B from IORCM Connectors J5 and J6 respectively. Disconnect the communication cables from J1 through J4 as required. Unplug removable connectors TB1, TB2, and TB3.
3. Turn the IORCM's three Captured Panel Fasteners counterclockwise until the unit can be removed from the Chassis. Gently remove the IORCM from the Chassis.
4. To replace the IORCM, align the Logic & Relay Board's Backplane Interface Connector with Backplane Connector P3 and carefully insert the unit until its three Captured Panel Fasteners (two near the top and one near the bottom) can be turned to secure the unit. Turn the three Captured Panel Fasteners clockwise until the IORCM is fully seated.
5. Re-install the connectors removed in step 2.
6. Reapply power to both PSMMs.

3.2.3 Removal/Replacement of a Power Supply/Monitor Module

1. Turn the PSM Cover's three Quarter Turn Fasteners (two on top, one on the bottom) counterclockwise until it can be removed from the Chassis and then remove it.
2. If the CWREDIO is running, and the PSSMs share a bulk power source, perform step 3. If the CWREDIO is running and separate bulk power supplies are utilized shut off power to the bulk supply associated with the failed PSSM and then perform step 3.
3. Unplug removable connector TB1 from the PSMM in question.
5. Turn the two Captured Panel Fasteners (associated with the PSMM in question) counterclockwise until it can be removed from the Chassis and then remove it.
3. To replace a PSMM, align the unit with its assigned slot and Backplane connector (J1 or J2) and carefully insert it until fully seated. Turn the PSMM's Captured Panel Fasteners Clockwise until they are snug. Re-install power connector TB1, and if required, turn on power at the bulk power source. Turn the PSSM's Power Switch to the ON 'I' position and replace the PSM Cover securing it to the chassis via its three Quarter Turn Fasteners.

3.2.4 Removal/Replacement of a I/O Redundancy Switch Module

1. Shut down or place under manual control all processes associated with the I/O Redundancy Switch Module (IORSM) being removed.
2. Remove the CW_A/CWEXP_A and CW_B/CWEXP_B I/O Interface cables from their respective IORSM connectors making sure that they are identified (so they can be re-installed into their assigned connectors).
3. Remove the Terminal Housing Assembly (see Figures 2-8 and 2-9).

4. Turn the Terminal/Header Block's Quarter Turn Fasteners (counterclockwise) and remove the Terminal/Header Block Assembly (with wiring harness) from the IORSM.
5. Turn the IORSM's Captured Panel Fasteners (counterclockwise) until it can be removed from the Chassis. Remove the IORSM assembly in question from the Chassis. **Note: To ease IORSM removal, reinstall the Terminal Housing Assembly and (with Terminal Door open) grasp the Terminal Handle and remove the IORSM.**
4. If not already done, remove the Terminal/Header Block Assembly from the replacement IORSM.
5. Install the replacement IORSM into the same I/O slot that the assembly in question was removed from. When the assembly is fully seated, turn the Module's Captured Panel Fasteners (clockwise) to secure the unit to the Chassis.
6. Install the original Terminal/Header Block Assembly (with wiring harness) onto the replacement IORSM (turning the Quarter Turn Fasteners (clockwise).
7. Replace the Terminal Housing Assembly.
8. Remove from manual control any processes associated with the IORSM.

3.3 TROUBLESHOOTING TIPS

3.3.1 Power Supply/Monitor Module (PSMM) Voltage Checks

One or two bulk power sources can be connected to the PSMM. PSMM connector TB1 provides 3 input terminal connections for bulk power (see Figure 3-1):

TB1-1 = (+VIN) (+20.7V to +30V dc for +24V supply)

TB1-2 = (-VIN) (Supply Ground)

TB1-3 = Chassis Ground - CHASSIS (\neq)

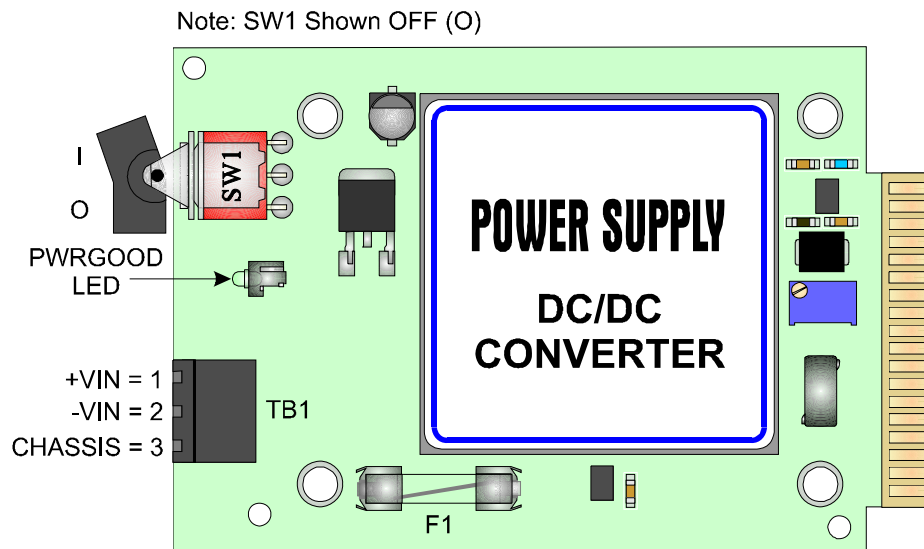

Figure 3-1 - Power Supply/Monitor Board Component Designations

Bulk supply voltages can be checked at TB1 using a voltmeter or multimeter. PSMM's are factory configured for use with a nominal 24Vdc bulk power supply. The maximum and minimum input power switch points can be tested with the use of a Variable dc Power Supply connected between TB1-1 (+) and TB1-2 (-). By increasing the input voltage (starting at +20.7Vdc), you can determine the point at which the unit will turn on, i.e., the point at which the green PWRGOOD LED on the PSMM comes ON (Vt+). By decreasing the input voltage (starting at +30Vdc), you can determine the point at which the unit turns off, i.e., the point at which the green PWRGOOD LED on the PSMM goes OFF (Vt-). If the

value of the bulk power supply's +24Vdc output approaches the value of Vt+ or Vt- it should be replaced by one with the correct +24V output.

3.3.2 LED Checks

LEDs provide operational and diagnostic functions. A brief synopsis of the individual **ControlWave** Redundant I/O and Communications Switch Unit LEDs is provided as follows:

PSMM: 1 LED: PWRGOOD

IORCM: 6 LEDs: A Power System Status, B Power System Status, A Unit On-Line, A Unit Fail, B Unit On-Line and B Unit Fail

Note: These status indicators are powered from an additional independent +3.3Vdc power source on the IORSM's Logic Board (+3.3V5), and display the status of the external CW/CWEXP units under CWIORCM control and the condition of the power sources used or generated on the CWIORCM.

IORSM: 2 LEDs: A On-Line Status and B On-Line Status

ControlWave Redundant I/O and Communications Switch Unit (CWREDIO) LED designations and functions are provided in Table 3-1.

Table 3-1 - CWREDIO LED Assignment

Module	LED Name	LED Color	Function
PSMM1	PWRGOOD	Green	ON = Power Supply 1 Normal operation - O.K.
PSMM2	PWRGOOD	Green	ON = Power Supply 2 Normal operation - O.K.
IORCM	CR1 - Unit A On-Line	Green	GREEN = CW_A is On-line as Primary Controller
IORCM	CR2 - Unit B On-Line	Green	GREEN = CW_B is On-line as Primary Controller
IORCM	CR3 - Unit A Fail	Red	RED = CW_A Watchdogged (failed)
IORCM	CR4 - Unit B Fail	Red	RED = CW_B Watchdogged (failed)
IORCM	CR5 - B Power System Status	Red Green	GREEN = +3.3V4, VCC_RED, RED_RLY PWR OK RED = At least one of the above supplies has failed
IORCM	CR6 - A Power System Status	Red Green	GREEN = +3.3V1, +3.3V2, +3.3V3 are OK RED = At least one of the above supplies has failed
IORSM	A On-Line Status	Green	ON = System A I/O Module Selected
IORSM	B On-Line Status	Green	ON = System B I/O Module Selected

All **ControlWave/ControlWaveEXP** Modules contain light emitting diodes (LEDs) that provide operational and diagnostic functions. **ControlWave** and **ControlWaveEXP** LEDs are discussed in instruction manuals CI-ControlWave and CI-ControlWaveEXP, respectively. A brief synopsis of the individual module LEDs is provided as follows:

PSSM: 3 LEDs: 1 MC LED, 1 PWRFAIL LED & 1 PWRGOOD LED

CPUB: 2 LEDs per Comm. Port = 4, 2 LEDs per Ethernet Port = 2
1 Idle LED, 1 Watchdog LED & the Port 80 Display Assembly

SCB: 2 LEDs per Comm. Port = 4, 2 LEDs/Ethernet = 4

AIM: 33 LEDs: 1 Status LED plus 2 LEDs per point x 16 = 32 AI LEDs

AOM: 2 LEDs: 1 FAIL LED & 1 GOOD LED

DIM: 33 LEDs: 1 Status LED plus 1 LED per point x 32 = 32 DI LEDs

DOM: 33 LEDs: 1 Status LED plus 1 LED per point x 32 = 32 DO LEDs

UDIM: 14 LEDs: 1 FAIL LED, 1 PASS LED plus 1 LED per point x 12 = 12 UI LEDs

ControlWave/ControlWaveEXP Module LED designations and functions are provided in Table 3-2.

Table 3-2 - CW_A/CWEXP_A & CW_B/CWEXP_B LED Assignment

Module	LED Name	LED Color	Function * and Figures Referenced to CI-ControlWave
PSSM	MC	Red	ON 2msec after PWR_FAIL goes low *
PSSM	PWRFAIL	Red	ON = Bulk or Regulated Power out of Specs. *
PSMM	PWRGOOD	Green	ON = Normal operation - all supplies O.K. *
CPUB	CR1 - WATCHDOG	Red	ON = Watchdog Condition - OFF = Normal
CPUB	CR2 - IDLE	Red	ON = Idle
CPUB	CR3 - COMM 1 RX	Red	ON = RX Activity (Top-Left - see Fig 3-2)
CPUB	CR3 - COMM 1 TX	Red	ON = TX Activity (Top-Right -see Fig 3-2)
CPUB	CR3 - COMM 2 RX	Red	ON = RX Activity (Bottom-Left - see Fig 3-2)
CPUB	CR3 - COMM 2 TX	Red	ON = TX Activity (Bottom-Right -see Fig 3-2)
CPUB	CR8 - ENET Port 1	Red/Green	ON Red = Data Collision (Left - see Fig 3-2)
CPUB	CR8 - ENET Port 1	Red/Green	ON Green = Receiving Data (Left -see Fig 3-2)
CPUB	CR8 - ENET Port 1	Red/Green	ON Red = Transmitting Data (Right - see Fig 3-2)
CPUB	CR8 - ENET Port 1	Red/Green	ON Green = Link O.K. (Right -see Fig 3-2)
SCB	CR2 - COMM 3 RX	Red	ON = RX Activity (Top-Left - see Fig 3-2)
SCB	CR2 - COMM 3 TX	Red	ON = TX Activity (Top-Right -see Fig 3-2)
SCB	CR2 - COMM 4 RX	Red	ON = RX Activity (Bottom-Left - see Fig 3-2)
SCB	CR2 - COMM 4 TX	Red	ON = TX Activity (Bottom-Right -see Fig 3-2)
SCB	CR4 - ENET Port 2	Red/Green	ON Red = Data Collision (Left - see Fig 3-2)
SCB	CR4 - ENET Port 2	Red/Green	ON Green = Receiving Data (Left -see Fig 3-2)
SCB	CR4 - ENET Port 2	Red/Green	ON Red = Transmitting Data (Right - see Fig 3-2)
SCB	CR4 - ENET Port 2	Red/Green	ON Green = Link O.K. (Right -see Fig 3-2)
SCB	CR5 - ENET Port 3	Red/Green	ON Red = Data Collision (Left - see Fig 3-2)
SCB	CR5 - ENET Port 3	Red/Green	ON Green = Receiving Data (Left -see Fig 3-2)
SCB	CR5 - ENET Port 3	Red/Green	ON Red = Transmitting Data (Right - see Fig 3-2)
SCB	CR5 - ENET Port 3	Red/Green	ON Green = Link O.K. (Right) (see Fig 3-2)
CPUB	PORT 80 DISPLAY	Red LED	LED Matrix Status Codes (see Fig 3-2) **
AIM	AI Bd. Status	Red/Green	ON Red = Fail State/Bd. not recognized ON Green = Normal State (see Fig 3-3)
AIM	RANGE (16 LEDs) (1 Per Point)	Red	LED ON = Overrange or Underrange condition (see Fig 3-3)
AIM	RANGE (16 LEDs) (1 Per Point)	Green	LED ON = In-range condition (see Fig 3-3)
AOM	AO Bd. Status Fail	Red ***	LED ON = AI Bd. Fail State/Bd. not recognized
AOM	AO Bd. Status Pass	Green ***	LED ON = AI Bd. Normal or O.K. State
DIM	DI Bd. Status	Red/Green	ON Red = DI Bd. Fail State/BD. not recognized ON Green = DI Bd. Normal State (see Fig. 3-5)
DIM	INPUT (32 LEDs) (1 Per Point)	Red	LED ON = Input is present LED OFF = Input is not present (see Fig 3-5)
DOM	DO Bd. Status	Red/Green	ON Red = Fail State/Module not recognized ON Green = Normal State (see Fig 3-6)
DOM	OUTPUT (32 LEDs) (1 Per Point)	Red	LED ON = Output is ON (see Fig 3-6)
UIM	UI Bd. Status Fail	Red ****	LED ON = UI Bd. Fail State/Bd. not recognized
UIM	UI Bd. Status Pass	Green ****	LED ON = UI Bd. Normal or O.K. State
UIM	INPUT (12 LEDs) (1 Per Point)	Red	LED ON = Input activity on input is present LED OFF = No activity on input (see Fig 3-7)

* = see Figure 3-1, ** = see Sections 2.4.2 & 3.4.4, *** = see Figure 3-4, **** = see Figure 3-7

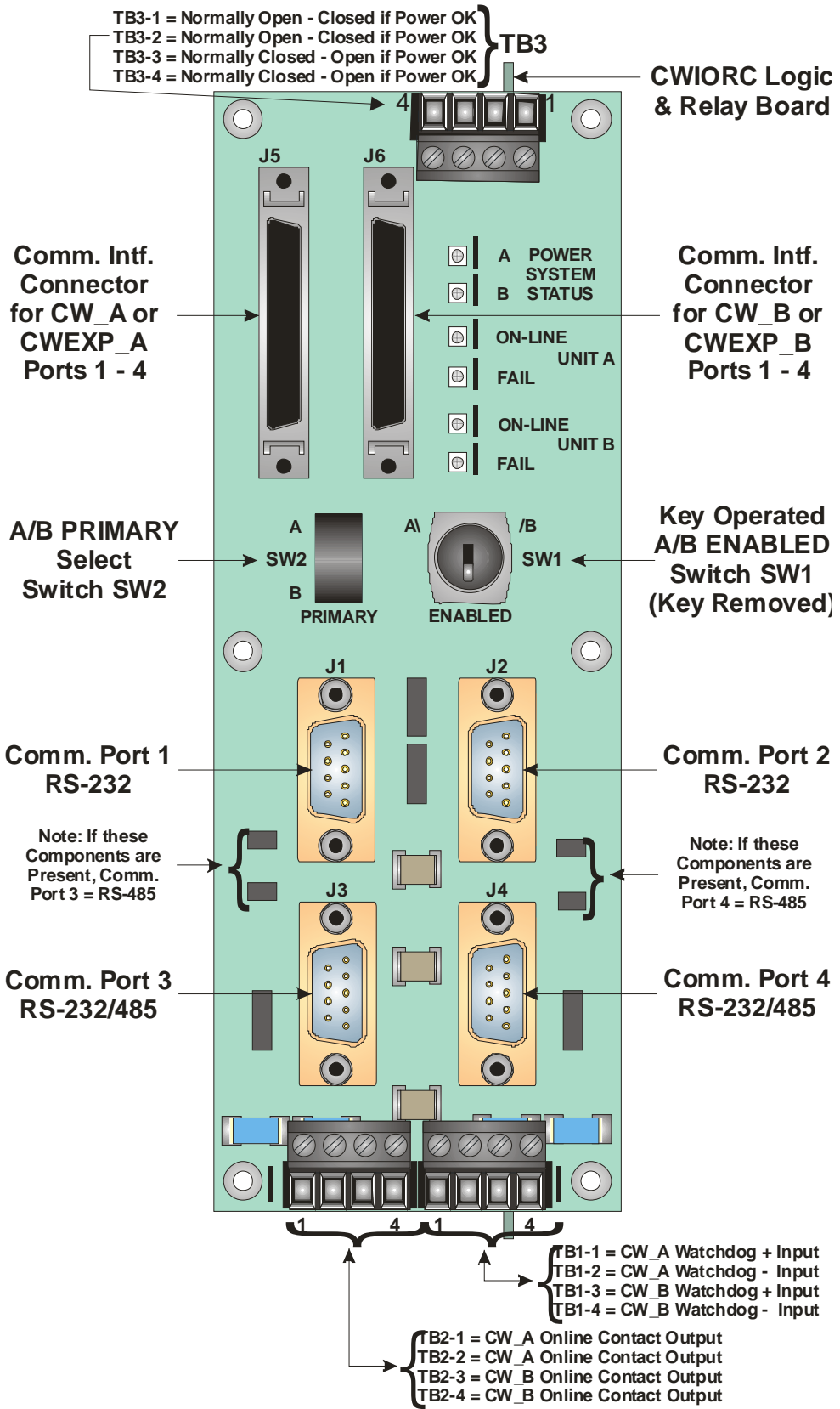
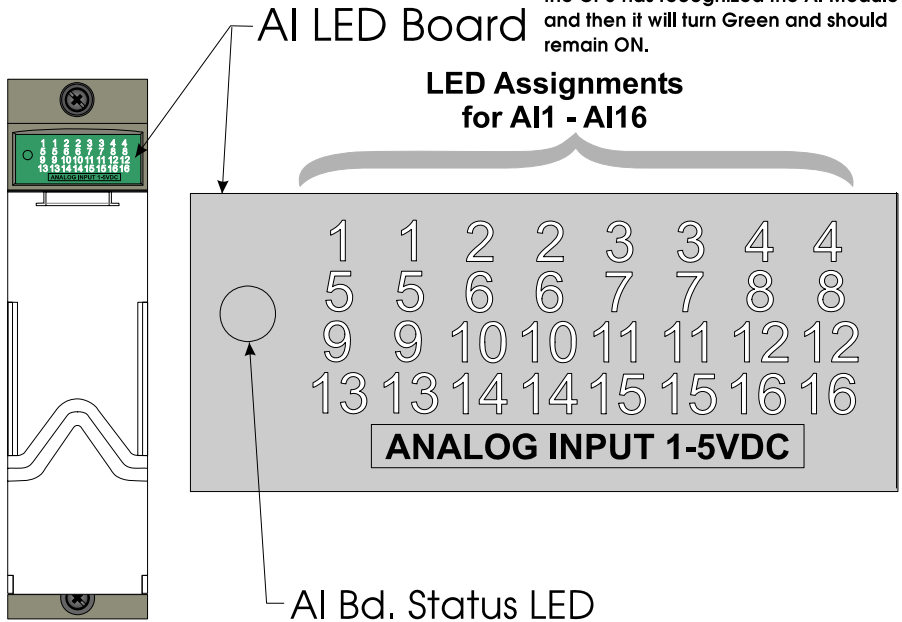

Figure 3-2 - I/O Redundancy Control Module - Connector, Port, Switch & LED Designations

Red AI Bd. Status LED = AI Bd. not recognized or failed.
 Green AI Bd. Status LED = AI Bd. recognized and normal.
 Red AIXX = Overrange/Underrange condition.
 Green AIXX = In-range condition.

Note: The Status LED will turn ON (Red) whenever power is initially applied to the AI Module. It will remain Red until the CPU has recognized the AI Module and then it will turn Green and should remain ON.



Note: Open Inputs default to an underrange condition

Figure 3-3 - Analog Input (AI) Module LED Designations

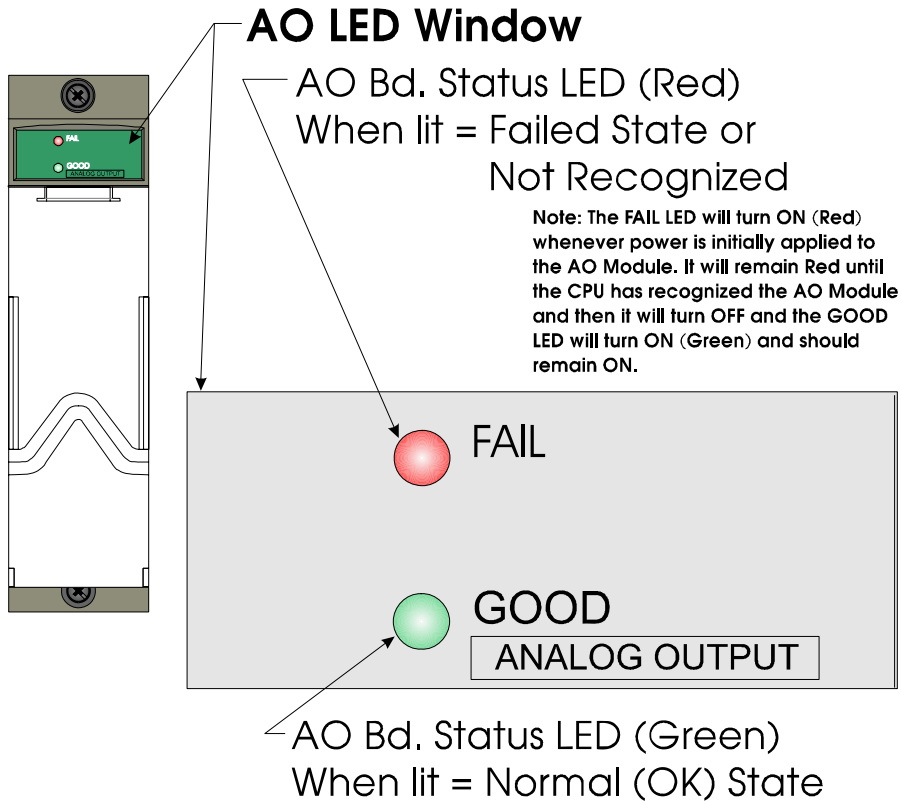

Figure 3-4 - Analog Output (AO) Module LED Designations

Red DI Bd. Status LED = DI Bd. not recognized or failed.
 Green DI Bd. Status LED = DI Bd. recognized and normal.
 Red DIXX = Input is present.
 OFF DIXX = Input is not present.

Note: The Status LED will turn ON (Red) whenever power is initially applied to the DI Module. It will remain Red until the CPU has recognized the DI Module and then it will turn Green and should remain ON.

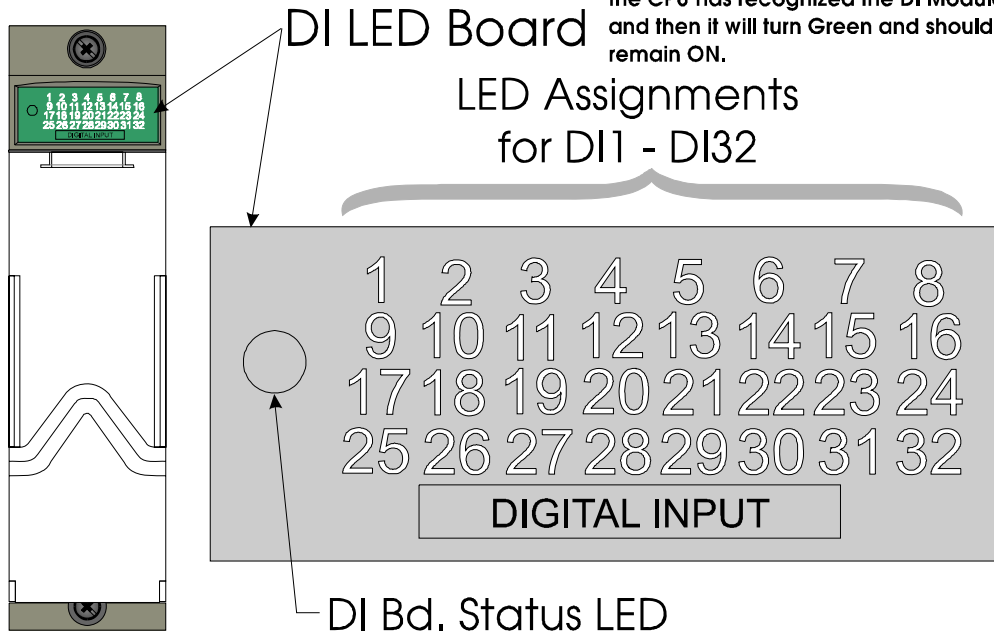

Figure 3-5 - Digital Input (DI) Module LED Designations

Red DO Bd. status LED = DO Bd. not recognized or failed.
 Green DO Bd. status LED = DO Bd. recognized and normal.
 Red DOXX = Output is ON.

Note: The Status LED will turn ON (Red) whenever power is initially applied to the DO Module. It will remain Red until the CPU has recognized the DO Module and then it will turn Green and should remain ON.

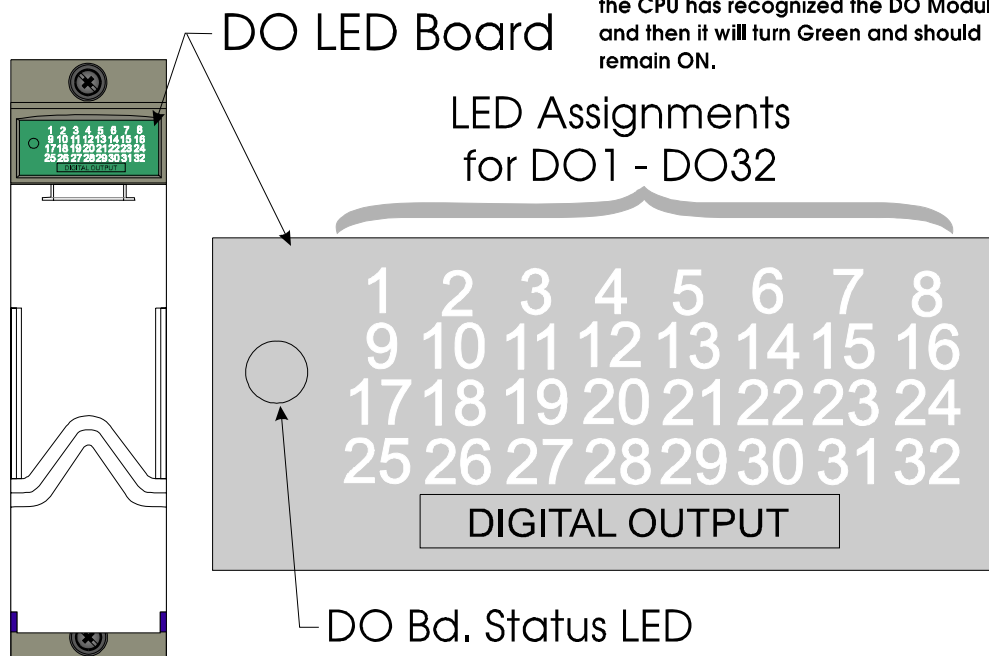

Figure 3-6 - Digital Output (DO) Module LED Designations

UDI Bd. Status LED (Red) = UDI Bd. not recognized or failed.
 UDI Bd. Status LED (Green) = UDI Bd. recognized and normal.
 ON UDIXX = Input is present.
 OFF UDIXX = Input is not present.

Note: The Status LED will turn ON (Red) whenever power is initially applied to the UDI Module. It will remain Red until the CPU has recognized the UDI Module and then it will turn Green and should remain ON.

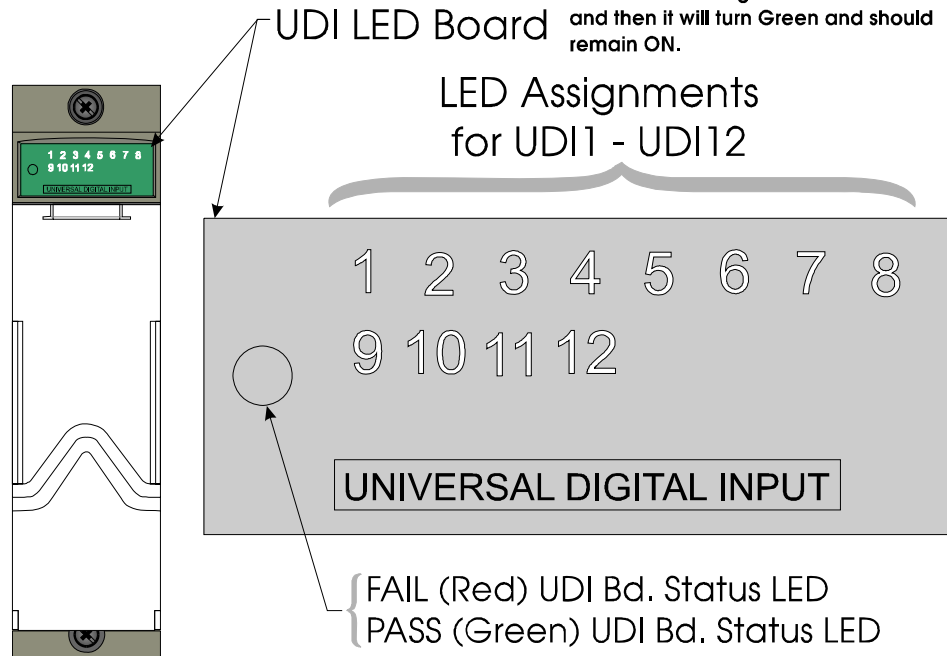

Figure 3-7 - Universal Digital Input (UDI) Module LED Designations

3.3.3 Wiring/Signal Checks

Check I/O Field Wires at the Card Edge Terminal Blocks and at the field device. Check wiring for continuity, shorts & opens. Check I/O signals at their respective Terminal Blocks (see Table 3-3).

Table 3-3 - I/O Field Wiring - Terminal Block Reference List

I/O Subsystem	Figures	Notes
Discrete Inputs	2-10 through 2-14	See Section 2.3.2.4
Discrete Outputs	2-15 through 2-18	See Section 2.3.2.5
Analog Inputs	2-19 through 2-24	See Section 2.3.2.6
Analog Output	2-25 through 2-28	See Section 2.3.2.7
Universal Inputs	2-29 through 2-32	See Section 2.3.2.8
Watchdog Ckt.	2-35	See Section 2.3.2.3

3.4 GENERAL SERVICE NOTES

Certain questions or situations frequently arise when servicing the controllers. Some items of interest are provided in Sections 3.4.1 through 3.4.4.

3.4.1 Extent of Field Repairs

Field repairs to **ControlWave Redundant I/O and Communications Switch Units (CWREDIO)** are strictly limited to the replacement of complete modules. CWREDIO Modules are sealed and employ a tamper indicator. Disassembly of a CWREDIO Module

constitutes tampering and will violate the warranty. Defective CWREDIO Chassis or Modules must be returned to an authorized service center.

3.5 WINDIAG DIAGNOSTICS

WINDIAG Software is a diagnostic tool used for testing **ControlWave/ControlWaveEXP** I/O Modules, CPU memory, communications ports, etc., for proper performance. The **ControlWave/ControlWaveEXP** must be communicating with a PC equipped with WINDIAG. **ControlWave/ControlWaveEXP** CPU Module configuration switch SW1-8 must be set to the OFF (Closed) position to enable diagnostics. Communication between the **ControlWave/ControlWaveEXP** (with/without application loaded) and the PC can be made via a Local or Network Port with the following restrictions:

- **ControlWave/ControlWaveEXP** CPU Board Switch SW1-8 must be OFF (closed) to run the WINDIAG program. Setting SW1-8 OFF will prevent the 'Boot Project' from running and will place the unit into diagnostic mode.
- Any **ControlWave/ControlWaveEXP** communication port can be connected to the PC provided their port speeds match. Many PCs have a COM1 port (typically RS-232 and defaulted to 9600 bps operation).
- The **ControlWave/ControlWaveEXP** communication port to be tested using the WINDIAG program must be configured for 9600 baud, 8-bits, no parity, 1 stop bit, BSAP/**ControlWave** Designer protocol operation. This can be accomplished via user defined Soft Switches, or for ports COM2, COM3 and COM4, by setting **ControlWave/ControlWaveEXP** CPU Board Switch SW1-3 OFF (closed).
- Communication port COM1 is only forced to 9600 bps operation when **ControlWave/ControlWaveEXP** CPU Switches SW1-3 and SW1-8 have both been set OFF (closed). COM1 can also be set to 9600 bps operation via user defined Soft Switches.
- Setting **ControlWave/ControlWaveEXP** CPU Board Switches SW1-3 and SW1-8 OFF (closed) prevents the 'Boot Project' from running, places the unit into diagnostic mode and forces communication ports COM1 through COM4 to operate at 9600 baud.

COM1: From the factory, COM1 defaults to 115.2 kbd (RS-232) using the Internet Point to Point Protocol (PPP). *Note: Port COM1 will be configured for RS-232 operation (at 9600 baud) by setting CPU Switches SW1-3 and SW1-8 OFF. This will prevent the boot project from running and places the unit into diagnostic mode.* To test COM1 using the WINDIAG program, it must not otherwise be in use and CPU Switch SW1-8 must be set to the OFF position. Connection between CWREDIO Comm. Port 1 and a PC requires the use of an RS-232 "Null Modem" cable (see Figure 2-4A).

COM2: From the factory, COM2 on the CPU Board defaults to 9600 baud, 8-bits, no parity, 1 stop bit, BSAP/**ControlWave** Designer protocol operation. To test COM2 using the WINDIAG program, it must not otherwise be in use and CPU Switch SW1-8 must be set to the OFF position. Connection between CWREDIO Comm. Port 2 and a PC requires the use of an RS-232 "Null Modem" cable (see Figure 2-4A).

COM3: When factory set for RS-232 or RS-485 operation, COM3 on the SCB Board defaults to 9600 baud, 8-bits, no parity, 1 stop bit, BSAP/**ControlWave** Designer protocol operation. To test COM3 using the WINDIAG program, it must not

otherwise be in use and CPU Switch SW1-8 must be set to the OFF position. An RS-232 “Null Modem” cable (see Figure 2-4A) can be connected between COM3 and the PC or an RS-485 cable (see Tables 2-1 & 2-2) can be connected between COM3 and the PC’s RS-485 Port.

COM4: When factory set for RS-232 or RS-485 operation, COM4 on the SCB Board defaults to 9600 baud, 8-bits, no parity, 1 stop bit, BSAP/**ControlWave** Designer protocol operation. To test COM4 using the WINDIAG program, it must not otherwise be in use and CPU Switch SW1-8 must be set to the OFF position. An RS-232 “Null Modem” cable (see Figure 2-4A) can be connected between COM4 and the PC or an RS-485 cable (see Tables 2-1 & 2-2) can be connected between COM4 and the PC’s RS-485 Port.

Comm. Port Hardware Notes:

1. All CWREDIO Comm. Ports are equipped with 9-pin Male D-Sub connectors.
2. COM1, COM2 and COM4 of Redundant **ControlWaves** or **ControlWaveEXPs** are equipped with 9-pin Male D-Sub connectors while COM3 is equipped with an 8-pin RJ-45 jack.
1. When connecting a PC to COM1 through COM4 of the CWREDIO or directly to COM1, COM2 or COM4 of a redundant **ControlWave** or redundant **ControlWaveEXP**: If the PC is equipped with an RS-232 Port that utilizes an RJ-45 jack, the use of the “Null Modem” cable P/N 392843-01-3 (see Figure 2-4A) and one “RJ45 to DB9 Adapter” cable P/N 392844-01-0 (see Figure 2-4D) will be required.
2. When connecting a PC’s RS-232 Port directly to COM3 of a redundant **ControlWave** or redundant **ControlWaveEXP**: If the PC is equipped with an RS-232 Port that utilizes an RJ-45 jack, use either a special “Null Modem” cable equipped with RJ-45 male plugs and wired like the null modem cable of Figure 4A, or use “Null Modem” cable P/N 392843-01-3 connected to two “RJ-45 to DB9 Adapter” cables P/N 392844-01-0 (see Figures 2-4A and 2-4D), to interconnect the PC directly to COM3 of a redundant CW or CWEXP.
3. When connecting a PC’s RS-232 Port directly to COM3 of a redundant **ControlWave** or redundant **ControlWaveEXP**: If the PC is equipped with an RS-232 Port that utilizes a standard 9-pin Male D-Sub connector, the use of the “Null Modem” cable P/N 392843-01-3 (see Figure 2-4A) and one “RJ-45 to DB9 Adapter” cable P/N 392844-01-0 (see Figure 2-4D) will be required. This RS-232 network, consisting of two cables, connects to COM3 of the **ControlWave/ControlWaveEXP** with an 8-pin RJ-45 male connector to the PC with a 9-pin D-type female connector.
6. If RS-485 communications is required an RS-485 cable can be assembled using the connections provided in Tables 2-1 (for 9-pin D-Sub connectors), 2-2 (RS-485 network connections) and 2-3 (for 8-pin RJ-45 connectors).
- 7.

Others: Any of the three optional Ethernet Ports can be connected directly or via a network to a PC equipped with an Ethernet Port (see CI-**ControlWave** - Figures 2-7, 2-12, 2-13 and 2-14 or CI-**ControlWaveEXP** - Figures 2-7, 2-10, 2-11 and 2-12). If not configured with an address, the **ControlWave/ControlWaveEXP** uses DHCP (by default) to obtain an IP address.

To use the WINDIAG program place any critical process (associated with the **ControlWave/ControlWaveEXP** unit in question) under manual control. WINDIAG cannot be run while the **ControlWave/ControlWaveEXP** application is running. Set the **ControlWave/**

ControlWaveEXP CPU Modules Switches SW1-3 and SW1-8 to the OFF (closed) position. Perform steps 1 through 6 below.

1. Start the OpenBSI NetView Program. A menu similar to Figure 3-8 will appear.

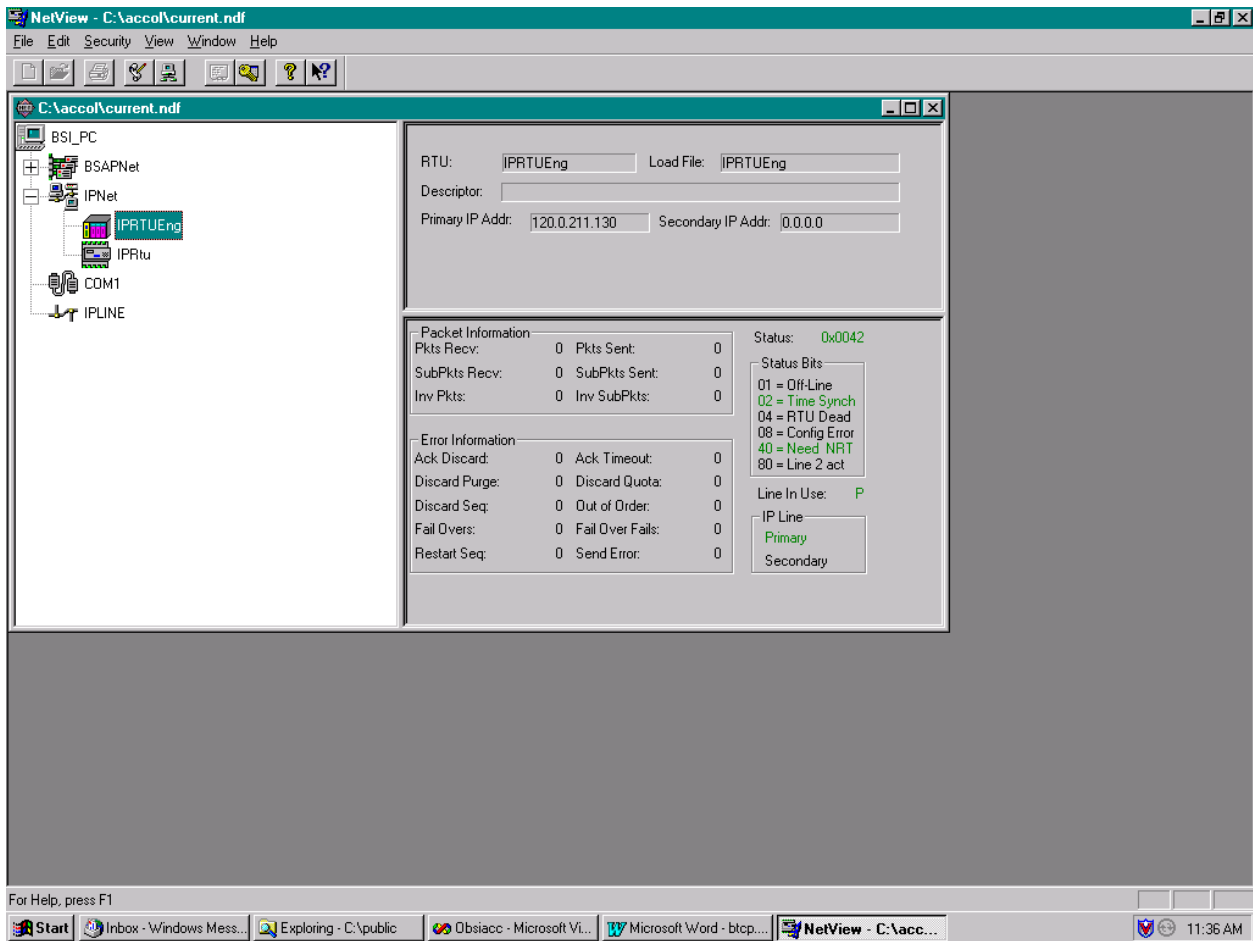

Figure 3-8 - Netview Startup Menu - Example with Multiple Networks

2. To start the WINDIAG program, go to the Start Program's menu, select OpenBSI Tools, then select Utilities Programs and then select Diagnostics.
3. Once WINDIAG has been entered, the Main Diagnostics Menu of Figure 3-9 will appear.
4. Select the module to be tested. Enter any prompted parameters (slot #, etc.). WINDIAG will perform the diagnostics and display pass/fail results.
5. After all diagnostic testing has been performed, exit the WINDIAG program and then exit the Netview Program if there aren't any other **ControlWave/ControlWaveEXP** units to be tested.

When you close the Netview program you will be prompted as to whether or not you want to close the OpenBSI program; select Yes.

6. Set the **ControlWave/ControlWaveEXP** CPU Switch SW1-8 to the ON (Open) position. The **ControlWave/ControlWaveEXP** should resume normal operation.

3.5.1 Diagnostics Using WINDIAG

All **ControlWave/ControlWaveEXP** Modules except the Power Supply/Sequencer Module can be tested using the WINDIAG program. **ControlWave** Redundant I/O and Communication Switch Unit Modules are indirectly supported by the WINDIAG program. **ControlWave** I/O Redundancy Switch Modules can be tested indirectly via WINDIAG, i.e., by running WINDIAG in conjunction with the associated **ControlWave/ControlWaveEXP** I/O Module, all individual I/O points can be checked. The communication Ports on the **ControlWave** I/O Redundancy Control Module can be checked along with the associated **ControlWave/ControlWaveEXP** communication ports via WINDIAG's Communication Diagnostics. From WINDIAG's Main Diagnostics Menu (see Figure 3-9) the following diagnostic tests can be performed:

CPU & Peripherals Diagnostic:	Checks the CPU Module (except for RAM & PROM).
PROM/RAM Diagnostic:	Checks the CPU's RAM and PROM hardware.
Communications Diagnostic:	Checks Comm. Ports 1 through 4 - The External loop-back tests require the use of a loop-back plug.
Ethernet Diagnostic:	Checks Ethernet Ports 1 through 3 - The Loop-back Out Twisted Pair tests require the use of a loop-back plug.
Analog Output Diagnostic:	Checks the Analog Output Module.
Analog Input Diagnostic:	Checks the Analog Input Module.
Discrete I/O Diagnostic:	Checks the DI Module and/or the DO Module.
High Speed Counter Diagnostic:	Checks the Universal Digital Input Module

3.5.1.1 Communications Diagnostic Port Loop-back Test

WINDIAG's Communications Diagnostic Menu (see Figure 3-11) provides for selection of the communication port to be tested (1 through 4). Depending on the type of network (RS-232 or RS-485) and the port in question, a special loop-back plug is required as follows:

If testing the Communications Port in question at the **CWREDIO** unit use a 9-pin female D-Type loop-back plug (see Fig. 3-10).

If testing the Comm. Port in question at the **ControlWave** or **ControlWaveEXP** unit, select an appropriate loopback plug as follows:

Ports 1, 2 & 4 set-up for RS-232 use a 9-pin female D-type loop-back plug (see Fig. 3-10).

Port 4 set-up for RS-485 use a 9-pin female D-type loop-back plug (see Fig. 3-12).

Port 3 set-up for RS-232 use an 8-pin male RJ-45 loop-back plug (see Fig. 3-10).

Port 3 set-up for RS-485 use an 8-pin male RJ-45 loop-back plug (see Fig. 3-12).

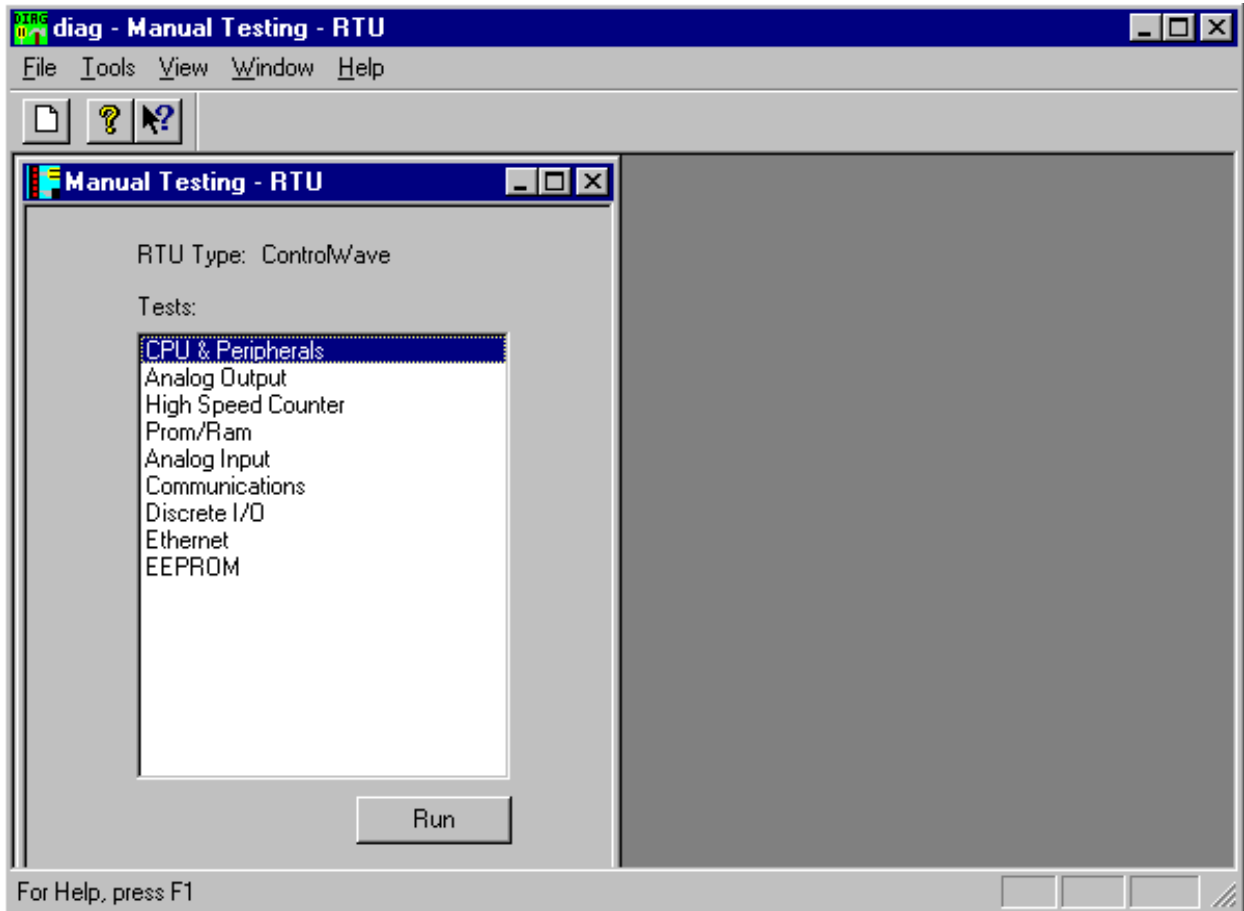

Figure 3-9 - WINDIAG Main Diagnostics Menu

This group of tests verifies the correct operation of the Communication Interface. COM1, COM2, COM3 and COM4 can be tested with this diagnostic. The **ControlWave/ControlWaveEXP** communication port that is connected to the PC (directly or via the CWREDIO) (local or network and used for running these tests) can't be tested until diagnostics has been established via one of the other ports, i.e., to test all communication ports (via WINDIAG), communications with the PC will have to be established twice (each time via a different port). It should also be noted that the **ControlWave/ControlWaveEXP** communication port that is connected to the PC (RS-232, RS-485 or Ethernet) must be good for WINDIAG to run the Communications Diagnostics

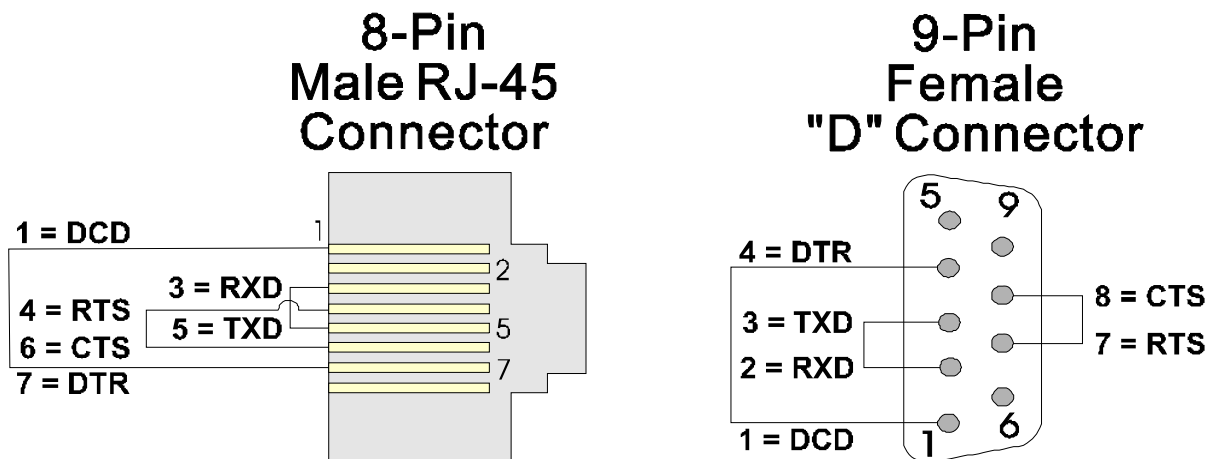

Figure 3-10 - RS-232 Loop-back Plugs

3.5.1.2 COM 1, 2, 3, 4 External Loop-back Test Procedure

1. Connect an external loop-back plug to the CPU Port to be tested, i.e., J2 of CPU for Port 1, J3 of CPU for Port 2, J2 of SCB for Port 3, or J3 of SCB for Port 4 (see Figures 3-10 through 3-12).

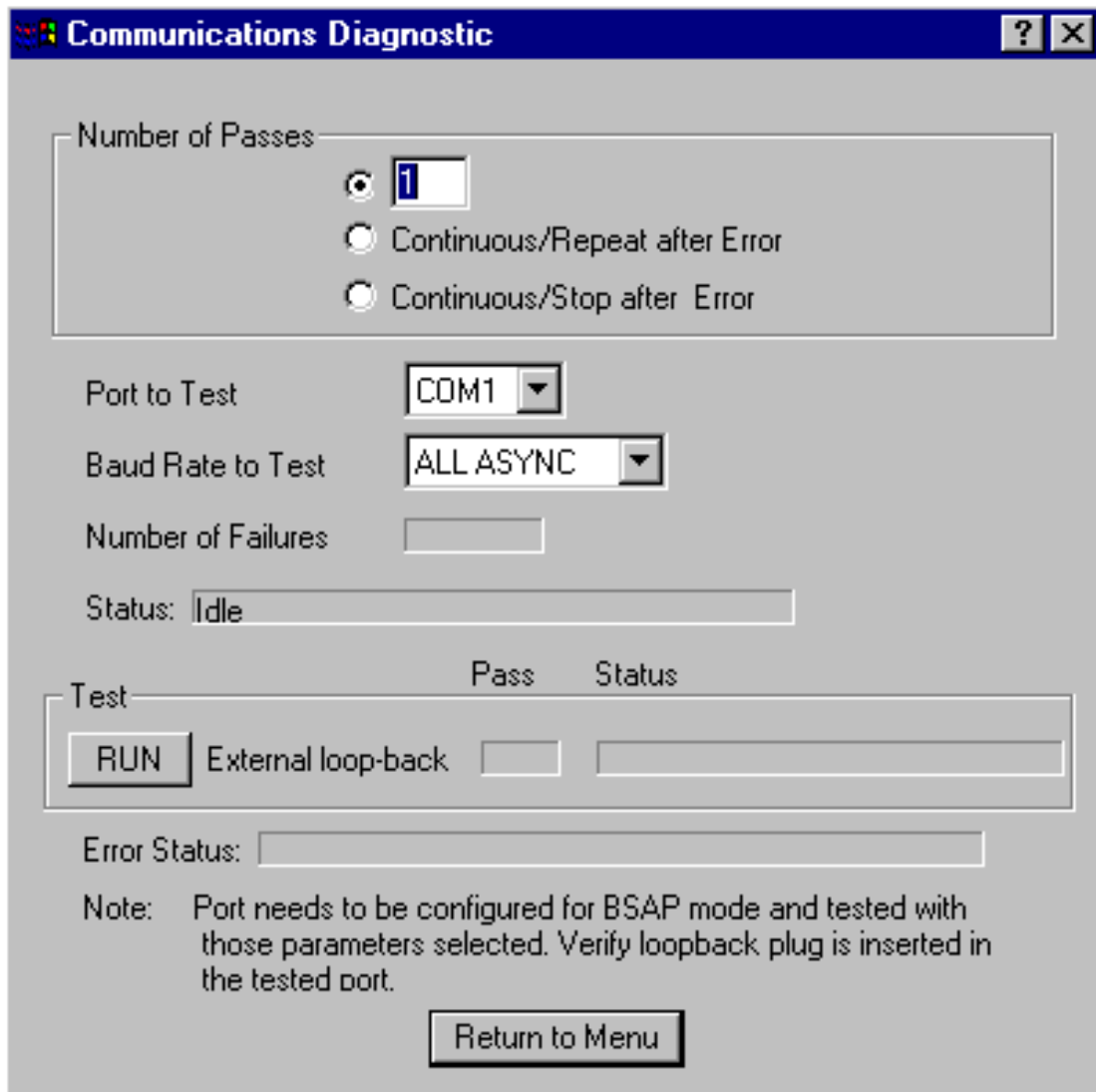

Figure 3-11 - WINDIAG's Communications Diagnostic Menu

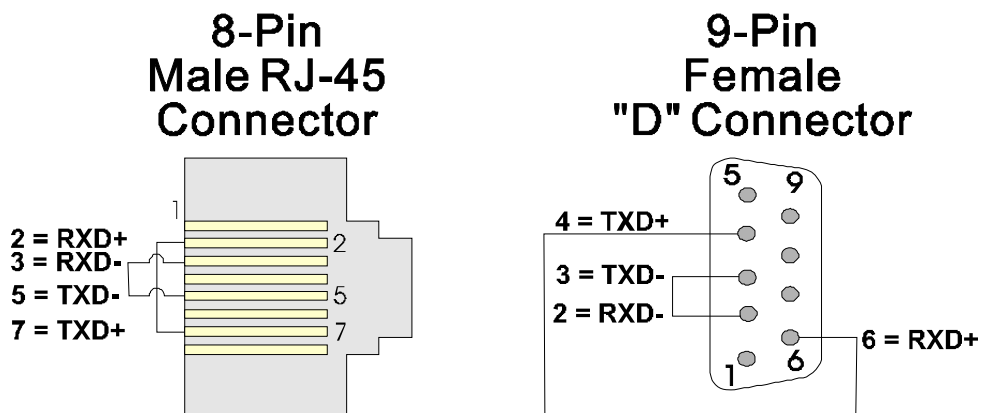

Figure 3-12 - RS-485 Loop-back Plugs

2. Type "1," "2," "3," or "4" for the port to test.
3. Set baud rate to test to 115200 baud or ALL ASYNC and the number of passes to 5.
4. Click on RUN button next to External loop-back.
 - Test responses:
 - a) Success - All sections of test passed
 - b) Failure - TXD RXD Failure
 - CTS RTS Failure
 - Execution time < 5 sec.

3.6 TROUBLESHOOTING REDUNDANCY PROBLEMS

There are several conditions, which can prevent the redundancy set-up from functioning. Some relate to configuration errors in the redundancy set-up itself, others relate to conditions, which cause the Standby to not be ready to take over if a failure occurs.

Some of the possible conditions that prevent redundancy from working include:

- Bulk Power loss at the CWREDIO unit (or a catastrophic failure at CWREDIO unit) will result in the CWREDIO's A_system relays closing and B_system relays opening. When this occurs, CW_A becomes the on-line MASTER. CW_B can't control the process since its I/O and Comm. Ports 1 through 4 are switched out.
- A/B unit DIP switches set improperly. These need to be set to opposite values; i.e. one CPU must be the "A" unit, and the other must be the "B" unit; you must never have two "A" units or two "B" units.
- Switch settings at CW_A and CW_B must be correct. See Section 2.3.3.1 of CI-ControlWave, or CI-Control-WaveEXP for details.
- Mismatch between the "A" and "B" unit (or between boot project in the standby unit and executing project in the on-line unit) with respect to Port configuration parameters, historical parameters, soft switch parameters, IP routing parameters, or application parameters. Any time an update is made to Flash parameters in the on-line unit, the same changes should be saved to the backup, or a mismatch will exist the next time the units are booted. NOTE: It is possible to configure system variables which allow certain mismatches to exist, without preventing redundant operation (errors are treated as warnings.) See the **[Ignore]** button in the 'Redundancy' page of the System Variable Wizard.
- A mismatch in Historical configuration or data (audit/ archive) can result in the standby unit, never being ready to take over for the on-line unit. This would be indicated by the on-line unit operating correctly, but the standby unit continuously cycling through the sequence 'BD', 'BC', 'BA', 'BD'. To correct this problem, the procedure, shown below, must be followed:
- CW_A and CW_B IP address are set the same. IP addresses at these units must be different or side-loading and A/B unit data exchange can't occur.

PROCEDURE FOR CORRECTING CONFIGURATION MISMATCHES

Indication: Standby unit never stays at 'BA', it continually cycles through 'BD', 'BC', possibly 'BA' and back to 'BD.'

Note: For this procedure, we are assuming "A" is the on-line unit, and "B" is the standby; if the converse is true, reverse the letters.

Note: The sequence shown herein is critical; the steps must be performed in the order shown.

Step	Unit A – Online Unit	Unit B – Standby Unit
1.	<ul style="list-style-type: none"> Power OFF this unit. 	
2.		<ul style="list-style-type: none"> Power OFF this unit.
3.		<ul style="list-style-type: none"> Power ON this unit (it should now go on-line).
4.		<ul style="list-style-type: none"> Start the Flash Configuration Utility (from within LocalView/NetView). On the 'Archives' page, remove all of the archive files. On the 'Audit' page, set the number of alarms and events both to 0. Then choose [Save to Rtu]. DO NOT save changes to the NETDEF file. Exit the Flash Configuration utility.
5.		<ul style="list-style-type: none"> Power OFF this unit.
6.	<ul style="list-style-type: none"> Power ON this unit. 	
7.	<ul style="list-style-type: none"> Start the Flash Configuration Utility. Choose [Load From RTU]. Choose [Save to NetDef] and/or [Write Profile]. Power OFF this unit, but leave the Flash Configuration Utility running. 	
8.		<ul style="list-style-type: none"> Power ON this unit.
9.		<ul style="list-style-type: none"> Choose [Save to Rtu]. This effectively transfers the historical configuration.
10.		<ul style="list-style-type: none"> Power OFF this unit.
11.	<ul style="list-style-type: none"> Verify that the "B" unit is OFF. (See Step 10.) Power ON the "A" unit. 	
12.		<ul style="list-style-type: none"> Power ON this unit, it will receive a side-load of all data from the on-line unit. 'BA' (without repeated cycles of 'BD', 'BC') indicates success.

3.7 ControlWaveREDIO FUNCTIONAL TESTS

Tests provided herein allow the user to verify the proper functionality of the **ControlWave REDIO**.

- Basic Reset and Supervisory Power-Up Test (Section 3.7.1)
- Redundant Power Source and Supervisory Power-Up Tests (Section 3.7.2)
- Watchdog Mechanism Power-Up Tests (Section 3.7.3)
- Primary CPU Selection on Power-Up Tests (Section 3.7.4)
- Tests of Switchover from 'Dead' Primary Selected Unit on Power-Up (Section 3.7.5)
- Forced Primary CPU Selection on Power-Up Tests (Section 3.7.6)

- Normal Power-Up and Switchover Tests (Section 3.7.7)
- Normal Power-Up and Forced Switchover Tests (Section 3.7.8)
- On-Line Relay Functional Tests (Section 3.7.9)
- Communication Ports Functional Tests (Section 3.7.10)

3.7.1 Basic Reset and Supervisory Power-Up Tests

Initial conditions: PSMM A switch = ON; PSMM B switch = ON; Ext Supply Pwr = OFF
Turn External Supply Power ON
A & B Power System Status LED's should initially be RED
After approximately 1 second, both Power System Status LED's should change to GREEN

3.7.2 Redundant Power Source & Supervisory Power-Up Tests

Initial conditions: Resume from last test; Both Power System Status LED's should be GREEN
Turn PSMM A OFF
A Power System Status LED should remain GREEN
Turn PSMM A ON
A Power System Status LED should remain GREEN
Turn PSMM B OFF
B Power System Status LED should remain GREEN
Turn PSMM B ON
B Power System Status LED should remain GREEN

3.7.3 Watchdog Mechanism Power-Up Tests

Initial conditions: PSMM A switch = ON; PSMM B switch = ON; Ext Supply Pwr = OFF; A/B Enabled Switch = AUTO (center position) Ext. Supply Pwr for CW_A/CWEXP-A and CW_B/CWEXP_B = OFF
Turn External Supply Power ON (at redundant units and CWREDIO)
UNIT A & UNIT B Fail LED's should initially be RED
After both redundant CPU's go through self-test, the primary CPU should go on-line, the appropriate ON_LINE LED should turn GREEN, the backup unit should be side loaded from the primary and both UNIT A & UNIT B FAIL LED's should go OFF
At CW_A/CWEXP-A, turn PSSM A OFF; If CPU A was previously on-line, then CPU B should go on-line when PSSM A is turned off; If CPU B was previously on-line, it will remain on-line.
UNIT A FAIL LED should change to RED; UNIT B FAIL LED should remain OFF
At CW_A/CWEXP-A, turn PSSM A ON
After CPU A completes self-test, it should be side loaded from the primary CPU (B); (A CPU Display = BD -> BC -> BA)
UNIT A FAIL LED should change to OFF; UNIT B FAIL LED should remain OFF
At CW_B/CWEXP-B, Turn PSSM B OFF; CPU A should go on-line
UNIT B FAIL LED should change to RED; UNIT A Fail LED should remain OFF
At CW_B/CWEXP-B, turn PSSM B ON
After CPU B completes self-test, it should be side loaded from the primary CPU (A); (B CPU Display = BD -> BC -> BA)
UNIT B FAIL LED should change to OFF; UNIT A FAIL LED should remain OFF

3.7.4 Primary CPU Selection on Power-Up Tests

Initial conditions: PSMM A switch = ON; PSMM B switch = ON; Ext Supply Pwr = OFF; A/B Primary Switch = A; A/B Enabled Switch = AUTO (center position) Ext. Supply Pwr for CW_A/CWEXP-A and CW_B/CWEXP_B = OFF
Turn External Supply Power ON (at redundant units and CWREDIO)
Initially: A FAIL LED = RED, B FAIL LED = RED; A ON-LINE LED = GREEN, B On-Line LED = OFF
After CPU A completes self-test, the UNIT A FAIL LED should go OFF
After CPU B completes self-test, it should be side loaded from the primary CPU (A); (B CPU Display = BD -> BC -> BA)
UNIT B FAIL LED should go OFF and B ON-LINE LED should remain OFF
Initial conditions: PSMM A switch = ON; PSMM B switch = ON; Ext Supply Pwr = OFF; A/B Primary Switch = B; A/B Enabled Switch = AUTO (center position) Ext. Supply Pwr for CW_A/CWEXP-A and CW_B/CWEXP_B = OFF
Turn External Supply Power ON (at redundant units and CWREDIO)
Initially: A FAIL LED = RED, B FAIL LED = RED; A ON-LINE LED = OFF, B ON-LINE LED = GREEN
After CPU B completes self-test, UNIT B FAIL LED should go OFF
After CPU A completes self-test, it should be side loaded from the primary CPU (B); (A CPU Display = BD -> BC -> BA)
UNIT A FAIL LED should go OFF and A ON-LINE LED should remain OFF

3.7.5 Tests of Switchover from “Dead” Primary Selected Unit on Power-Up

Initial conditions: A/B Primary Switch = A; A/B Enabled Switch = AUTO (center) PSMM A switch = ON; PSMM B switch = ON; Ext Supply Pwr = OFF; CW/CWEXP_A PSSM A switch = OFF; CW/CWEXP_B PSSM B switch = ON; Ext. Supply Pwr for CW/CWEXP_A and CW/CWEXP_B = OFF
Turn External Supply Power ON (at redundant units and CWREDIO)
Initially: UNIT A FAIL LED = RED, UNIT B FAIL LED = RED; UNIT A ON-LINE LED = GREEN, UNIT B ON-LINE LED = OFF
A Fail LED remains RED as PSSM A is OFF
CPU B should complete self-test, but can't be side loaded from the primary CPU (A) since A is powered down; CPU B should display BD; UNIT B Fail LED should remain RED
The unit will attempt to bring CPU B on-line:
UNIT B ON-LINE LED should change to GREEN & UNIT A ON-LINE LED should change to OFF
CPU B should run its self-test; After B completes self-test, UNIT B Fail LED should go OFF (CPU B is now on-line); UNIT A Fail LED should remain RED & UNIT A ON-LINE LED should remain OFF
Restore CPU A CPU
Turn PSSM A ON
Initially: UNIT A FAIL LED = RED; UNIT A ON-LINE LED should remain OFF
After CPU A completes self-test, it should be side loaded from the primary CPU (B); (A CPU Display = BD -> BC -> BA)
UNIT A FAIL LED should go OFF and UNIT A On-Line LED should remain OFF
Initial conditions: A/B Primary Switch = B; A/B Enabled Switch = AUTO (center) PSMM A switch = ON; PSMM B switch = ON; Ext Supply Pwr = OFF; CW/CWEXP_A PSSM A switch = ON; CW/CWEXP_B PSSM B switch = OFF; Ext. Supply Pwr for CW/CWEXP_A and CW/CWEXP_B = OFF

Turn External Supply Power ON (at redundant units and CWREDIO)
Initially: A UNIT FAIL LED = RED, B UNIT FAIL LED = RED; A ON-LINE LED = OFF, B ON-LINE LED = OFF
B FAIL LED remains RED as PSSM B is off
CPU B should complete self-test, but cannot be side loaded from the primary CPU (A) because B is powered down; CPU A should display BD; UNIT A Fail LED should remain RED
The unit will attempt to bring CPU A on-line:
UNIT A ON-LINE LED should change to GREEN & UNIT B ON-LINE LED should change to OFF
CPU A should run its self-test; After A completes self-test, UNIT A FAIL LED should go OFF (CPU A is now on-line); UNIT B Fail LED should remain RED & UNIT B ON-LINE LED should remain OFF
Restore B CPU
Turn PSSM B ON
Initially: UNIT B FAIL LED = RED; UNIT B ON-LINE LED should remain OFF
After CPU B completes self-test, it should be side loaded from the primary CPU (A); (B CPU Display = BD -> BC -> BA)
UNIT B FAIL LED should go OFF and UNIT B ON-LINE LED should remain OFF

3.7.6 Forced Primary CPU Selection on Power-Up Tests

Initial conditions: A/B Primary Switch = A; A/B Enabled Switch = B (right position) PSMM A switch = ON; PSMM B switch = ON; Ext Supply Pwr = OFF; A/B CW/CWEXP_A PSSM A switch = ON; CW/CWEXP_B PSSM B switch = ON; Ext. Supply Pwr for CW/CWEXP_A and CW/CWEXP_B = OFF
Turn External Supply Power ON (at redundant units and CWREDIO)
Initially: UNIT A FAIL LED = RED, UNIT B FAIL LED = RED; UNIT A ON-LINE LED = OFF, UNIT B ON-LINE LED = GREEN
After CPU B completes self-test, UNIT B FAIL LED should go OFF
After CPU A completes self-test, it should be side loaded from the primary CPU (B); (A CPU Display = BD -> BC -> BA)
UNIT A FAIL LED should go OFF and UNIT A ON-LINE LED should remain OFF
Turn PSSM B OFF
UNIT B FAIL LED should go ON and UNIT B ON-LINE LED should remain GREEN
Turn PSSM B ON
After CPU B completes self-test, UNIT B FAIL LED should go OFF
UNIT B On-Line LED should remain GREEN
Initial conditions: A/B Primary Switch = B; A/B Enabled Switch = A (left position) PSMM A switch = ON; PSMM B switch = ON; Ext Supply Pwr = OFF; A/B CW/CWEXP_A PSSM A switch = ON; CW/CWEXP_B PSSM B switch = ON; Ext. Supply Pwr for CW/CWEXP_A and CW/CWEXP_B = OFF
Turn External Supply Power ON (at redundant units and CWREDIO)
Initially: UNIT A FAIL LED = RED, UNIT B FAIL LED = RED; UNIT A ON-LINE LED = GREEN, UNIT B ON-LINE LED = OFF
After CPU A completes self-test, UNIT A FAIL LED should go OFF
After CPU B completes self-test, it should be side loaded from the primary CPU (A); (B CPU Display = BD -> BC -> BA)
UNIT B FAIL LED should go OFF and UNIT B ON-LINE LED should remain OFF
Turn PSSM A OFF
UNIT A FAIL LED should go ON and UNIT A ON-LINE LED should remain GREEN
Turn PSSM A ON
After CPU A completes self-test, UNIT A FAIL LED should go OFF
UNIT A ON-LINE LED should remain GREEN

3.7.7 Normal Power-Up & Switchover Tests

Initial conditions: A/B Primary Switch = A; A/B Enabled Switch = AUTO (center position) PSMM A switch = ON; PSMM B switch = ON; Ext Supply Pwr = OFF; CW/CWEXP_A PSSM A switch = ON; CW/CWEXP_B PSSM B switch = ON; Ext. Supply Pwr for CW/CWEXP_A and CW/CWEXP_B = OFF
Turn External Supply Power ON (at redundant units and CWREDIO)
Initially: UNIT A FAIL LED = RED, UNIT B FAIL LED = RED; UNIT A ON-LINE LED = GREEN, B UNIT ON-LINE LED = OFF
After CPU A completes self-test, the UNIT A FAIL LED should go OFF
After CPU B completes self-test, it should be side loaded from the primary CPU (A); (B CPU Display = BD -> BC -> BA)
UNIT B FAIL LED should go OFF and UNIT B ON-LINE LED should remain OFF
Turn PSSM A OFF
UNIT B ON-LINE LED should change to GREEN, UNIT A ON-LINE LED should change to OFF & UNIT A FAIL LED should change to RED
Turn PSSM A ON
After CPU A completes self-test, it should be side loaded from the primary CPU (B); (A CPU Display = BD -> BC -> BA)
UNIT A FAIL LED should go OFF and UNIT A ON-LINE LED should remain OFF
Turn PSSM B OFF
UNIT A ON-LINE LED should change to GREEN, UNIT B ON-LINE LED should change to OFF & UNIT B FAIL LED should change to RED
Turn PSSM B ON
After CPU B completes self-test, it should be side loaded from the primary CPU (A); (B CPU Display = BD -> BC -> BA)
UNIT B FAIL LED should go OFF and UNIT B ON-LINE LED should remain OFF
Initial conditions: A/B Primary Switch = B; A/B Enabled Switch = AUTO (center position) PSMM A switch = ON; PSMM B switch = ON; Ext Supply Pwr = OFF; CW/CWEXP_A PSSM A switch = ON; CW/CWEXP_B PSSM B switch = ON; Ext. Supply Pwr for CW/CWEXP_A and CW/CWEXP_B = OFF
Turn External Supply Power ON (at redundant units and CWREDIO)
Initially: UNIT A FAIL LED = RED, UNIT B FAIL LED = RED; UNIT A ON-LINE LED = OFF, UNIT B ON-LINE LED = GREEN
After CPU B completes self-test, the UNIT B FAIL LED should go OFF
After CPU A completes self-test, it should be side loaded from the primary CPU (B); (A CPU Display = BD -> BC -> BA)
UNIT A FAIL LED should go OFF and UNIT A ON-LINE LED should remain OFF
Turn PSSM B OFF
UNIT A ON-LINE LED should change to GREEN, UNIT ON-LINE LED should change to OFF & UNIT B FAIL LED should change to RED
Turn PSSM B ON
After CPU B completes self-test, it should be side loaded from the primary CPU (A); (B CPU Display = BD -> BC -> BA)
UNIT B FAIL LED should go OFF and UNIT B ON-LINE LED should remain OFF
Turn PSSM A OFF
UNIT B ON-LINE LED should change to GREEN, UNIT A ON-LINE LED should change to OFF & UNIT A FAIL LED should change to RED
Turn PSSM A ON
After CPU A completes self-test, it should be side loaded from the primary CPU (B); (A CPU Display = BD -> BC -> BA)
UNIT A FAIL LED should go OFF and UNIT A ON-LINE LED should remain OFF

3.7.8 Normal Power-Up & Forced Switchover Tests

Initial conditions: A/B Primary Switch = A; A/B Enabled Switch = AUTO (center position) PSMM A switch = ON; PSMM B switch = ON; Ext Supply Pwr = OFF; CW/CWEXP_A PSSM A switch = ON; CW/CWEXP_B PSSM B switch = ON; Ext. Supply Pwr for CW/CWEXP_A and CW/CWEXP_B = OFF
Turn External Supply Power ON (at redundant units and CWREDIO)
Initially: UNIT A FAIL LED = RED, UNIT B FAIL LED = RED; UNIT A ON-LINE LED = GREEN, UNIT B ON-LINE LED = OFF
After CPU A completes self-test, the UNIT A FAIL LED should go OFF
After CPU B completes self-test, it should be side loaded from the primary CPU (A); (B CPU Display = BD -> BC -> BA)
UNIT B FAIL LED should go OFF and UNIT B ON-LINE LED should remain OFF
Change A/B Enabled Switch to B (right position): Force Switchover to B
UNIT B ON-LINE LED should change to GREEN, UNIT A ON-LINE LED should change to OFF & UNIT A FAIL LED should change to RED
After CPU A completes self-test, it should be side loaded from the primary CPU (B); (A CPU Display = BD -> BC -> BA)
UNIT A FAIL LED should go OFF and UNIT A ON-LINE LED should remain OFF
Change A/B Enabled Switch to A (left position): Force Switchover to A
UNIT A ON-LINE LED should change to GREEN, UNIT B ON-LINE LED should change to OFF & UNIT B FAIL LED should change to RED
After CPU B completes self-test, it should be side loaded from the primary CPU (A); (B CPU Display = BD -> BC -> BA)
UNIT B FAIL LED should go OFF and UNIT B ON-LINE LED should remain OFF
Initial conditions: A/B Primary Switch = B; A/B Enabled Switch = AUTO (center position) PSMM A switch = ON; PSMM B switch = ON; Ext Supply Pwr = OFF; CW/CWEXP_A PSSM A switch = ON; CW/CWEXP_B PSSM B switch = ON; Ext. Supply Pwr for CW/CWEXP_A and CW/CWEXP_B = OFF
Turn External Supply Power ON (at redundant units and CWREDIO)
Initially: UNIT A FAIL LED = RED, UNIT B FAIL LED = RED; UNIT A ON-LINE LED = OFF, UNIT B ON-LINE LED = GREEN
After CPU B completes self-test, the UNIT B FAIL LED should go OFF
After CPU A completes self-test, it should be side loaded from the primary CPU (B); (A CPU Display = BD -> BC -> BA)
UNIT A FAIL LED should go OFF and UNIT A ON-LINE LED should remain OFF
Change A/B Enabled Switch to A (left position): Force Switchover to A
UNIT A ON-LINE LED should change to GREEN, UNIT B ON-LINE LED should change to OFF & UNIT B FAIL LED should change to RED
After CPU B completes self-test, it should be side loaded from the primary CPU (A); (B CPU Display = BD -> BC -> BA)
UNIT B FAIL LED should go OFF and UNIT B ON-LINE LED should remain OFF
Change A/B Enabled Switch to B (right position): Force Switchover to B
UNIT B ON-LINE LED should change to GREEN, UNIT A ON-LINE LED should change to OFF & UNIT A FAIL LED should change to RED
After CPU A completes self-test, it should be side loaded from the primary CPU (B); (A CPU Display = BD -> BC -> BA)
UNIT A FAIL LED should go OFF and UNIT A ON-LINE LED should remain OFF

3.7.9 On-Line Relay Functional Tests

The IORC Module has two sets of isolated relay contacts that indicate (by being closed) which of the pair of CPU modules is currently on-line. Terminal block plug TB2 on the IORCM panel gives access to the relay contacts for test using the following procedure. Refer

to Figure 3.2 for connector and pin identification. An ohmmeter or continuity indicator may be used to check relay status.

Initial conditions: A/B Primary Switch = A; A/B Enabled Switch = A (left position) PSMM A switch = ON; PSBM B switch = ON; Ext Supply Pwr = OFF; CW/CWEXP_A PSSM A switch = ON; CW/CWEXP_B PSSM B switch = ON; Ext. Supply Pwr for CW/CWEXP_A and CW/CWEXP_B = OFF
Check continuity between TB2-1 & TB2-2; there should be continuity indicating CPU A is on-line
Check continuity between TB2-3 & TB2-4; there should be no continuity indicating CPU B is not on-line
Turn External Supply Power ON (at redundant units and CWREDIO)
UNIT A ON-LINE LED should be ON
Check continuity between TB2-1 & TB2-2; there should be continuity indicating CPU A is on-line
Check continuity between TB2-3 & TB2-4; there should be no continuity indicating CPU B is not on-line
Change A/B Enabled Switch to B (right position): Force Switchover to B
UNIT B ON-LINE LED should be ON
Check continuity between TB2-1 & TB2-2; there should be no continuity indicating CPU A is not on-line
Check continuity between TB2-3 & TB2-4; there should be continuity indicating CPU B is on-line

3.7.10 I/O Redundancy Control Module Comm. Ports Functional Tests

3.7.10.1 Configuration for Port Tests

Associated CPU modules (A and B) must be configured to run diagnostics prior to using the following procedure (see Section 3.5). SW1-8 on each must be set to the “OFF” position to enable diagnostics.

An RS232 cable must be connected between CWIORCM port COM1 (J1) and the PC configured with **ControlWave** diagnostics (WINDIAG) and Open BSI Tools. Successful interaction between the diagnostic tools and the testing of remaining ports COM2 through COM4 will serve as test validation of COM1 switching through the CCRS. Refer to Sections 3.5.1.1 & 3.5.1.2 for required setup. (Note: PC connection to CCRS COM1 is preferable in the tests described here).

Ports COM1 and COM 2 are always RS232 level, while COM3 and COM4 may be either RS232 or RS485 dependent on the hardware assembly chosen. In the tests that follow, utilize the appropriate loopback plugs (RS-232 or RS-485) and IORCM/PC cables based on the type of port to be tested.

The IORC Module will switch the communication ports of the CPU currently on-line to the set of connectors on its front panel. During first pass testing, the CCRS A/B Enabled switch should be placed in the “A” position to force CPU A on-line and to run the serial com diagnostics via interaction with the Open BSI Tools. When ports COM2, 3 and 4 have been successfully tested, the switch should be moved to the “B” position and all tests should be repeated for on-line CPU B.

3.7.10.2 Communication Port Switching Tests

Reference Section 3.5 through 3.5.1.1 for Assistance and Figure 3-2
Establish communication between Open BSI Tools (NetView or LocalView) and the selected CCRS CPU on port COM1
Bring up diagnostics (WINDIAG) and select the Communications Diagnostic test
Select the port to be tested (B = COM2, C = COM3, D = COM4), the number of passes (enter "25") and the Baud Rate (select 38.4 Kbps). Place the required loopback plug on the port under test and click on the "RUN" button in the diagnostic window. If the port paths are properly switched and all hardware is functional, the status display will contain the message "Success" and the diagnostic should run for 25 passes before the status message displays "Idle".
Repeat the tests for all ports
Repeat all of the above after the alternate CPU is placed on-line with the A/B Enabled switch

Section 4

SPECIFICATIONS

4.1 ControlWave I/O REDUNDANCY CONTROL MODULE

4.1.1 I/O Redundancy Control Module General Specifications

Overview: See Section 1.5.4

Operator Controls: Key Operated A/B ENABLED Mode Select Switch - SW1
See Section 1.5.4.2
A/B PRIMARY Select Switch - SW2
See Section 1.5.4.2

LEDs: See Table 4-1

Table 4-1 - IORC Module LEDs

LED Name	LED Color	Function
CR1 - Unit A On-Line	Green	GREEN = CW_A is On-line as Primary Controller
CR2 - Unit B On-Line	Green	GREEN = CW_B is On-line as Primary Controller
CR3 - Unit A Fail	Red	RED = CW_A Watchdogged (failed)
CR4 - Unit B Fail	Red	RED = CW_B Watchdogged (failed)
CR5 - B Power System Status	Red Green	GREEN = +3.3V4, VCC_RED, RED_RLY PWR OK RED = At least one of the above supplies has failed
CR6 - A Power System Status	Red Green	GREEN = +3.3V1, +3.3V2, +3.3V3 are OK RED = At least one of the above supplies has failed

Backplane Intf. Connector: 132-pin CPCI style Jack J2 (mates with Backplane Connector P3)

Communication Ports: See Figures 4-1, 2-3A & 2-4
See Table 4-2

Looking Into Bd. Receptacle

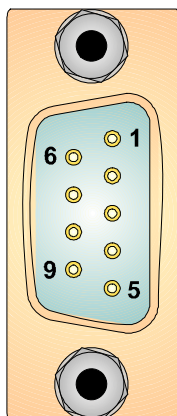

Figure 4-1 - DB9 9-Pin Connector Associated with COM1 through COM4

Table 4-2 - COM1 through COM4 Connector Pin Assignment

Pin #	Signal RS-232	Description: RS-232 Signals	Signal RS-485	Description: RS-485 Signals - COM3/4
1	DCD	Data Carrier Detect Input		N/A
2	RXD	Receive Data Input	RXD-	Receive Data - Input
3	TXD	Transmit Data Output	TXD-	Transmit Data - Output
4	DTR	Data Terminal Ready Output	TXD+	Transmit Data + Input
5	GND	Signal/Power Ground	ISOGND	Isolated Ground
6	DSR	Data Set Ready Input	RXD+	Receive Data + Output
7	RTS	Request To Send Output		N/A
8	CTS	Clear To Send Input		N/A
9	RI	Ring Indicator		N/A

Baud Rate: 300 to 115K (bps) for RS-232 or RS-485

Watchdog Inputs: 4-pin Connector TB1 (see Figure 1-10 & Table 4-3)

Online Contact Outputs: 4-pin Connector TB2 (see Figure 1-10 & Table 4-3)

Power System Status Contact Outputs: 4-pin Connector TB3 (See Figure 1-10 & Table 4-3)
Contact rating: 1 AMP @30V DC Resistive

Table 4-3 - IORCM Switch Control and Power System Status Connections

Term. Blk. Designations	Control Definitions
TB1-1	CW_A Watchdog + Input
TB1-2	CW_A Watchdog - Input
TB1-3	CW_B Watchdog + Input
TB1-4	CW_B Watchdog - Input
TB2-1	CW_A Online Contact Output
TB2-2	CW_A Online Contact Output
TB2-3	CW_A Online Contact Output
TB2-4	CW_A Online Contact Output
TB3-1	Normally OPEN; CLOSED if Power OK.
TB3-2	Normally OPEN; CLOSED if Power OK
TB3-3	Normally CLOSED; OPEN if Power OK
TB3-4	Normally CLOSED; OPEN if Power OK

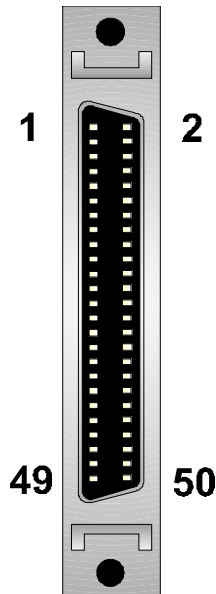

Note: System A Assigned to J5 & System B Assigned to J6

Figure 4-2 - IORCM Connectors J5 & J6

4.2 POWER SUPPLY/MONITOR MODULE

4.2.1 Input Power Specs.

Note: Voltages are dc unless otherwise specified.

Operating Range:	<u>TB2-1 (+VIN) LOGIC (dc) Supply</u> +20.7V to +30.0V (+24V Input Supply) (Shutdown occurs at +20.7V nominal)
Output Voltages:	Isolated +5.2Vdc
Output Current:	<i>Typical</i> 4A (Max.) @ +5.2Vdc
Output Ripple:	<i>With +5.2V @ 4A (Worst Case Conditions)</i> +5V Output: 50mV, 110mVpp @ 30V input
Input Current:	<i>With Supply Loading of 5.2V @ 4A</i> Vin @ +24.0V - Iin Max. 0.40A
Fusing:	3A Slow Blow 5x20mm Fuse
Electrical Isolation:	500Vdc Primary to Secondary
Surge Suppression:	500Vdc MOV, (PSGND) to CHASSIS 32V Transient Suppressor from +VIN to -VIN (PSGND) Meets IEEE Std. 472-1974
Terminations:	Pluggable, maximum wire size is 16 gauge
Shutdown:	+24V System: Max. ON Switchpoint = 20.7V

Min. OFF Switchpoint = 20.0V

Power Switch: MOSFET Driven by Switch connected to Gate

4.2.2 Power Supply/Monitor Specs.

Signals Monitored: Bulk Input Supply Voltage
Isolated Output Voltage (+5.2Vdc)

4.2.3 Power Supply Input Connector (see Figure 4-3 & Table 4-4)

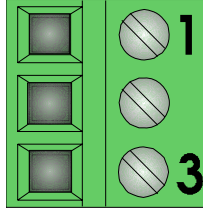

Figure 4-3 - Power Supply/Monitor Module Connector TB1

Table 4-4 - Power Supply Terminal Blocks

TERM. #	NAME	FUNCTION
TB1-1	+VIN	+20.7V to +30V (dc) Input
TB1-2	-VIN	Supply Common
TB1-3	CHASSIS	Chassis Ground

4.3 BACKPLANE PCB

Slots: 8 I/O, 1 Redundancy Control Module & 2 Power Supplies

Power: +5.2V

Connectors: 110-pin CPCI style connectors for IORCM (P3) and IORSMS (P4 through P11) (see Figure 4-4)
36-Pin Dual Inline female connectors for PSMM#1 (J1) and PSMM#2 (J2) (see Figure 4-4)

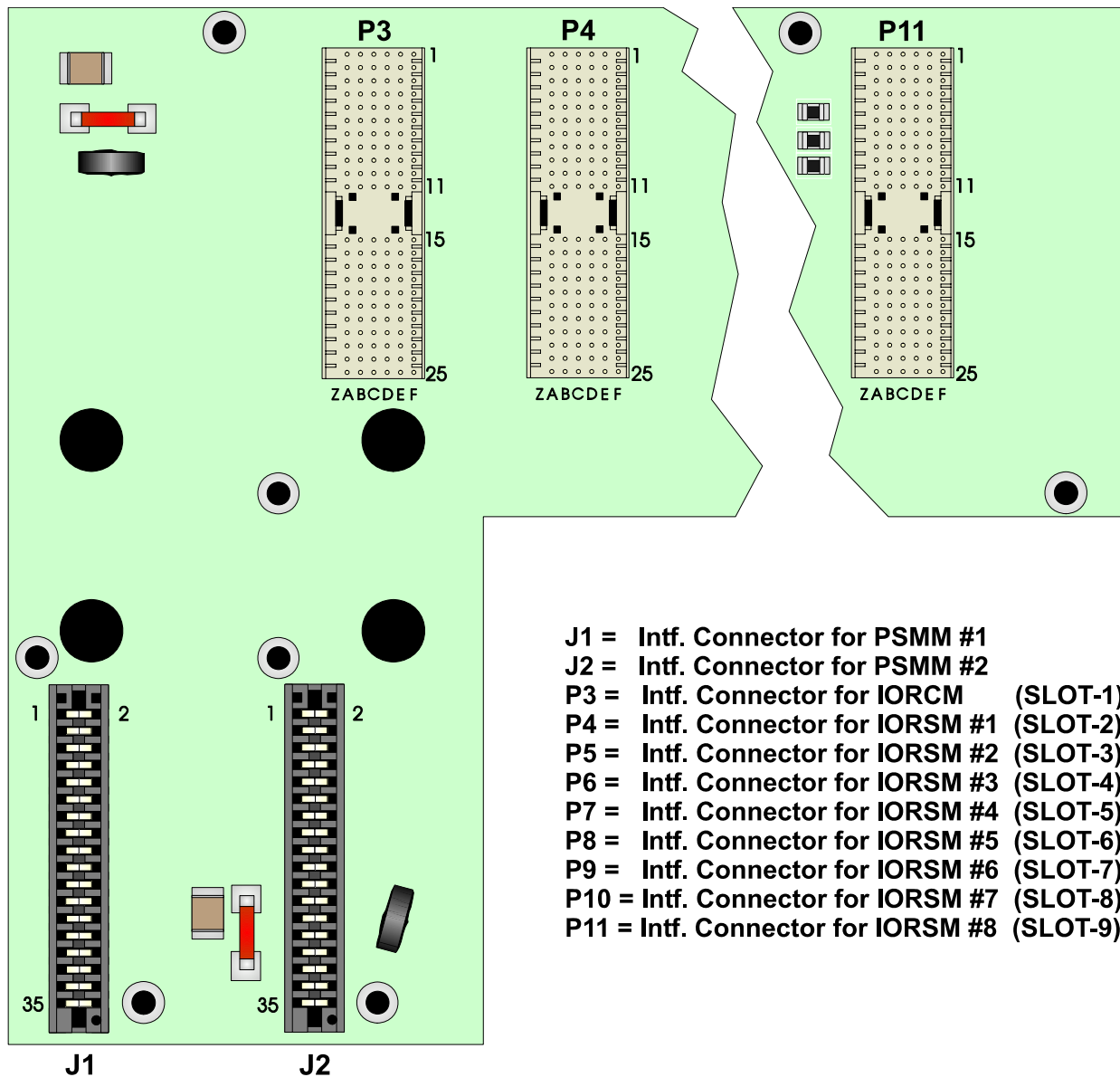

Figure 4-4 - Backplane PCB Connector Assignment

4.4 ENVIRONMENTAL SPECIFICATIONS

Temperature: Operating: -40 to +158 °F (-40 to +70 °C)
 Storage: -40 to +185 °F (-40 to +85 °C)

Relative Humidity: 15-95% Non-condensing

4.5 DIMENSIONS

CWREDIO Installation: see Figure 4-5

ASSEMBLY	DIM. A	DIM. B	DIM. C
8 I/O	18.31"	18.98"	17.70"
4 I/O	10.98"	11.65"	10.37"
2 I/O	7.31"	7.98"	6.70"

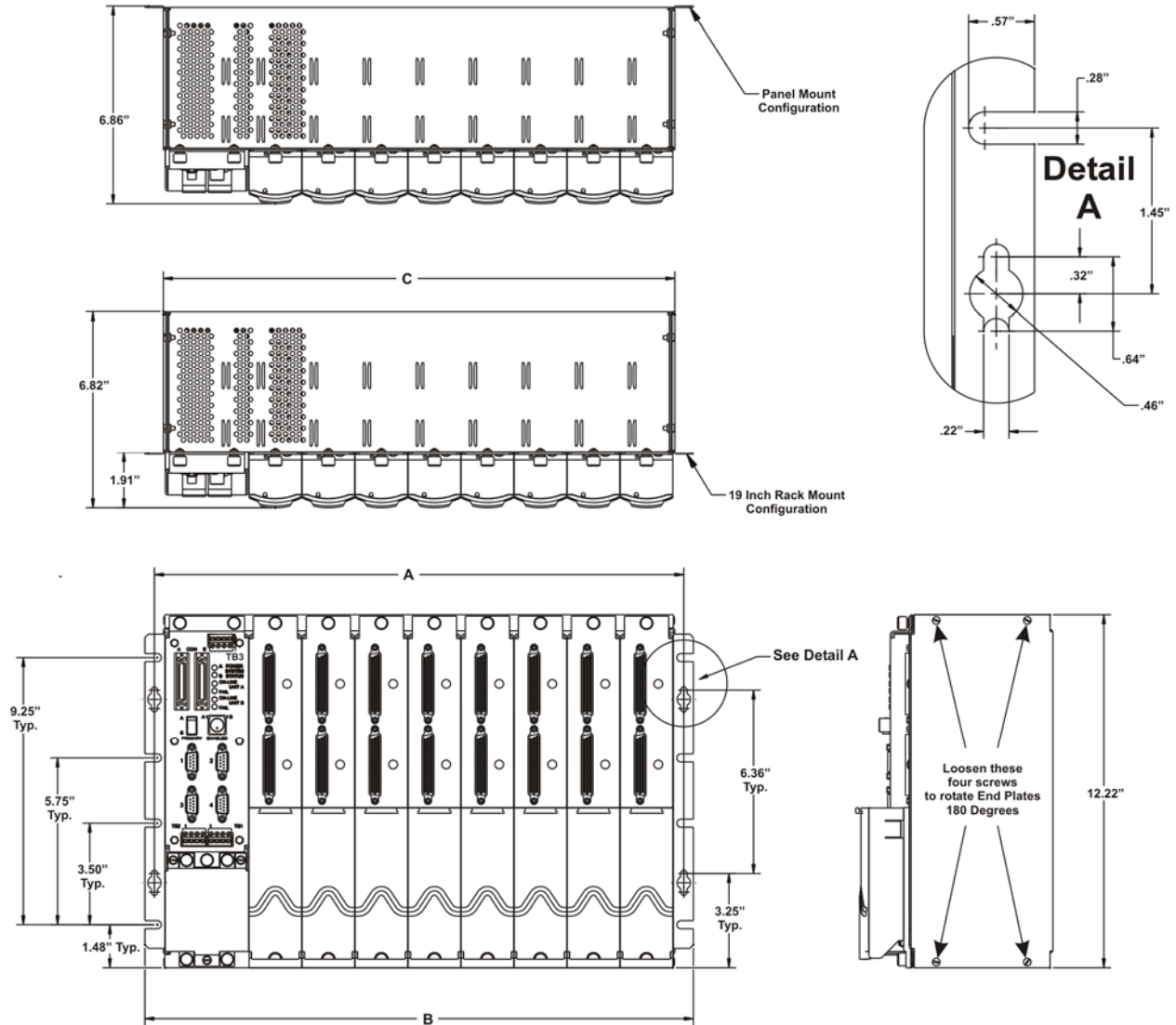

Figure 4-5 - CWREDIO Installation & Dimension Drawing

Supplement Guide - S1400CW

Issue: 04/05

ControlWave™

**SITE CONSIDERATIONS
For
EQUIPMENT INSTALLATION,
GROUNDING
&
WIRING**



A Guide for the Protection of
Site Equipment & Personnel
In the Installation of
ControlWave
Process Automation Controllers

Bristol Babcock

NOTICE
Copyright Notice

The information in this document is subject to change without notice. Every effort has been made to supply complete and accurate information. However, Bristol Babcock assumes no responsibility for any errors that may appear in this document.

Request for Additional Instructions

Additional copies of instruction manuals may be ordered from the address below per attention of the Sales Order Processing Department. List the instruction book numbers or give complete model number, serial or software version number. Furnish a return address that includes the name of the person who will receive the material. Billing for extra copies will be according to current pricing schedules.

ControlWave® is a re registered trademark of Bristol Babcock. Other trademarks or copyrighted products mentioned in this document are for information only, and belong to their respective companies, or trademark holders.

Copyright (c) 2005 Bristol Babcock, 1100 Buckingham St., Watertown, CT 06795. No part of this manual may be reproduced in any form without the express written permission of Bristol Babcock.

Supplement Guide S1400CW

SITE CONSIDERATIONS FOR EQUIPMENT INSTALLATION, GROUNDING & WIRING

TABLE OF CONTENTS

<i>SECTION</i>	<i>TITLE</i>	<i>PAGE #</i>
Section 1 - INTRODUCTION		
1.1	GENERAL INTRODUCTION	1-1
1.2	MAJOR TOPICS	1-1
Section 2 - PROTECTION		
2.1	PROTECTING INSTRUMENT SYSTEMS.....	2-1
2.1.1	Quality Is Conformance To Requirements.....	2-1
2.2	PROTECTING EQUIPMENT & PERSONNEL	2-1
2.2.1	Considerations For The Protection of Personnel.....	2-2
2.2.2	Considerations For The Protection of Equipment.....	2-2
2.3	OTHER SITE SAFETY CONSIDERATIONS.....	2-3
Section 3 - GROUNDING & ISOLATION		
3.1	POWER & GROUND SYSTEMS.....	3-1
3.2	IMPORTANCE OF GOOD GROUNDS.....	3-1
3.3	EARTH GROUND CONNECTIONS.....	3-1
3.3.1	Establishing a Good Earth Ground	3-1
3.3.1.1	Soil Conditions	3-2
3.3.1.2	Soil Types	3-2
3.3.1.3	Dry, Sandy or Rocky Soil.....	3-4
3.3.2	Ground Wire Considerations.	3-5
3.3.3	Other Grounding Considerations.	3-6
3.4	ISOLATING EQUIPMENT FROM THE PIPELINE.....	3-7
3.4.1	Meter Runs Without Cathodic Protection.....	3-7
3.4.2	Meter Runs With Cathodic Protection	3-7
Section 4 - LIGHTNING ARRESTERS & SURGE PROTECTORS		
4.1	STROKES & STRIKES	4-1
4.1.1	Chance of Being Struck by Lightning.	4-1
4.1.2	Antenna Caution	4-3
4.1.3	Ground Propagation	4-5
4.1.4	Tying it all Together	4-5
4.1.5	Impulse Protection Summary	4-5
4.2	USE OF LIGHTNING ARRESTERS & SURGE PROTECTORS.....	4-6
Section 5 - WIRING TECHNIQUES		
5.1	OVERVIEW	5-1
5.2	INSTRUMENT WIRING.	5-1
5.2.1	Common Returns.....	5-1

Supplement Guide S1400CW

SITE CONSIDERATIONS FOR EQUIPMENT INSTALLATION, GROUNDING & WIRING

TABLE OF CONTENTS

<i>SECTION</i>	<i>TITLE</i>	<i>PAGE #</i>
Section 5 - WIRING TECHNIQUES (Continued)		
5.2.2	Use of Twisted Shielded Pair Wiring (with Overall Insulation).....	5-2
5.2.3	Grounding of Cable Shields.	5-3
5.2.4	Use of Known Good Earth Grounds	5-3
5.2.5	Earth Ground Wires	5-3
5.2.6	Working Neatly & Professionally	5-3
5.2.7	High Power Conductors and Signal Wiring	5-4
5.2.8	Use of Proper Wire Size	5-4
5.2.9	Lightning Arresters & Surge Protectors	5-4
5.2.10	Secure Wiring Connections	5-5

REFERENCE DOCUMENTS

1. IEEE Recommended Practice for Grounding of Industrial and Commercial Power Systems - ANSI/IEEE Std 142-1982
2. IEEE Guide for the Installation of Electrical Equipment to Minimize Electrical Noise inputs to Controllers from External Sources - IEE Std 518-1982
3. Lightning Strike Protect; Roy B. Carpenter, Jr. & Mark N. Drabkin, Ph.D.; Lightning Eliminators & Consultant, Inc., 6687 Arapahoe Road, Boulder Colorado
4. Lightning Protection Manual for Rural Electric Systems, NRECA Research Project 82-5, Washington DC, 1983
5. Grounding for the Control of EMI; Hugh W. Denny; Don White Consultants, Inc., 1983, 1st Edition
6. Fundamentals of EGM - Electrical Installations; Michael D. Price; NorAm Gas Transmission, 525 Milam Street, Shreveport, Louisiana 71151
7. TeleFlow Modem Grounding Kit 621495-01-8 Installation Instructions - PIP-3530MGKI; Bristol Babcock, Watertown, CT 06795

Section 1 - Overview

1.1 INTRODUCTION

This document provides information pertaining to the installation of **ControlWave** systems; more specifically, information covering reasons, theory and techniques for protecting your personnel and equipment from electrical damage. Your instrument system affects the quality of service provided by your company and many aspects of its operational safety. Loss of instruments means lost production and profits as well as increased expenses.

Information contained in this document is for educational purposes. Bristol Babcock makes no warranties or guarantees on the effectiveness or the safety of techniques described herein. Where the safety of installations and personnel is concerned, refer to the National Electrical Code Rules and rules of local regulatory agencies.

1.2 MAJOR TOPICS

Topics are covered in seven sections designed to pinpoint major areas of concern for the protection of site equipment and personnel. The following overview is provided for each of the major sections.

- **Section 2 - Protection**

This section provides the reasons for protecting instrument systems. An overview of the definition of quality and what we are trying to accomplish in the protection of site installations and how to satisfy the defined requirements is presented. Additionally, this section provides considerations for the protection of personnel and equipment.

- **Section 3 - Grounding & Isolation**

Information pertaining to what constitutes a good earth ground, how to test and establish such grounds, as well as when and how to connect equipment to earth grounds is provided

- **Section 4 - Lightning Arresters & Surge Protectors**

Some interesting information dealing with Lightning strikes and strokes is presented in technical and statistical form along with a discussion of how to determine the likelihood of a lightning strike. Protecting equipment and personnel during the installation of radios and antenna is discussed in a review of the dangers to equipment and personnel when working with antennas. Reasons for the use of lightning arresters and surge protectors are presented along with overviews of how each device protects site equipment.

- **Section 5 - Wiring Techniques**

Installation of Power and “Measurement & Control” wiring is discussed. Information on obscure problems, circulating ground and power loops, bad relays, etc. is presented. Good wire preparation and connection techniques along with problems to avoid are discussed. This sections list the ten rules of instrument wiring.

Section 2 - Protection

2.1 PROTECTING INSTRUMENT SYSTEMS

Electrical instrumentation is susceptible to damage from a variety of natural and man made phenomena. In addition to wind, rain and fire, the most common types of system and equipment damaging phenomena are lightning, power faults, communication surges & noise and other electrical interference's caused by devices such as radios, welders, switching gear, automobiles, etc. Additionally there are problems induced by geophysical electrical potential & noise plus things that are often beyond our wildest imagination.

2.1.1 Quality Is Conformance To Requirements

A quality instrumentation system is one that works reliably, safely and as purported by the equipment manufacturer (and in some cases by the system integrator) as a result of good equipment design and well defined and followed installation practices. If we except the general definition of quality to be, "quality is conformance to requirements," we must also except the premise that a condition of "quality" can't exist where requirements for such an end have not been evolved. In other words, you can't have quality unless you have requirements that have been followed. By understanding the requirements for a safe, sound and reliable instrumentation system, and by following good installation practices (as associated with the personnel and equipment in question), the operational integrity of the equipment and system will be enhanced.

Understanding what is required to properly install BBI equipment in various environments, safely, and in accordance with good grounding, isolating and equipment protection practices goes a long way toward maintaining a system which is healthy to the owner and customer alike. Properly installed equipment is easier to maintain and operate, and is more efficient and as such more profitable to our customers. Following good installation practices will minimize injury, equipment failure and the customer frustrations that accompany failing and poorly operating equipment (of even the finest design). Additionally, personnel involved in the installation of a piece of equipment add to or subtract from the reliability of a system by a degree which is commensurate with their technical prowess, i.e., their understanding of the equipment, site conditions and the requirements for a quality installation.

2.2 PROTECTING EQUIPMENT & PERSONNEL

ControlWave installations must be performed in accordance with National Electrical Code Rules, electrical rules set by local regulatory agencies, and depending on the customer environment (gas, water, etc), other national, state and local agencies such as the American Water Works Association (AWWA). Additionally, installation at various customer sites may be performed in conjunction with a "safety manager" or utility personnel with HAZMAT (hazardous material) training on materials present (or potentially present) as required by OSHA, the customer, etc.

2.2.1 Considerations For The Protection of Personnel

Always evaluate the site environment as if your life depended on it. Make sure that you understand the physical nature of the location where you will be working. Table 2-1 provides a general guideline for evaluating an installation site.

Table 2-1 - Installation Site Safety Evaluation Guide

#	Guide
1	Indoor or outdoor – Dress Appropriately
2	If outdoor, what kind of environment, terrain, etc. Watch out for local varmint (bees, spiders, snakes, etc.)
3	If indoor or outdoor – determine if there are any pieces of dangerous equipment or any processes which might be a risk to your safety
4	If in a tunnel, bunker, etc. watch out for a build up of toxic or flammable gases. Make sure the air is good. Watch out for local varmint (bees, spiders, snakes, etc.)
5	Hazardous or Non-Hazardous Environment – Wear appropriate safety equipment and perform all necessary safety measures.
6	Before installing any equipment or power or ground wiring, make sure that there are no lethal (life threatening) voltages between the site where the instrument will be installed and other equipment, pipes, cabinets, etc. or to earth itself.
7	Never assume that adjacent or peripheral equipment has been properly installed and grounded. Determine if this equipment and the ControlWave unit in question can be touched simultaneously without hazard to personnel and/or equipment?
8	Before embarking to remote locations where there are few or no human inhabitants ask a few simple questions like, should I bring water, food, hygienic materials, first aid kit, etc? Be Prepared!
9	Observe the work habits of those around you – for your own safety!

Some of the items that a service person should consider before ever going on site can be ascertained by simply asking questions of the appropriate individual. Obviously other safety considerations can only be established at the installation site.

2.2.2 Considerations For The Protection of Equipment

Always evaluate the site installation/service environment and equipment. Understand the various physical interfaces you will be dealing with such as equipment mounting and supporting, **ControlWave** analog and digital circuits, power circuits, communication circuits and various electrical grounds. Table 2-2 provides a general guideline for evaluating the equipment protection requirements of an installation site.

Table 2-2 - Equipment Protection Site Safety Evaluation Guide

#	Guide	Reference Section
1	Environment - Class I, Division 2 - Nonincendive Environment - Class I, Division 1 - Intrinsically Safe Other - Safe or unrated area	See Appendix A of CI Manual See Appendix B of CI Manual
2	Earth Ground - Established by mechanical/electrical or (both) or not at all.	See Section 3
3	Is the area prone to lightning strikes?	See Section 4
4	Are there surge suppressors installed or to be installed?	See Section 4
5	Are there overhead or underground power or communication cables in the immediate area?	See Section 2.3

Table 2-2 - Equipment Protection Site Safety Evaluation Guide (Continued)

#	Guide	Reference Section
6	Is there an antenna in the immediate area?	See Section 4.1.2
7	How close is other equipment? Can someone safely touch this equipment and a ControlWave simultaneously?	See Section 2.3
8	Determine equipment ground requirements. How will the ControlWave and its related wiring be grounded? Consider Earth Ground, Circuit Ground, Conduit Ground, Site Grounds!	See Section 3
9	Are there any obviously faulty or questionable power or ground circuits?	See Section 2.3

2.3 OTHER SITE SAFETY CONSIDERATIONS

Overhead or underground power or communication cables must be identified prior to installing a new unit. Accidentally cutting, shorting or simply just contacting power, ground, communication or process control I/O wiring can have potentially devastating effects on site equipment, the process system and or personnel.

Don't assume that it is safe to touch adjacent equipment, machinery, pipes, cabinets or even the earth itself. Adjacent equipment may not have been properly wired or grounded, may be defective or may have one or more loose system grounds. Measure between the case of a questionable piece of equipment and its earth ground for voltage. If a voltage is present, something is wrong.

AC powered equipment with a conductive case should have the case grounded. If you don't see a chassis ground wire, don't assume that it is safe to touch this equipment. If you notice that equipment has been grounded to pipes, conduit, structural steel, etc., you should be leery. ***Note: AWWA's policy on grounding of electric circuits on water pipes states, "The American Water Works Association (AWWA) opposes the grounding of electrical systems to pipe systems conveying water to the customer's premises...."***

Be sure that the voltage between any two points in the instrument system is less than the stand-off voltage. Exceeding the stand-off voltage will cause damage to the instrument and will cause the instrument to fail.

Section 3 - Grounding & Isolation

3.1 POWER & GROUND SYSTEMS

ControlWaves utilize DC power systems. AC power supplies are not provided with **ControlWave** units. **ControlWave**, **ControlWave MICRO**, **ControlWave EFM/GFC/EFC**, **ControlWaveRED**, **ControlWaveREDIO** and **ControlWave I/O Expansion Racks** are provided with a Ground Lug that accommodates up to a #4 AWG size wire for establishing a connection to Earth Ground. In the case of the **ControlWaveLP**, a Chassis Ground termination terminal (TB2, Pin-3), that accepts up to a #14 AWG size wire, is provided on the unit's Power Supply/Sequencer Board.

3.2 IMPORTANCE OF GOOD GROUNDS

ControlWave units (see above) are utilized in instrument and control systems that must operate continually and within their stated accuracy over long periods of time with minimum attention. Failures resulting from an improperly grounded system can become costly in terms of lost time and disrupted processes. A properly grounded system will help prevent electrical shock hazards resulting from contact with live metal surfaces, provide additional protection of equipment from lightning strikes and power surges, minimize the effects of electrical noise and power transients, and reduce signal errors caused by ground wiring loops. Conversely, an improperly grounded system may exhibit a host of problems that appear to have no relation-ship to grounding. It is essential that the reader (service technician) have a good under-standing of this subject to prevent needless troubleshooting procedures.

WARNING

*This device must be installed in accordance with the National Electrical Code (NEC) ANSI/NEPA-70. Installation in hazardous locations must also comply with Article 500 of the code. For information on the usage of **ControlWave** units in Class I, Division 2, Groups C & D Hazardous and Nonhazardous locations, see appendix A of the applicable Customer Instruction (CI) manual. For information on the usage of **ControlWave** units in Class I, Division 1, Groups C & D Hazardous locations, see appendix B of the applicable Customer Instruction (CI) manual.*

3.3 EARTH GROUND CONNECTIONS

To properly ground a **ControlWave** unit, the units Chassis Ground (post or terminal) must ultimately be connected to a known good Earth Ground. Observe recommendations provided in topics Establishing a Good Earth Ground and Ground Wire Considerations.

3.3.1 Establishing a Good Earth Ground

A common misconception of a ground is that it consists of nothing more than a metal pipe driven into the soil. While such a ground may function for some applications, it will often

not be suitable for a complex system of sophisticated electronic equipment. Conditions such as soil type, composition and moisture will all have a bearing on ground reliability.

A basic ground consists of a 3/4-inch diameter rod with a minimum 8-foot length driven into conductive earth to a depth of about 7-feet as shown in Figure 3-1. Number 3 or 4 AWG solid copper wire should be used for the ground wire. The end of the wire should be clean, free of any coating and fastened to the rod with a clamp. This ground connection should be covered or coated to protect it from the weather and the environment.

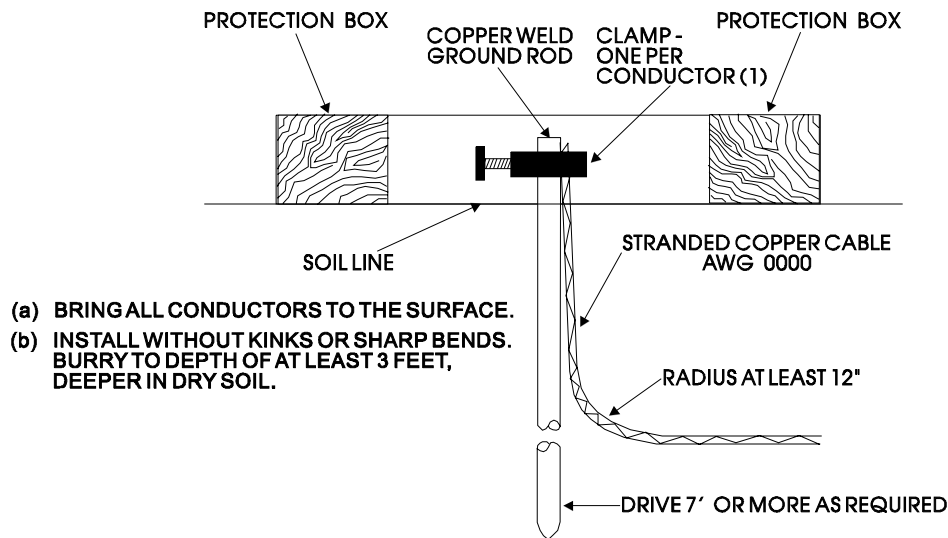

Figure 3-1 - Basic Ground Rod Installation

3.3.1.1 Soil Conditions

Before installing a ground rod, the soil type and moisture content should be analyzed. Ideally, the soil should be moist and moderately packed throughout to the depth of the ground rod. However, some soils will exhibit less than ideal conditions and will require extra attention.

Soil types can be placed into two general categories with respect to establishing and maintaining a good earth ground, i.e., ‘Good Soil’ and ‘Poor Soil.’

To be a good conductor, soil must contain some moisture and free ions (from salts in the soil). In very rainy areas, the salts may be washed out of the soil. In very sandy or arid area the soil may be too dry and/or salt free to be a good conductor. If salt is lacking add rock salt (NaCl); if the soil is dry add calcium chloride (CaCl₂).

3.3.1.2 Soil Types:

Good

Damp Loam
 Salty Soil or Sand
 Farm Land

Poor

Back Fill
 Dry Soil
 Sand Washed by a Lot of Rain
 Dry Sand (Desert)
 Rocky Soil

Ground Beds must always be tested for conductivity prior to being placed into service. A brief description of ground bed testing in ‘Good Soil’ and ‘Poor Soil’ is provided herein. Details on this test are described in the National Electrical Code Handbook. Once a reliable

ground has been established, it should be tested on a regular basis to preserve system integrity.

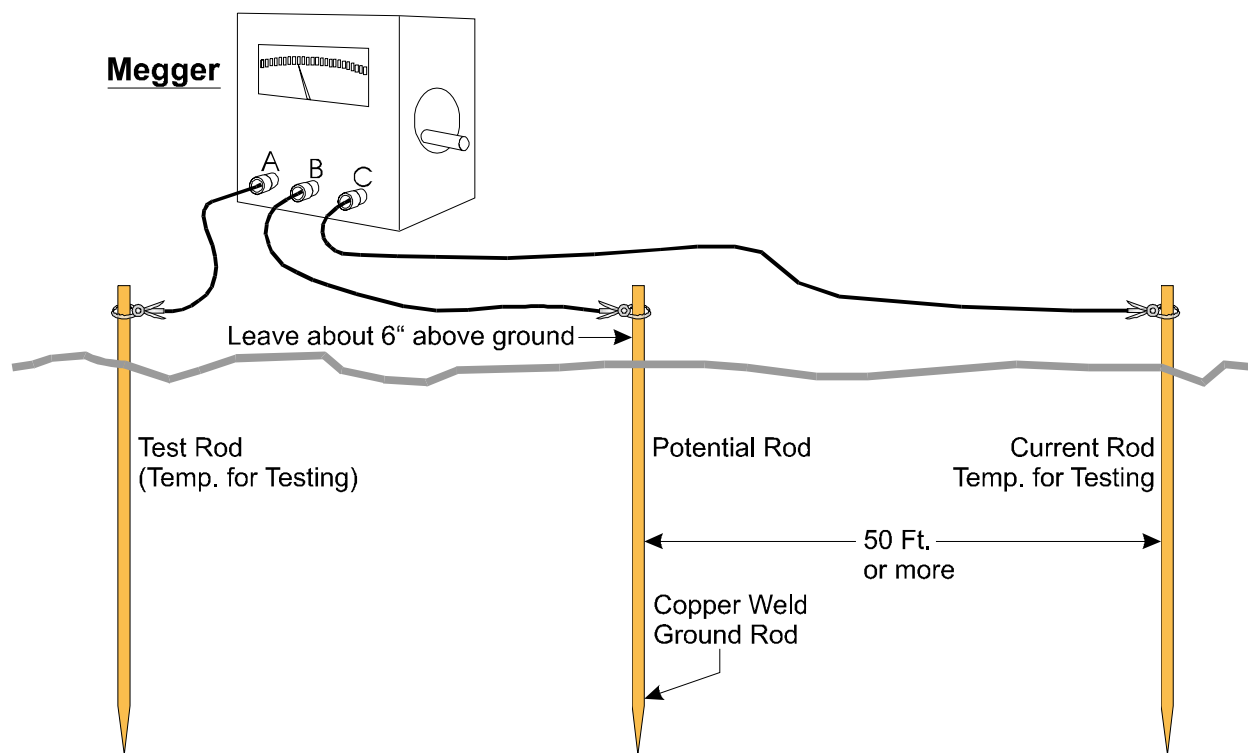

Figure 3-2 - Basic Ground Bed Soil Test Setup

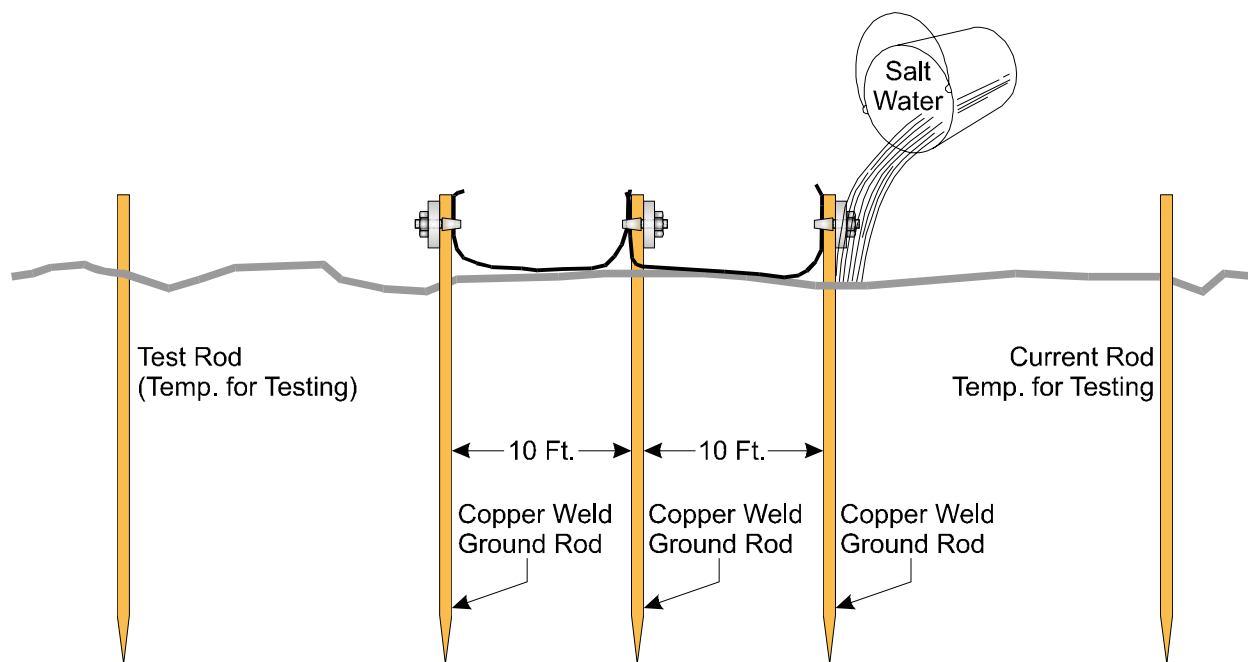

Figure 3-3 - Basic Ground Bed Soil Test Setup with Additional Ground Rods

Figure 3-2 shows the test setup for 'Good Soil' conditions. If the Megger* reads less than 5 ohms, the ground is good. The lower the resistance, the better the earth ground. If the

Megger reads more than 10 ohms, the ground is considered 'poor.' If a poor ground is indicated, one or more additional ground rods connected 10 feet from the main ground rod should be driven into the soil and interconnected via bare AWG 0000 copper wire and 1" x ¼-20 cable clamps as illustrated in Figure 3-3). * **Note: Megger is a Trademark of the Biddle Instrument Co. (now owned by AVO International). Other devices that may be used to test ground resistance are "Viboground"; Associated Research, Inc., "Groundmeter"; Industrial Instruments, Inc., and "Ground-ohmer"; Herman H. Sticht Co., Inc.**

If the Megger still reads more than 10 ohms, mix a generous amount of cooking salt, ice cream salt or rock salt with water and then pour about 2.5 to 5 gallons of this solution around each rod (including the test rods). Wait 15 minutes and re-test the soil. If the test fails, the soil is poor and a 'Poor Soil Ground Bed' will have to be constructed.

Figure 3-4 shows a typical Poor Soil Ground Bed Electrode. A Poor Soil Ground Bed will typically consists of four or more 10-foot long electrodes stacked vertically and separated by earth. Figure 3-5 shows the construction of a Poor Soil Ground Bed. For some poor soil sites, the ground bed will be constructed of many layers of 'Capacitive Couplings' as illustrated. In extremely poor soil sites one or more 3' by 3' copper plates (12 gauge or 1/16" thick) will have to be buried in place of the electrodes.

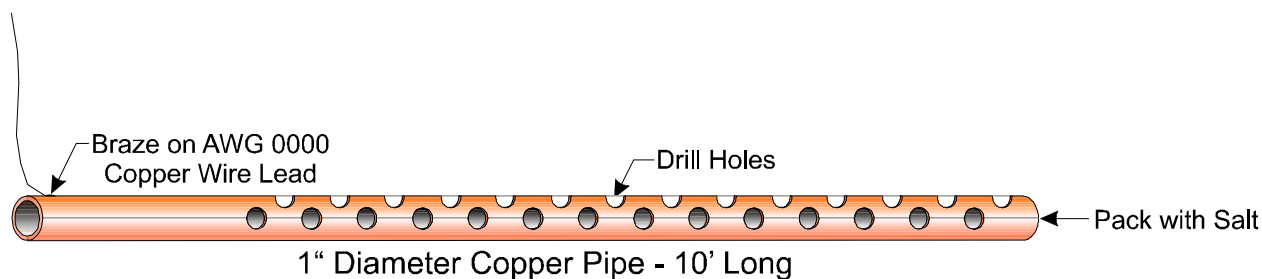

Figure 3-4 - Ground Electrode Construction for Poor Soil Conditions

3.3.1.3 Dry, Sandy or Rocky Soil

Very dry soil will not provide enough free ions for good conductance and a single ground rod will not be effective. A buried counterpoise or copper screen is recommended for these situations. It will be necessary to keep the soil moist through regular applications of water.

Sandy soil, either wet or dry, may have had its soluble salts leached out by rain water, thereby reducing conductivity of the ground. High currents from lightning strikes could also melt sand and cause glass to form around the ground rod, rendering it ineffective. A buried counterpoise or copper screen is preferred for these installations along with regular applications of salt water.

Rocky soil can pose many grounding problems. A counterpoise or copper plate will probably be required. Constructing a trench at the grounding site and mixing the fill with a hygroscopic salt such as calcium chloride may help for a time. Soaking the trench with water on a regular basis will maintain conductivity.

Units with phone modems require the use of a lightning arrester. The lightning arrester must be situated at the point where the communication line enters the building.

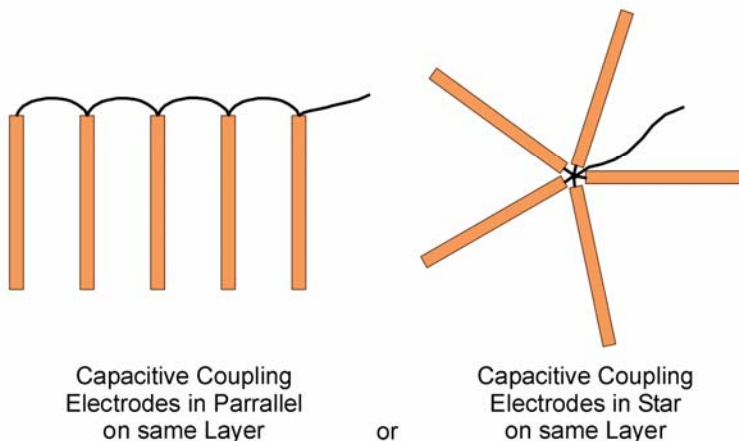
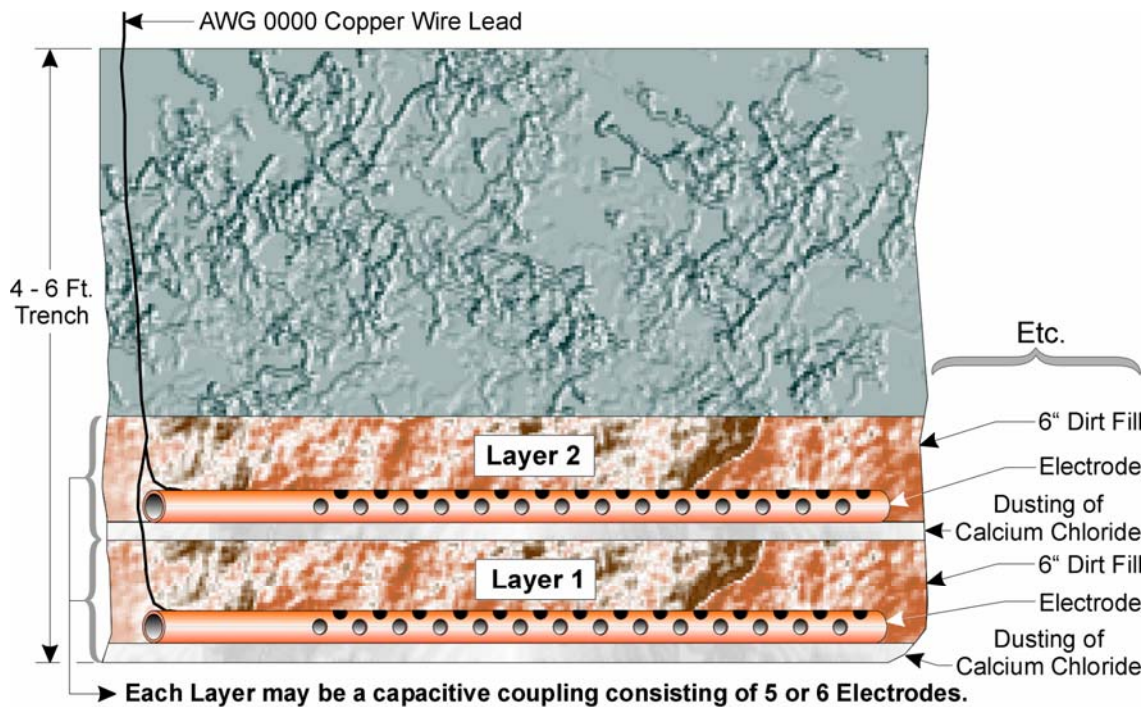

Figure 3-5 - Poor Soil Ground Bed Construction Diagram

3.3.2 Ground Wire Considerations

ControlWave, ControlWave MICRO, ControlWave EFM/GFC/XFC, ControlWaveRED, ControlWave REDIO & ControlWave I/O Expansion Rack

ControlWave Chassis are provided with a Ground Lug that accommodates up to a #4 AWG wire size. A ground wire must be run between the Chassis Ground Lug and a known good Earth Ground. The cases of the various ControlWave Modules are connected to Chassis Ground when they have been installed and secured via their two Captured Panel Fasteners. As an extra added precaution, it is recommended that a #14 AWG wire be run from PSSM Power Connector TB2-5 (Chassis Ground) (PSSM Connector TB1-3 for ControlWave MICRO unit) (SCM Connector TB1-3 for ControlWave EFM) to the same known good Earth Ground.

ControlWaveLP Process Automation Controller

A #14 AWG ground wire must be run from the ControlWaveLP's PSSB Terminal TB2-3 (Chassis Ground) to a known good Earth Ground. In lieu of a direct connection to Earth

Ground, it is recommended that the unit's Chassis Ground Terminal be connected to a conductive mounting panel or plate, a user supplied Ground Lug or a user supplied Ground Bus. The panel, lug or bus in turn must be connected to a known good Earth Ground via a #4 AWG wire.

General Considerations

The following considerations are provided for the installation of **ControlWave** system grounds:

- Size of ground wire (running to Earth Ground should be #4 AWG. It is recommended that stranded copper wire is used for this application and that the length should be as short as possible.
- This ground wire should be clamped or brazed to the Ground Bed Conductor (that is typically a stranded copper AWG 0000 cable installed vertically or horizontally).
- The wire ends should be tinned with solder prior to installation.
- The ground wire should be run such that any routing bend in the cable has a minimum radius of 12-inches below ground and 8-inches above ground.

The units Earth Ground Cable should be clamped to an exposed Ground Rod or to an AWG 0000 stranded copper Ground Cable that in turn should be connected to either an Earth Ground Rod or Earth Ground Bed. Both ends of the units Earth Ground Cable must be free of any coating such as paint or insulated covering as well as any oxidation. The connecting point of the Ground Rod or AWG 0000 Ground Cable must also be free of any coating and free of oxidation. Once the ground connection has been established (at either the Ground Rod or Ground Cable) it should be covered or coated to protect it from the environment.

3.3.3 Other Grounding Considerations

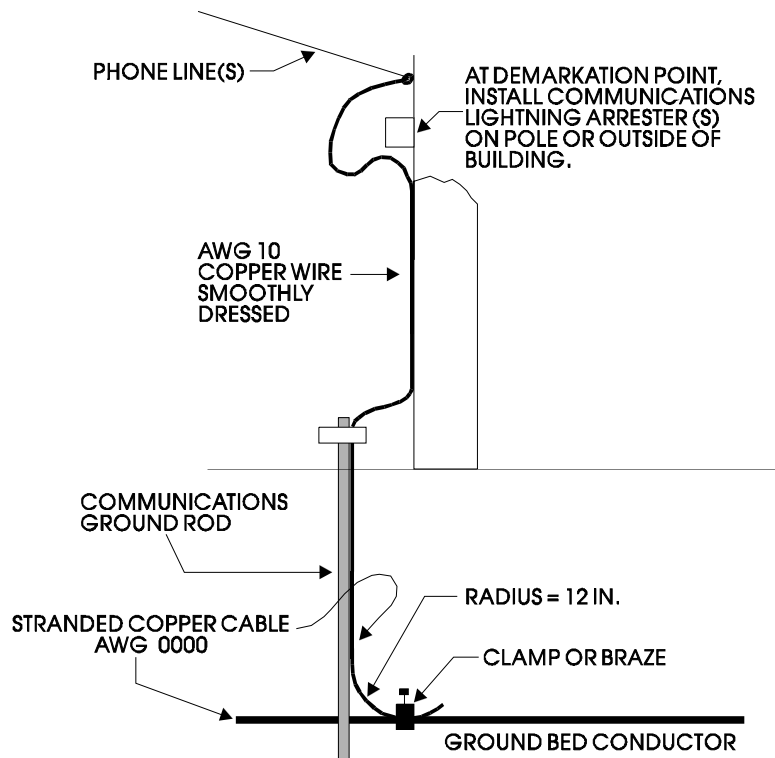

Figure 3-6 - Grounding of Phone Line

For applications employing equipment that communicates over telephone lines, a lightning arrester **Must Be** provided. For indoor equipment the lightning arrester must be installed at the point where the communication line enters the building as shown in Figure 3-6. The ground terminal of this arrester must connect to a ground rod and/or a buried ground bed.

Gas lines also require special grounding considerations. If a gas meter run includes a thermocouple or RTD sensor installed in a thermowell, the well (not the sensor) must be connected to a gas discharge-type lightning arrester as shown in Figure 3-7. A copper braid, brazed to the thermal well, is dressed into a smooth curve and connected to the arrester as shown. The curve is necessary to minimize arcing caused by lightning strikes or high static surges. The path from the lightning arrester to the ground bed should also be smooth and free from sharp bends for the same reason.

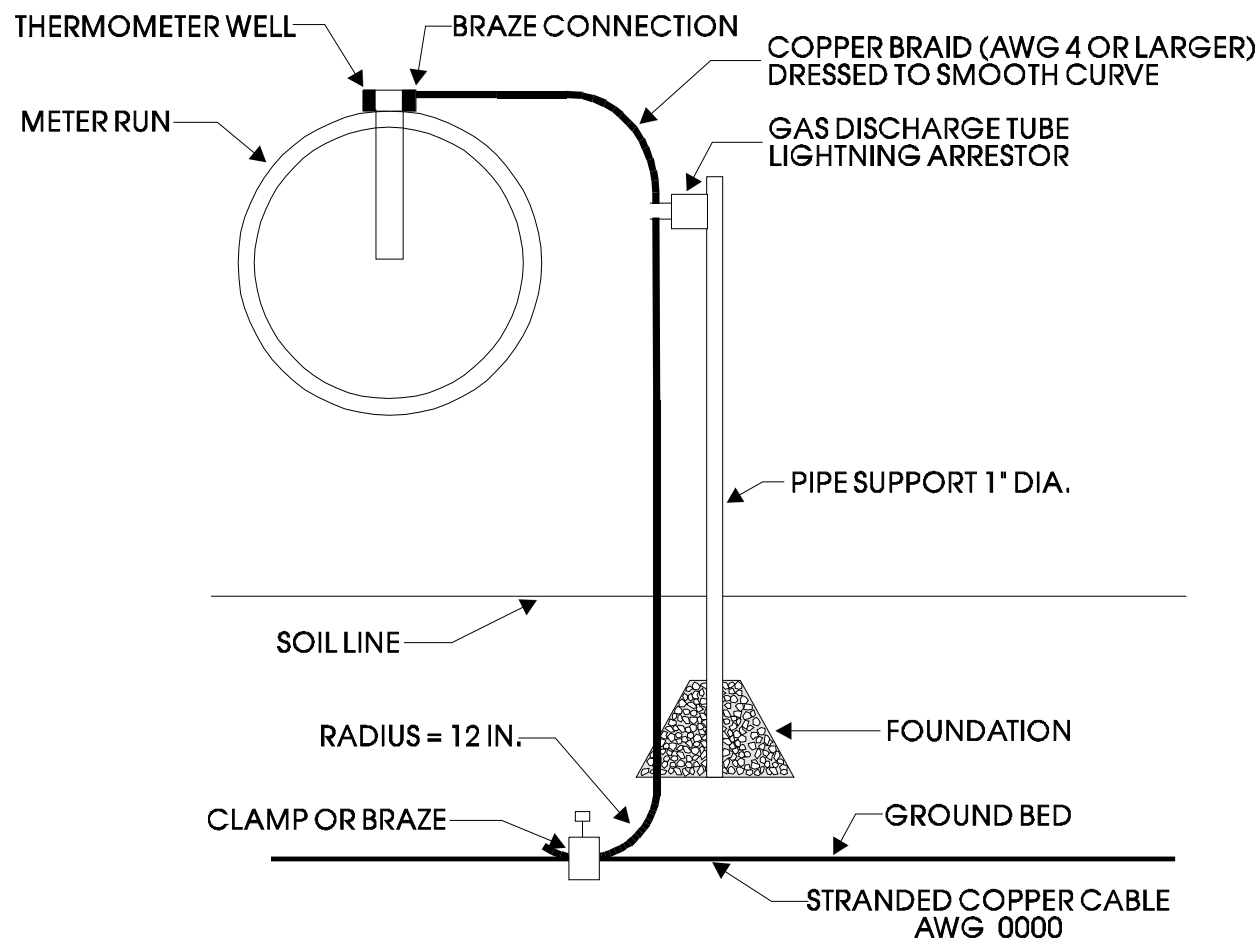

Figure 3-7 - Grounding of Thermometer Well in Gas Line

3.4 ISOLATING EQUIPMENT FROM THE PIPELINE

3.4.1 Meter Runs Without Cathodic Protection

ControlWave EFM/GFC/XFC's may be mounted directly on the pipeline or remotely on a vertical stand-alone two-inch pipe (see Figure 3-8). The Earth Ground Cable is to run between the **ControlWave EFM/GFC/XFC's** Ground Lug and Earth Ground (Rod or Bed) even though the **ControlWave EFM/GFC/XFC's** Multivariable Transducer may be

grounded to the pipeline. If any pressure transmitters or pulse transducers are remotely mounted, connect their chassis grounds to the pipeline or earth ground.

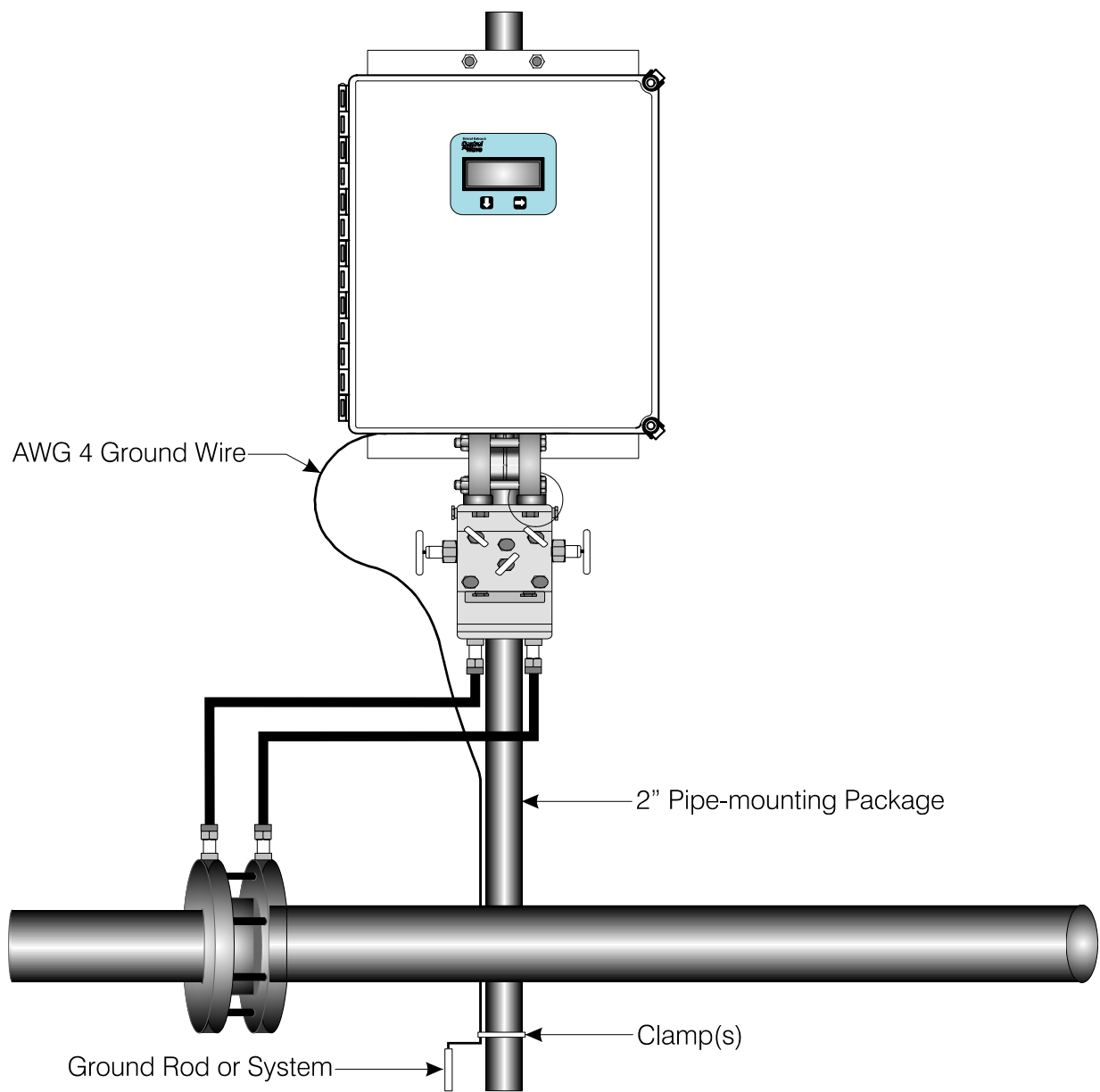

**Figure 3-8 - ControlWave EFM (Installation is similar to GFC/XFC)
Remote Installation without Cathodic Protection**

3.4.2 Meter Runs With Cathodic Protection

Dielectric isolators are available from Bristol Babcock and are always recommended as an *added measure* in isolating the **ControlWave EFM/GFC/XFC** from the pipeline even though the **ControlWave EFM/GFC/XFC** does provide 500V galvanic isolation from the pipeline and should not be affected by cathodic protection or other EMF on the pipeline. **ControlWave EFM/GFC/XFC** may be mounted directly on the pipeline (see Figure 3-9) or remotely on a vertical stand-alone two-inch stand-pipe (see Figure 3-10). It is recommended that isolation fitting always be used in remotely mounted meter systems. An isolation fittings or gasket should be installed between the following connections:

- all conductive tubing that runs between the pipeline and mounting valve manifold and/or the units multivariable pressure transducer
- all conductive connections or tubing runs between the **ControlWave EFM/GFC** and turbine meter, pulse transducer, or any input other device that is mounted on the pipeline
- any Temperature Transducer, Pressure Transmitter, etc. and their mount/interface to the pipeline

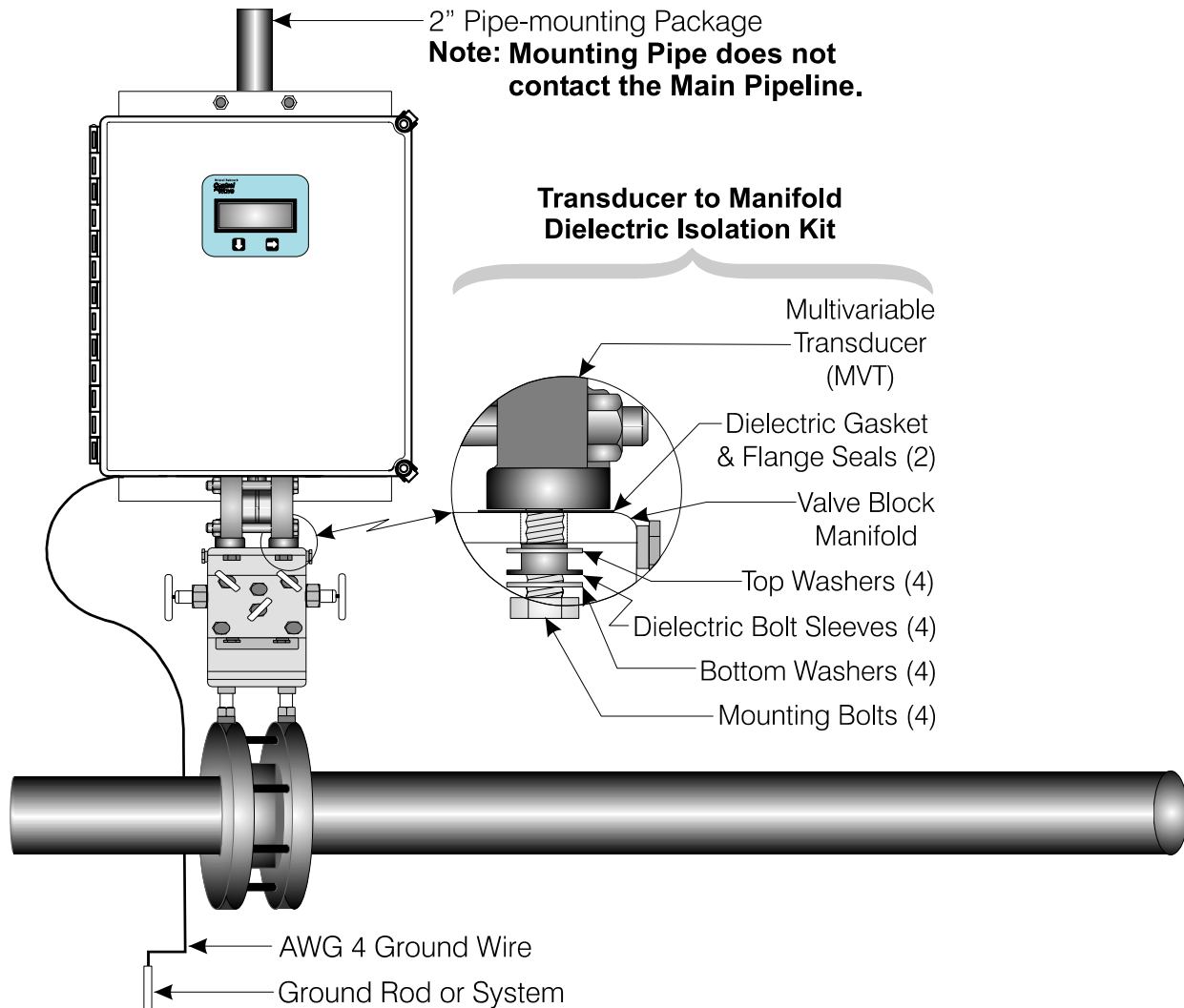

Figure 3-9 - ControlWave EFM (Installation is similar to EFM/GFC/XFC) Direct Mount Installation (with Cathodic Protection)

The ground conductor connects between the **ControlWave EFM/GFC/XFC's** Ground Lug and a known good earth ground. Connect the cases of Temperature Transducers, Pressure Transmitters, etc., to the known good earth ground. If the mounting 2-inch pipe is in continuity with the pipeline it will have to be electrically isolated from the **ControlWave EFM/GFC/XFC**. Use a strong heat-shrink material such as RAYCHEM WCSM 68/22 EU 3140. This black tubing will easily slip over the 2-inch pipe and then after uniform heating (e.g., with a rose-bud torch) it electrically insulates and increases the strength of the pipe stand.

See BBI Specification Summary F1670SS-0a for information on PGI Direct Mount Systems and Manifolds.

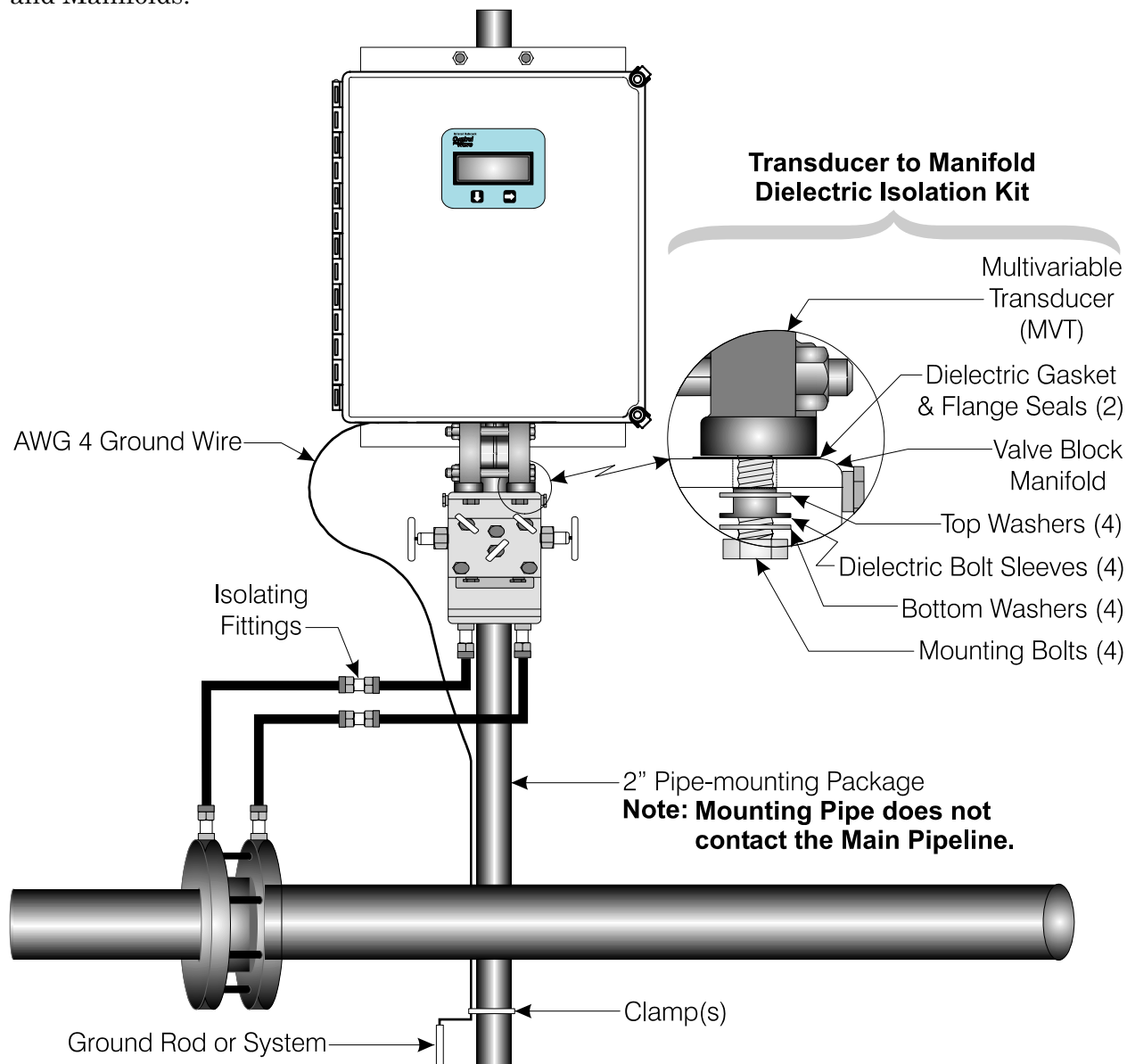

Figure 3-10 – ControlWave EFM (Installation is similar to GFC/XFC) Remote Installation (with Cathodic Protection)

Section 4 - Lightning Arresters & Surge Protectors

4.1 STROKES & STRIKES

Lightning takes the form of a pulse that typically has a 2 μ S rise and a 10 μ S to 40 μ S decay to a 50% level. The IEEE standard is an 8 μ S by 20 μ S waveform. The peak current will average 18 KA for the first impulse and about half of that for the second and third impulses. Three strokes (impulses) is the average per lightning strike. The number of visible flashes that may be seen is not necessarily the number of electrical strokes.

A lightning strike acts like a constant current source. Once ionization occurs, the air becomes a luminous conductive plasma reaching up to 60,000° F. The resistance of a struck object is of little consequence except for the power dissipation on the object ($I^2 \times R$). Fifty percent of all lightning strikes will have a first impulse of at least 18 KA, ten percent will exceed the 60 KA level, and only about one percent will exceed 120 KA.

4.1.1 Chance of Being Struck by Lightning

The map of Figure 4-1 shows the average annual number of thunderstorm days (Isokeraunic level) for the various regions within the continental U.S.A. This map is not representative of the severity of the storm or the number of lightning strikes since it does not take into account more than one lightning strike in a thunderstorm day. The Isokeraunic or Isoceraunic number provides a meteorological indication of the frequency of thunderstorm activity; the higher the Isokeraunic number the greater the lightning strike activity for a given area. These levels vary across the world from a low of 1 to a high of 300. Within the United States the Isokeraunic level varies from a low of 1 to a high of 100.

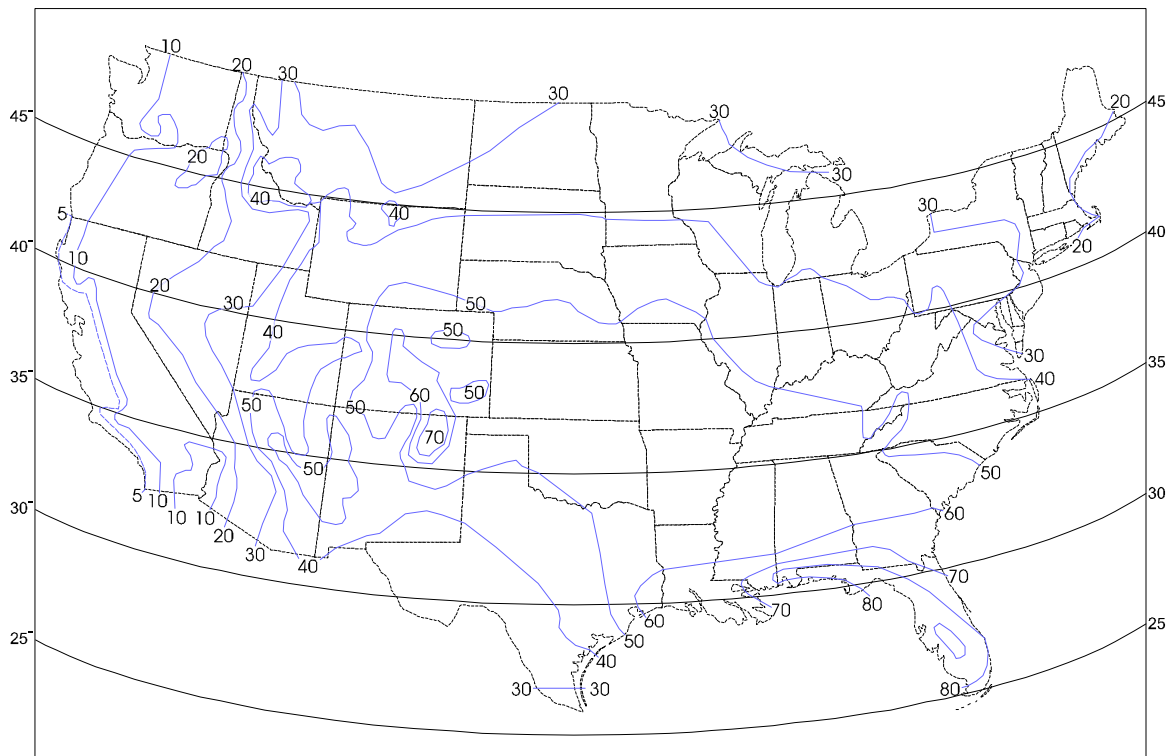

Figure 4-1 - Average Thunderstorm Days of the Year (for Continental USA)

Thunderstorms are cloud formations that produce lightning strikes (or strokes). Across the United States there is an average of 30 thunderstorm days per year. Any given storm may produce from one to several strokes. Data on the subject indicates that for an average area within the United States there can be eight to eleven strokes to each square mile per year. The risk of stroke activity is increased for various areas such central Florida where up to 38 strokes to each square mile per year are likely to occur.

To determine the probability of a given structure (tower, building, etc.) (within your location) being struck, perform the following computation:

1. Using the map of Figure 4-1 (or a comparable meteorological map for your local), find the Isokeraunic level (I) for your area. Then using Chart 1, find "A" for your area.
2. Refer to Figure 4-1 to find the latitude. Then using Chart 2, find "B" for your latitude (Lat.°).
3. Multiply "A" x "B" to get "C".
4. To calculate the number of lightning strikes per year that are likely to strike a given object (tower, mast, etc.), use the equation that follows (where "C" was calculated in step 3 and "H" is equal to the height of the object).

$$\text{Strikes Per Year} = (\text{"C"} \times H^2) \div (.57 \times 10^6)$$

Chart 1		Chart 2	
I	"A"	LAT.°	"B"
5	8	25	.170
10	26	30	.200
20	85	35	.236
30	169	40	.280
40	275	45	.325
50	402		
60	548		
70	712		
80	893		
90	1069		
100	1306		

Note for these charts:

- I = Thunderstorm Days Per Year (Isokeraunic Number)
- A = Stroke activity for associated Isokeraunic Area
- B = Height/Stroke coefficient for associated latitude

For Example: On Long Island, New York (Isokeraunic number 20), Chart 1 gives "A" to equal 85. The latitude is approximately 40°. Referring to Chart 2, "B" is found to be equal to .28. "C" for this example is equal to 23.80. Using the equation for strikes per year, it is determined that a 100-foot tower has .4 chances per year of being struck by lightning. Assuming that no other structures are nearby, the tower will more than likely be struck by lightning at least once in three years.

Note: The Isokeraunic activity numbers connoted as I, "A" and "B" in Charts 1 and 2 above are provided for the continental United States. Isokeraunic data for various countries is available from various federal or state Civil Engineering or Meterorelogical organizations. This information is typically available from manufacturers of lightning strike protection equipment (such as Lightning Arresters).

Since **ControlWave**, **ControlWave MICRO**, **ControlWave EFM/GFC/XFC**, **ControlWaveLP** and **ControlWaveEXP** units are dc operated systems that are isolated from AC grids, they are typically immune to lightning strikes to power lines or power equipment (except for inductive flashover due to close installation proximity). However, once a radio or

modem has been interfaced to a **ControlWave**, **ControlWave MICRO**, **ControlWave EFM/GFC/XFC**, **ControlWaveLP**, or **ControlWaveEXP** the possibility of damage due to a lightning strike on power or telephone lines or to a radio antenna or the antenna's tower must be considered. It is recommended that the additional lightning protection considerations listed below be followed for units installed in areas with a high possibility or history of stroke activity.

Units interfaced to a modem: In series with the phone line (as far away as possible from the equipment) - for indoor installations the lightning arrester should typically be located at the point where the line enters the structure.

Units interfaced to a radio: Mount antenna discharge unit (lightning arrester) as close as possible to where the lead in wire enters the structure. See Antenna Caution below.

4.1.2 Antenna Caution

Each year hundreds of people are killed, mutilated, or receive severe permanent injuries when attempting to install or remove an antenna or antenna lead. In many cases, the victim was aware of the danger of electrocution but failed to take adequate steps to avoid the hazard. For your safety, and for proper installation maintenance, please **read** and **follow** the safety precautions that follow - **they may save your life**.

- When installing or servicing an antenna:
DO NOT use a metal ladder. DO NOT step onto or touch an antenna mast while power is applied to an associated radio unless the radio is a low power (low current) type.
DO NOT work on a wet or windy day, especially during a thunderstorm or when there is lightning or thunder in your area. Dress properly; shoes with rubber soles and heels, rubber gloves, long sleeve shirt or jacket.
- The safe distance from power lines should be at least twice the height of the antenna and mast combination.
- Antenna Grounding per National Electrical Code Instructions:
 - A. Use AWG 10 or 8 aluminum or AWG 1 copper-clad steel or bronze wire, or larger as ground wires for both the mast and lead-in. Securely clamp the wire to the bottom of the mast.
 - B. Secure lead-in wire from antenna to antenna discharge (lightning arrester) unit and the mast ground wire to the structure (building, shed, etc.) with stand-off insulators spaced from 4 feet (1.22 meters) to 6 feet (1.83 meters) apart.
 - C. Mount antenna discharge unit as close as possible to where the lead-in wire enters the structure.
 - D. The hole drilled through the wall for the lead-in wire should be just large enough to accommodate the cable. Before drilling this hole, make sure there are no wires or pipes, etc. in the wall.
 - E. Push the cable through the hole and form a rain drip loop close to where the wire enters the exterior of the structure.
 - F. Caulk around the lead-in wire (where it enters the structure) to keep out drafts.
 - G. Install lightning arresters (antenna discharge units). The grounding conductor should be run in as straight a line as practicable from the antenna mast and/or the antenna discharge units to grounding electrode(s).
 - H. Only connect the antenna cable to the radio after the mast has been properly grounded and the lead-in cable has been properly connected to lightning arresters which in turn have each been properly connected to a known good earth ground.

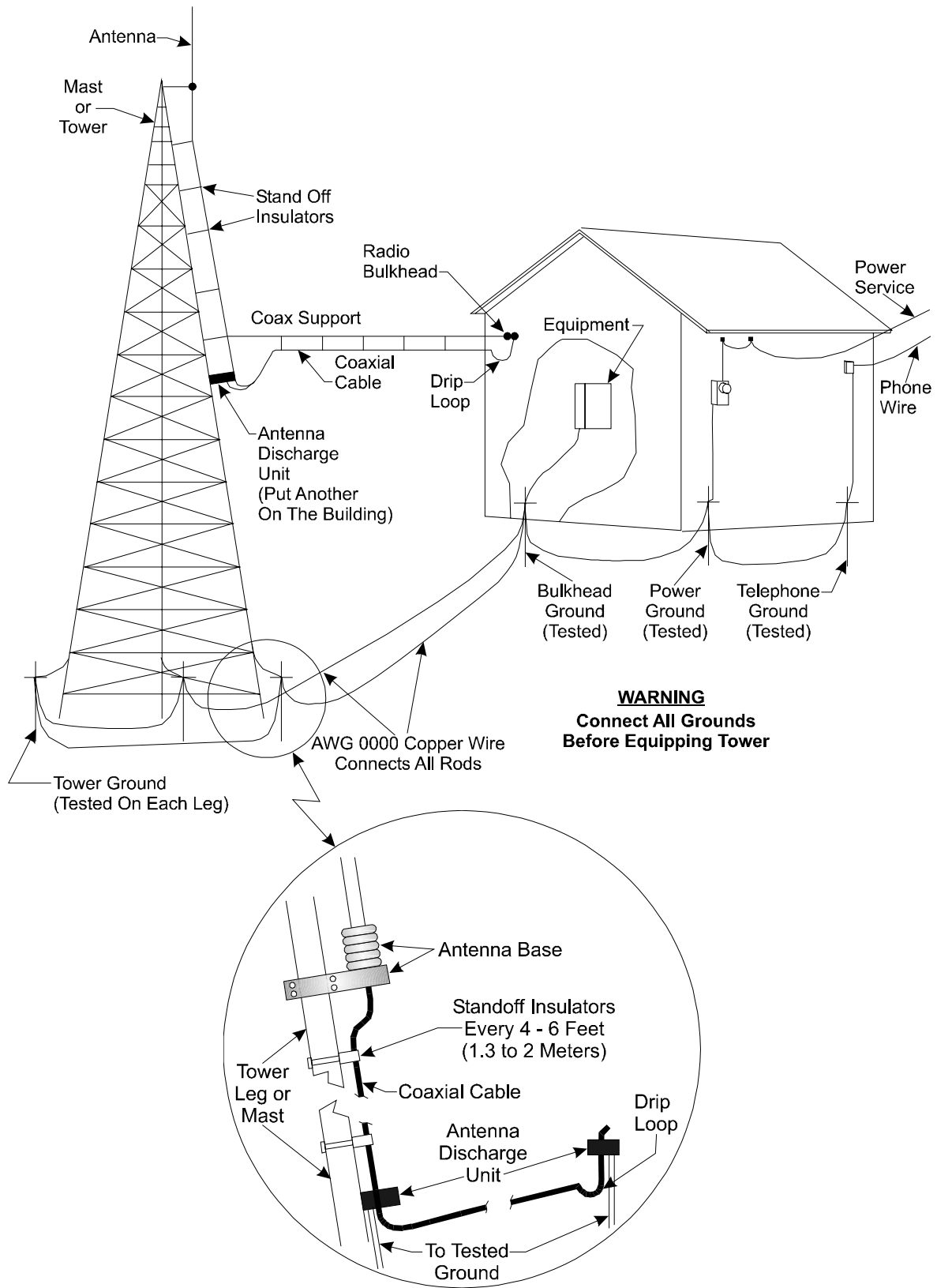

Figure 4-2 - Radio Antenna Field Installation Site Grounding Diagram

For all systems it is best to have all communication equipment input/output grounds tied together. In the case of **ControlWave** units, this is accomplished via the unit's Chassis Ground (Typically at a ground lug, ground bus or ground plate). However additional

communication equipment lightning arresters and surge suppressors should be tied to the same system ground. System ground consists of the tower leg grounds utility ground and bulkhead-equipment ground-stakes that are tied together via bare copper wire.

4.1.3 Ground Propagation

As in any medium, a dynamic pulse, like R.F., will take time to propagate. This propagation time will cause a differential step voltage to exist in time between any two ground rods that are of different radial distances from the strike. With a ground rod tied to a struck tower, the impulse will propagate its step voltage outwardly from this rod in ever-expanding circles, like a pebble thrown into a pond. If the equipment house has a separate ground rod and the power company and/or telephone company grounds are also separate, the dynamic step voltage will cause currents to flow to equalize these separate ground voltages. Then if the coax cable (associated with a radio) is the only path linking the equipment chassis with the tower ground, the surge can destroy circuitry.

4.1.4 Tying it all Together

To prevent this disaster from occurring, a grounding system must be formed which interconnects all grounds together. This will equalize and distribute the surge charge to all grounds, and at the same time, it will make for a lower surge impedance ground system. This interconnection can be done as a grid, where each ground has a separate line to each other ground, or by using a “rat Race” ring which forms a closed loop (not necessarily a perfect circle) which surrounds the equipment house completely.

By making this interconnection, it will be necessary to use proper I/O protectors for the equipment. Of course, these should be a requirement regardless of whether this grounding technique is used. I/O protectors are used for power lines (even those these don't feed into a **ControlWave** unit), telephone lines, and also to minimize EMI pick-up from a strike. Ideally it is best to place all I/O protectors on a common panel that has a low inductance path to the ground system. The **ControlWave** units would then have a single ground point from its Chassis Ground Terminal/Ground Lug to this panel. In lieu of this, the **ControlWave** unit in question should be tied to a ground rod that in turn is connected to the Earth/System Ground created for the site.

Your protected equipment connected to a common single ground system, will now be just like a bird sitting on a high tension wire. When lightning strikes, even with a 50 ohm surge impedance ground system, the entire system consisting of equipment, ground system, building, etc., will all rise together to the one million volt peak level (for example) and will all decay back down together. So long as there is no voltage differential (taken care of by protectors and ground interconnections, there will be no current flow through the equipment and therefore no resulting equipment damage.

4.1.5 Impulse Protection Summary

- Use more than one ground rod.
- Place multi-ground stakes more than their length apart.
- Tie Power, Telco, Tower, Bulkhead and equipment ground together.
- Make all ground interconnect runs that are above ground with minimum radius bends of eight inches and run them away from other conductors and use large solid wire or a solid strap.

- Watch out for dissimilar metals connections and coat accordingly.
- Use bare wire radials together where possible with ground stakes to reduce ground system impedance.
- Use I/O protectors (Phone line, Radio) with a low inductance path to the ground system.
- Ground the Coaxial Cable Shield (or use an impulse suppressor) at the bottom of the tower just above the tower leg ground connection.

4.2 USE OF LIGHTNING ARRESTERS & SURGE PROTECTORS

Units equipped with radios or modems use lightning arresters and surge protectors to protect equipment from lightning strikes, power surges and from damaging currents that have been induced onto communication lines.

The first line of defense is the Lightning Arrester. These devices typically use gas discharge bulbs that can shunt high currents and voltages to earth ground when they fire. The high current, high voltage gas discharge bulb has a relatively slow response time and only fire when their gas has been ionized by high voltage.

The second line of defense is the Surge Protector, which is made of solid state devices, fires very quickly and conducts low voltages and currents to ground. Surge protectors are built into BBI 9600 bps modems.

Lightning Arresters are applied to circuits as follows:

- Equipment or circuits that can be exposed to lightning strikes, falling power lines, high ground currents caused by power system faults, by operational problems on electric railways, etc.
- Equipment installed in dry, windy areas, such as the Great Plains and the Southwest Desert in the United States. Wind and wind blown dust can cause high voltages (static) to appear on overhead wires, fences, and metal buildings.

Note: Lightning Arresters may explode if lightning strike is very close. Mount lightning arresters where flying parts won't cause injury to equipment or personnel.

Section 5 - Wiring Techniques

5.1 OVERVIEW

This section provides information pertaining to good wiring practices. Installation of Power and “Measurement & Control” wiring is discussed. Information on obscure problems, circulating ground and power loops, bad relays, etc. is presented. Good wire preparation and connection techniques along with problems to avoid are discussed.

5.2 INSTRUMENT WIRING

Each of the rules listed below is briefly discussed; the emphasis herein is placed on the avoidance of problems as well as equipment safety.

Rule 1 - Never utilize common returns.

Rule 2 - Use twisted shielded pairs (with overall insulation) on all Signal/Control circuits.

Rule 3 - Ground cable shields at one end only.

Rule 4 - Use known good earth grounds (Rod, Bed, System) and test them periodically.

Rule 5 - Earth connections must utilize smoothly dressed large wire.

Rule 6 - Perform all work neatly and professionally.

Rule 7 - Route high power conductors away from signal wiring according to NEC Rules.

Rule 8 - Use appropriately sized wires as required by the load.

Rule 9 - Use lightning arresters and surge protectors.

Rule 10 - Make sure all wiring connections are secure.

5.2.1 Common Returns

Use of common returns on I/O wiring is one of the most common causes of obscure and difficult to troubleshoot control signal problems. Since all wires and connections have distributed resistance, inductance and capacitance, the chances of achieving a balanced system when common returns are present is very remote. Balanced systems (or circuits) are only achieved when all currents and voltages developed in association with each of the common returns are equal. In a balanced system (or circuit) there are no noise or measurement errors introduced due to by “sneak circuits.”

The illustration of Figure 5-1 shows the difference between testing an I/O circuit that is discrete and has no sneak circuits and one that utilizes common returns. Common sense tells us that it is tough to mix up connections to a twisted shielded pair (with overall vinyl covering) to every end device. Do yourself a favor; to make start up easier, **DON'T USE COMMON RETURNS!**

Field Wired Circuit Without A Common Return

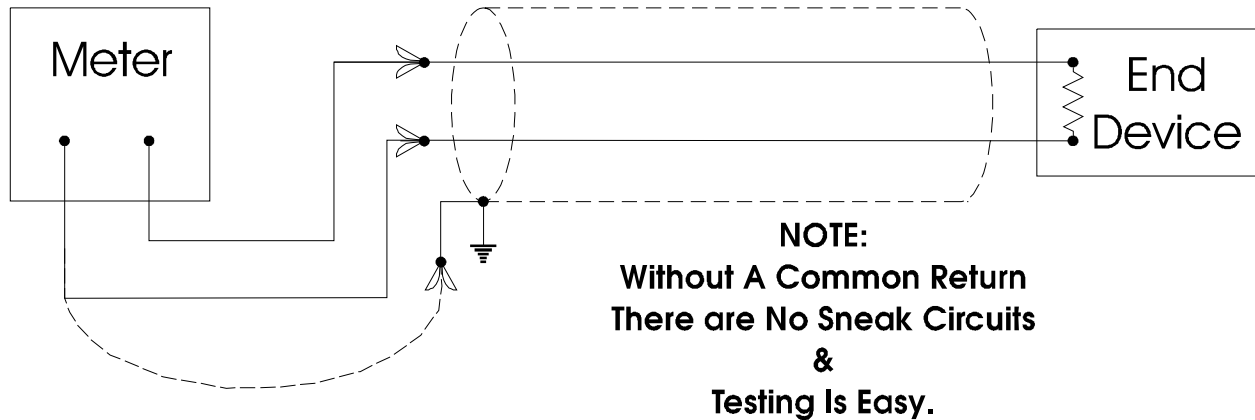

Field Wired Circuit With A Common Return

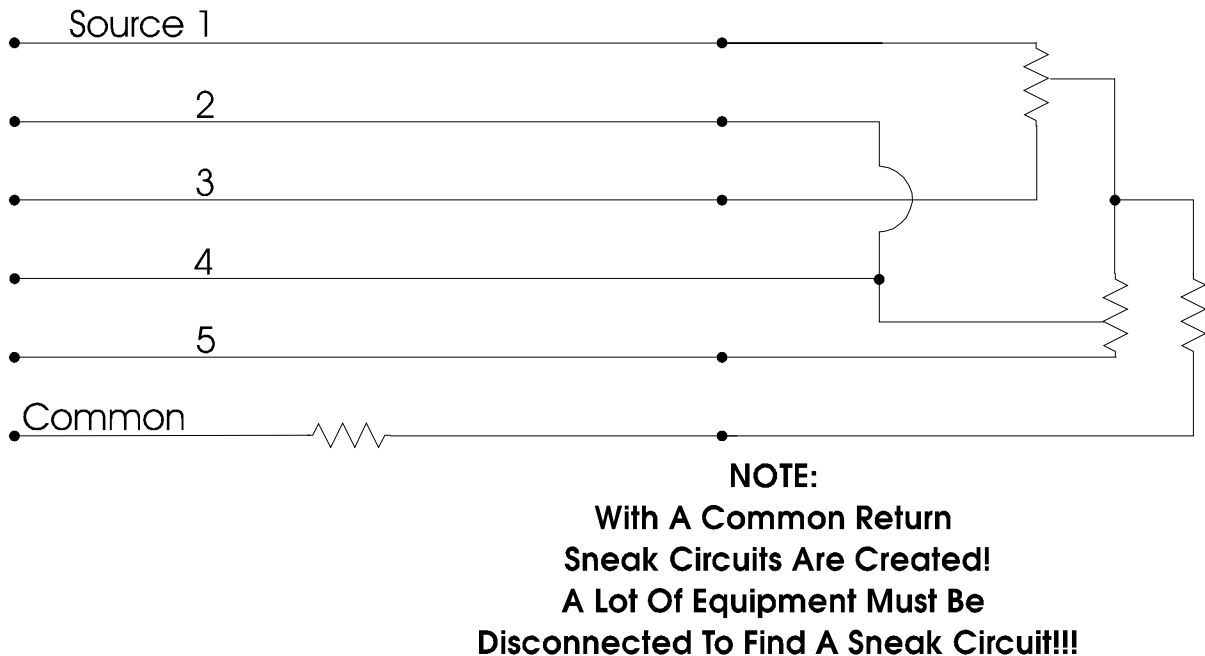

Figure 5-1 - Field Wired Circuits With & Without A Common Return

5.2.2 Use of Twisted Shielded Pair Wiring (with Overall Insulation)

For all field I/O wiring the use of twisted shielded pairs with overall insulation is highly recommended. This type of cable provides discrete insulation for each of the wires and an additional overall insulated covering that provides greater E.M.I. immunity and protection to the shield as well.

5.2.3 Grounding of Cable Shields

DO NOT connect the cable shield to more than one ground point; it should only be grounded at one end. Cable shields that are grounded at more than one point or at both ends may have a tendency to induce circulating currents or sneak circuits that raise havoc with I/O signals. This will occur when the ground systems associated with multipoint connections to a cable shield have a high resistance or impedance between them and a ground induced voltage is developed (for what ever reason, i.e., man made error or nature produced phenomena).

5.2.4 Use of Known Good Earth Grounds

ControlWave units should only have one connection to earth ground. For **ControlWave** and **ControlWave MICRO** Process Automation Controllers, **ControlWave MICRO**, **ControlWave EFM** Electronic Flow Meters, **ControlWave GFC/XFC** Gas Flow Computers and **ControlWave I/O** Expansion Racks, this connection is provided via the Ground Lug that is situated on the bottom of the unit. **ControlWaveLPs** require the installation of a ground lug, ground bus or ground plate/panel. Since **ControlWave** units are DC-based systems, grounding does not take into account AC power grounding considerations. Earth grounding the unit is absolutely necessary when the unit is equipped with a radio or modem. Additionally these units should be connected to earth ground when they are installed in areas that have frequent lightning strikes or are located near or used in conjunction with equipment that is likely to be struck by lightning or if struck by lightning may cause equipment or associated system failure. Earth Grounds must be tested and must be known to be good before connecting the **ControlWave**. Earth grounds must be periodically tested and maintained (see Section 4).

5.2.5 Earth Ground Wires

Earth connections must utilize smoothly dressed large wire. Use AWG 3 or 4 stranded copper wire with as short a length as possible. Exercise care when trimming the insulation from the wire ends. Twists the strands tightly, trim off any frizzes and tin the ends with solder. The earth ground wire should be clamped or brazed to the Ground Bed Conductor (that is typically a standard AWG 0000 copper cable. The earth ground wire should be run such that any routing bend in the cable is a minimum 8-inch radius above ground or a minimum 12-inch radius below ground.

5.2.6 Working Neatly & Professionally

Take pride in your work and observe all site and maintenance safety precautions. After properly trimming the stranded pair wire ends, twist them in the same direction as their manufacturer did and then tin them with solder. Install the tinned wire end into it's connector and then secure the associated connector's clamping screw. Remember to check these connections for tightness from time to time. If solid copper wire is used (in conjunction with the DC Power System or for Earth Ground) make sure that the conductor is not nicked when trimming off the insulation. Nicked conductors are potential disasters waiting to happen. Neatly trim shields and whenever possible, coat them to protect them and prevent shorts and water entry.

Remember loose connections, bad connections, intermittent connections, corroded connections, etc., are hard to find, waste time, create system problems and confusion in addition to being costly.

5.2.7 High Power Conductors and Signal Wiring

When routing wires, keep high power conductors away from signal conductors. Space wires appropriately to vent high voltage inductance. Refer to the National Electrical Code Handbook for regulatory and technical requirements.

5.2.8 Use of Proper Wire Size

ControlWaves utilize compression-type terminals that accommodate up to #14 AWG gauge wire. A connection is made by inserting the bared end (1/4 inch max.) into the clamp beneath the screw and securing the screw.

Allow some slack in the wires when making terminal connections. Slack makes the connections more manageable and minimizes mechanical strain on the PCB connectors. Provide external strain relief (utilizing Tie Wrap, etc.) to prevent the loose of slack at the **ControlWave**.

Be careful to use wire that is appropriately sized for the load. Refer to equipment manufacturer's Specs. and the National Electrical Code Handbook for information on wire size and wire resistance. After installing the field wiring, test each load to determine if the correct voltage or current is present at the load. If you know the resistance of the field wires (Circular Mills x Length) you should be able to calculate the load voltage. Conversely, if you know the minimum load voltage and current, you should be able to derive the maximum voltage loss that is allowable due to line resistance and then the correct wire size.

Referring to Figure 5-2, a relay that is picked by 100 mA, with a loop supply voltage of 24V and a total line resistance of 20 ohms, the load voltage (voltage across the relay) should be:

$$V_L = V_S - (V_C + V_C) \quad \text{where } V_C + V_C = (R_C + R_C) I$$

$$22 = 24 - 2 \quad \text{where } 2V = (20 \Omega) \times 0.1 A$$

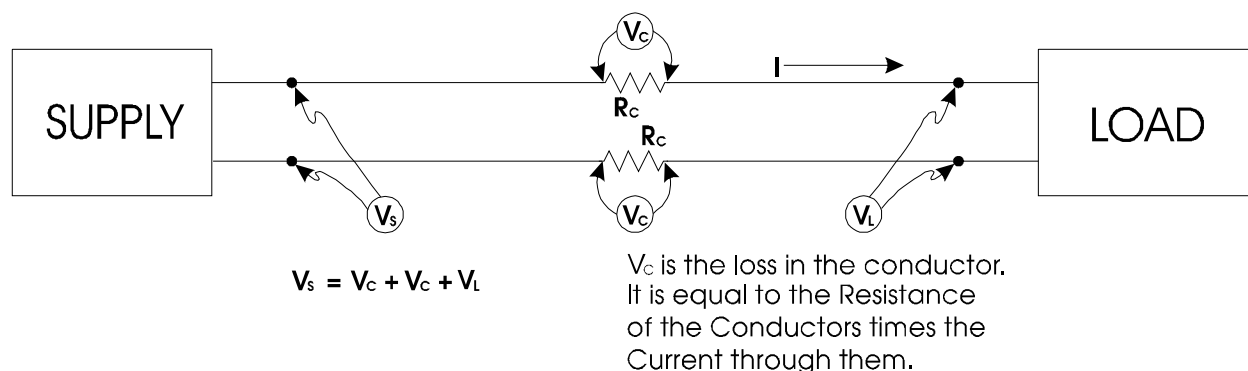

Figure 5-2 - Calculating Load Voltage due to Line Resistance

5.2.9 Lightning Arresters & Surge Protectors

Use lightning arresters in association with any radio or modem equipped unit. BBI 9600 bps modems are equipped with surge protection circuitry. Lightning arresters or Antenna

Discharge Units should be placed on the base of the antenna and at the point where the antenna lead (typically coax) enters the site equipment building. When a modem is used, a lightning arrester should be placed at the point where the phone line enters the site equipment building. If you use a modem (manufactured by other than BBI) it is recommended that you also install a surge suppressors or lightning arrester on the phone line as close to the modem as possible. *Any unit interfaced to a radio or modem must be connected to a known good earth ground.*

5.2.10 Secure Wiring Connections

Make sure that all wiring connections are secure. In time wires that were once round will become flattened due to the pressure applied by screw compression type terminals and site vibrations. After a while these compression screws have a tendency to become loose. Part of a good maintenance routine should be to check and tighten all screws associated with wiring terminal connections. Avoid nicking the wire(s) when stripping insulation. Remember, nicked conductors will lead to future problems. Also remember to provide some cabling slack and strain relief.

If installing stranded or braided wiring that has not been tinned, be sure to tightly twist the end (in the same direction as manufactured) and then trim off any frizzed wires.

READER RESPONSE FORM

Please help us make our documentation more useful to you! If you have a complaint, a suggestion, or a correction regarding this manual, please tell us by mailing this page with your comments. It's the only way we know we're doing our job by giving you correct, complete, and useful documentation.

DOCUMENT NUMBER: S1400CW

TITLE: *ControlWave™* SITE CONSIDERATIONS For EQUIPMENT INSTALLATION,
GROUNDING & WIRING

ISSUE DATE: APR., 2005

COMMENT/COMPLAINT:

Mail this page to:

Bristol Babcock Inc.

1100 Buckingham Street

Watertown, CT 06795

Attn: Technical Publications Group, Dept. 315

Bristol Babcock

PART OF THE  FKI GROUP OF COMPANIES

1100 Buckingham Street
Watertown, CT 06795
Phone: +1 (860) 945-2200
Fax: +1 (860) 945-2213
Website: www.bristolbabcock.com

U.S.A. Locations:

Northern Region

Bristol Babcock Inc.
1100 Buckingham Street
Watertown, CT 06795
Phone: +1 (860) 945-2381
Fax: +1 (860) 945-2525
NorthernUS@bristolbabcock.com

Gulf Coast Region

Bristol Babcock Inc.
2000 Governor's Circle
Suite F
Houston, TX 77092-8731
Phone: +1 (713) 685-6200
Fax: +1 (713) 681-7331
SouthwestUS@bristolbabcock.com

Western Region

Bristol Babcock Inc.
1609 South Grove Avenue
Suites 106 & 107
Ontario, CA 91761
Phone: +1 (909) 923-8488
Fax: +1 (909) 923-8988
WesternUS@bristolbabcock.com

Southeast Region

Bristol Babcock Inc.
317 S. North Lake Blvd.
Suite 1016
Altamonte Springs, FL 32701
Phone: +1 (407) 740-7084
Fax: +1 (407) 629-2106
SoutheastUS@bristolbabcock.com

Helicoid Instruments

1100 Buckingham Street
Watertown, CT 06795
Phone: +1 (860) 945-2218
Fax: +1 (860) 945-2213
jmcgrail@bristolbabcock.com

Central Region

Bristol Babcock Inc.
300 North Coit Road
Suite 1300
Richardson, TX 75080
Phone: +1 (972) 238-8935
Fax: +1 (972) 238-8198
dallas@bristolbabcock.com

Rocky Mountain Region

Bristol Babcock Inc.
906 San Juan Blvd., Suite A
Farmington, NM 87401
Phone: +1 (505) 320-5046
Fax: +1 (505) 327-3273
NewMexUS@bristolbabcock.com

Communications Technology Group

Bristol Babcock Inc.
317 S. North Lake Blvd.
Suite 1016
Altamonte Springs, FL 32701
Phone: +1 (407) 629-9464
Fax: +1 (407) 629-2106
orlandoRFgroup@bristolbabcock.com

International Affiliates:

Canada

Bristol Babcock, Canada
234 Attwell Drive
Toronto, Ont. M9W 5B3
Canada
PH: 416-675-3820
FAX: 416-674-5129
info@bristolbabcock.ca

Mexico

BBI, S.A. de C.V.
Homero No. 1343, 3er Piso
Col. Morales Polanco
11540 Mexico, D.F.
Mexico
PH: (52-55)-52-81-81-12
FAX: (52-55)-52-81-81-09
Mexico@bristolbabcock.com

United Kingdom

Bristol Babcock Ltd.
Blackpole Road
Worcester, WR3 8YB
United Kingdom
PH: +44 (0) 1905 856950
FAX: +44 (0) 1905 856969
enquiries@bristol-babcock.com

Asia Pacific

Bristol Babcock, Inc.
PO Box 1987
Bunbury, Western Australia
6231
PH: +61 (0) 8 9791 3654
FAX: +61 (0) 8 9791 3173
dtrench@bdsa.com.au

Victoria, Australia
PH: +61 (0) 3 9384 2171
FAX: +61 (0) 3 8660 2501

Calgary Office

Bristol Babcock, Canada
3812 Edmonton Trail N.E.
Calgary, Alberta T2E 5T6
Canada
PH: 403-265-4808
FAX: 403-233-2914
janetl@bristolbabcock.ca

Villahermosa Office

BBI, S.A. de C.V.
Av. Plomo No.2
Bodega No. 1 - Ciudad
Industrial
Villahermosa, Tabasco 86010
Mexico
PH: 52-993-353-3142
FAX: 52-993-353-3145
bbivsa@prodigy.net.mx

Middle East

Bristol Babcock Ltd.
Blackpole Road
Worcester, WR3 8YB
United Kingdom
PH: +44 (0) 1905 856950
FAX: +44 (0) 1905 856969
enquiries@bristol-babcock.com

CARE AND HANDLING OF PC BOARDS AND ESD-SENSITIVE **COMPONENTS**

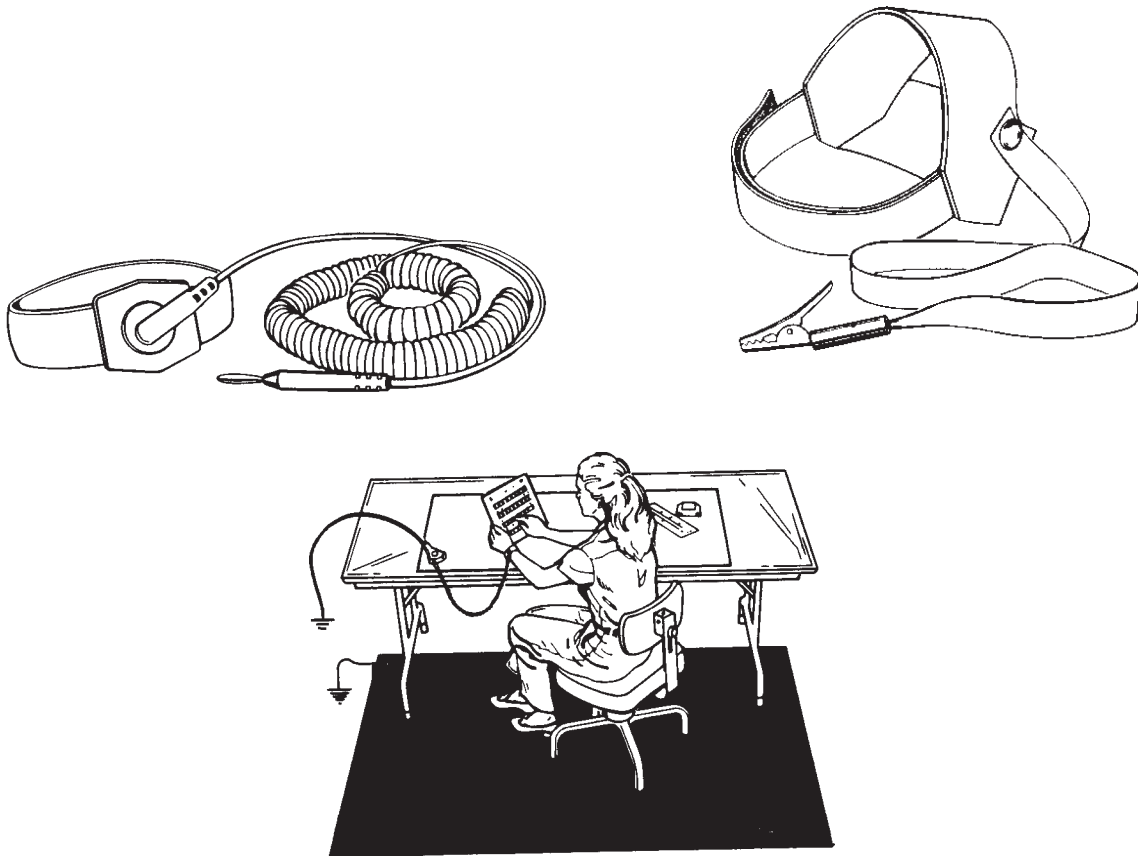

TABLE OF CONTENTS

	PAGE
TOOLS AND MATERIALS REQUIRED	1
ESD-SENSITIVE COMPONENT HANDLING PROCEDURE	2
1. Introduction	2
2. General Rules	3
3. Protecting ESD-Sensitive Components	5
4. Static-Safe Field Procedure	6
5. Cleaning and Lubricating	8
6. Completion	10

TOOLS AND MATERIALS REQUIRED

1. Tools

Anti-Static Field kit. It is recommended that an anti-static field kit be kept on any site where solid-state printed circuit boards and other ESD-sensitive components are handled. These kits are designed to remove any existing static charge and to prevent the build-up of a static charge that could damage a PC board or ESD-sensitive components. The typical anti-static field kit consists of the following components:

1. A work surface (10mm conductive plastic sheet with a female snap fastener in one corner for ground cord attachment).
2. A 15-foot long ground cord for grounding the work surface.
3. Wrist strap (available in two sizes, large and small, for proper fit and comfort) with a female snap fastener for ground cord attachment.
4. A coiled ground cord with a practical extension length of 10 feet for attachment to the wrist strap.

Toothbrush (any standard one will do)

2. Materials

- Inhibitor (Texwipe Gold Mist ; Chemtronics Gold Guard, or equivalent)
- Cleaner (Chemtronics Electro-Wash; Freon TF, or equivalent)
- Wiping cloth (Kimberly-Clark Kim Wipes, or equivalent)

ESD-SENSITIVE COMPONENT HANDLING PROCEDURE

1. Introduction

Microelectronic devices such as PC boards, chips and other components are electrostatic-sensitive. Electrostatic discharge (ESD) of as few as 110 volts can damage or disrupt the functioning of such devices. Imagine the damage possible from the 35,000 volts (or more) that you can generate on a dry winter day by simply walking across a carpet. In fact, you can generate as much as 6,000 volts just working at a bench.

There are two kinds of damage that can be caused by the static charge. The more severe kind results in complete failure of the PC board or component. This kind of damage is relatively simple, although often expensive, to remedy by replacing the affected item(s). The second kind of damage results in a degradation or weakening which does not result in an outright failure of the component. This kind of damage is difficult to detect and often results in faulty performance, intermittent failures, and service calls.

Minimize the risk of ESD-sensitive component damage by preventing static build-up and by promptly removing any existing charge. Grounding is effective, if the carrier of the static charge is **conductive** such as a human body. To protect components from **nonconductive** carriers of static charges such as plastic boxes, place the component in static-shielding bags.

This manual contains general rules to be followed while handling ESD-sensitive components. Use of the anti-static field kit to properly ground the human body as well as the work surface is also discussed.

Table 1		
Typical Electrostatic Voltages		
Electrostatic Voltages		
Means of Static Generation	10-20 Percent Relative Humidity	65-90 Percent Relative Humidity
Walking across carpet	35,000	1,500
Walking over vinyl floor	12,000	250
Worker at bench	6,000	100
Vinyl envelopes for work instructions	7,000	600
Poly bag picked up from bench	20,000	1,200
Work chair padded with poly foam	18,000	1,500

2. General Rules

- (1) ESD-sensitive components shall **only** be removed from their static-shielding bags by a person who is properly grounded.
- (2) When taken out of their static-shielding bags, ESD-sensitive components shall **never** be placed over, or on, a surface which has not been properly grounded.
- (3) ESD-sensitive components shall be handled in such a way that the body does not come in contact with the conductor paths and board components. Handle ESD-sensitive components in such a way that they will not suffer damage from physical abuse or from electric shock.
- (4) EPROMS/PROMS shall be kept in anti-static tubes until they are ready to use and shall be removed **only** by a person who is properly grounded.
- (5) When inserting and removing EPROMS/PROMS from PC boards, use a chip removal tool similar to the one shown in the figure following. Remember, all work should be performed on a properly grounded surface by a properly-grounded person.

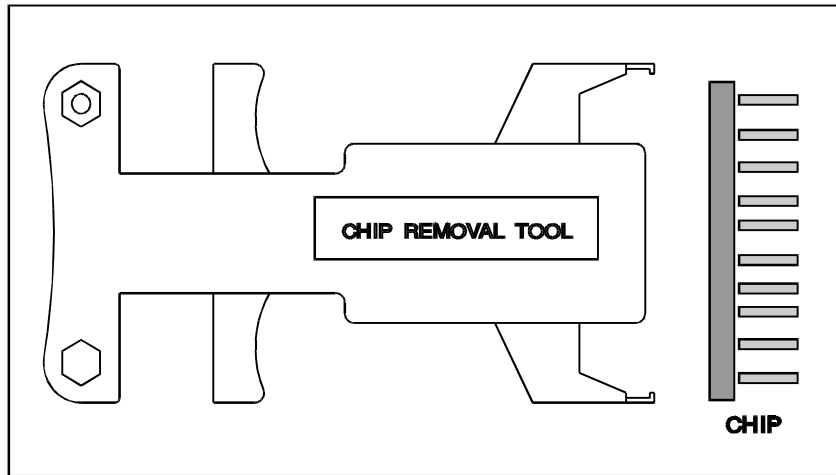

Typical Chip Removal Tool

- (6) It is important to note when inserting EPROMS/PROMS, that the index notch on the PROM must be matched with the index notch on the socket. Before pushing the chip into the socket, make sure all the pins are aligned with the respective socket-holes. Take special care not to crush any of the pins as this could destroy the chip.
- (7) Power the system down before removing or inserting comb connectors/plugs or removing and reinstalling PC boards or ESD-sensitive components from card files or mounting hardware. Follow the power-down procedure applicable to the system being serviced.
- (8) Handle all defective boards or components with the same care as new components. This helps eliminate damage caused by mishandling. Do not strip used PC boards for parts. Ship defective boards promptly to Bristol Babcock in a static-shielding bag placed *inside* static-shielding foam and a box to avoid damage during shipment.

CAUTION

Don't place ESD-sensitive components and paperwork in the same bag.

The static caused by sliding the paper into the bag could develop a charge and damage the component(s).

- (9) Include a note, which describes the malfunction, in a *separate* bag along with each component being shipped. The repair facility will service the component and promptly return it to the field.

3. Protecting ESD-Sensitive Components

- (1) As stated previously, it is recommended that an electrically-conductive anti-static field kit be kept on any site where ESD-sensitive components are handled. A recommended ESD-protective workplace arrangement is shown on page 7. The anti-static safety kit serves to protect the equipment as well as the worker. As a safety feature, a resistor (usually of the one-megohm, 1/2-watt, current-limiting type) has been installed in the molded caps of the wrist strap cord and the ground cord. This resistor limits current should a worker accidentally come in contact with a power source. Do not remove the molded caps from grounded cords. If a cord is damaged, replace it immediately.
- (2) Be sure to position the work surface so that it does **not** touch grounded conductive objects. The protective resistor is there to limit the current which can flow through the strap. When the work surface touches a grounded conductive object, a short is created which draws the current flow and defeats the purpose of the current-limiting resistor.
- (3) Check resistivity of wrist strap periodically using a commercially-available system tester similar to the one shown in the figure below:

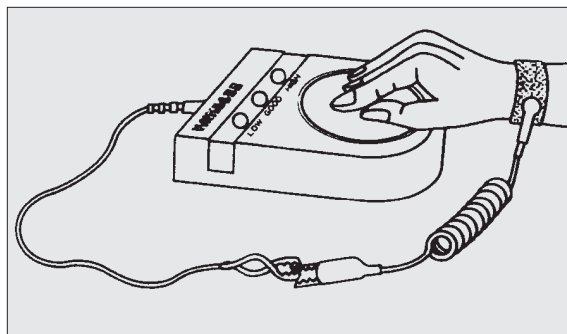

Note: If a system checker is not available, use an ohmmeter connected to the cable ends to measure its resistance. The ohmmeter reading should be **1 megohm +/- 15%**. Be sure that the calibration date of the ohmmeter has not expired. If the ohmmeter reading exceeds **1 megohm by +/- 15%**, replace the ground cord with a new one.

4. Static-safe Field Procedure

- (1) On reaching the work location, unfold and lay out the work surface on a convenient surface (table or floor). Omit this step if the table or floor has a built-in ESD-safe work surface.
- (2) Attach the ground cord to the work surface via the snap fasteners and attach the other end of the ground cord to a reliable ground using an alligator clip.
- (3) Note which boards or components are to be inserted or replaced.
- (4) Power-down the system following the recommended power-down procedure.
- (5) Slip on a known-good wristband, which should fit snugly; an extremely loose fit is not desirable.
- (6) Snap the ground cord to the wristband. Attach the other end of the ground cord to a reliable ground using the alligator clip.

- (7) The components can now be handled following the general rules as described in the instruction manual for the component.
- (8) Place the component in a static-shielding bag before the ground cord is disconnected. This assures protection from electrostatic charge in case the work surface is located beyond the reach of the extended ground cord.

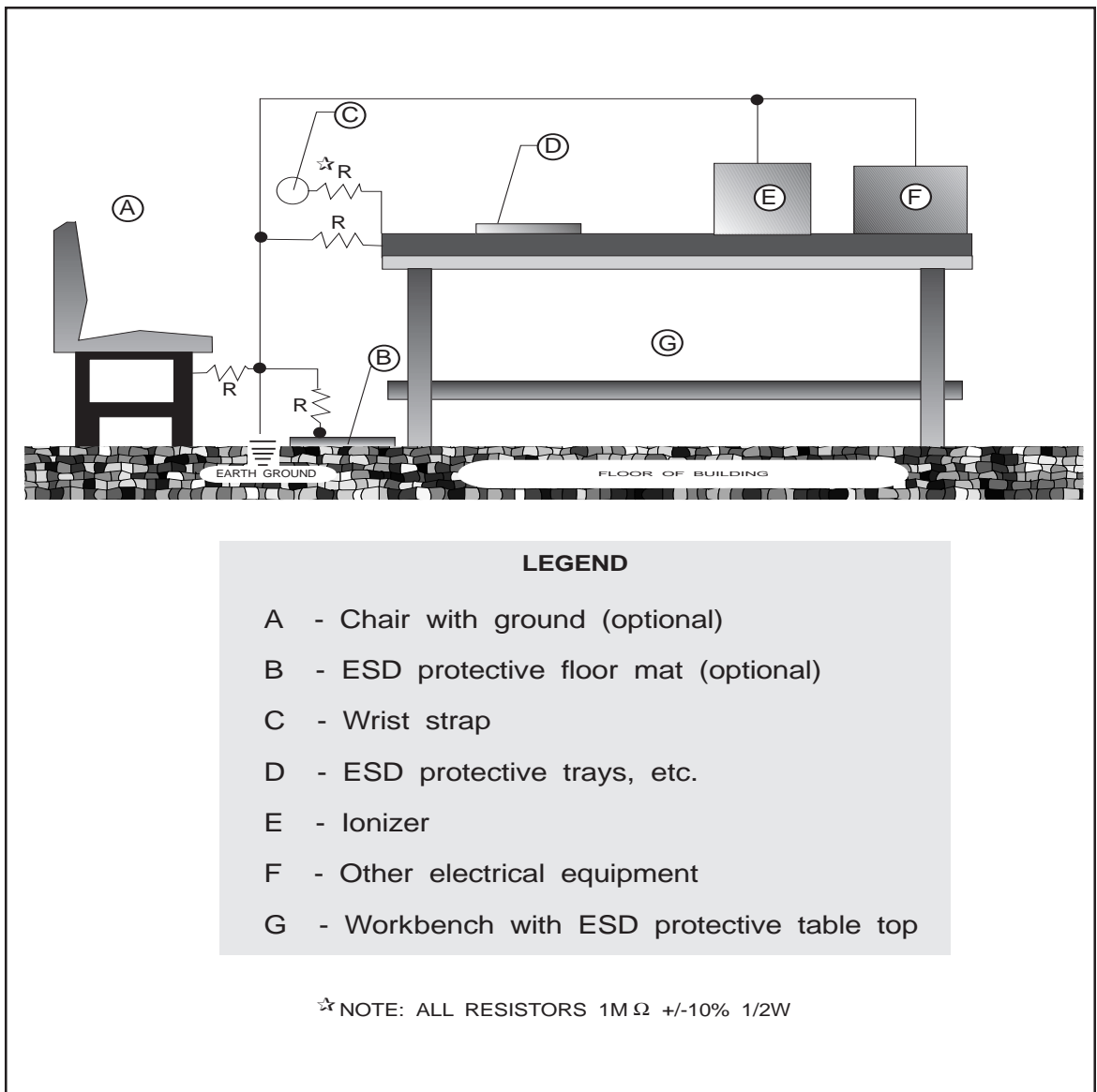

- (9) If a component is to undergo on-site testing, it may be safely placed on the grounded work surface for that purpose.
- (10) After all component work is accomplished, remove the wrist straps and ground wire and place in the pouch of the work surface for future use.

5. Cleaning And Lubricating

The following procedure should be performed periodically for all PC boards and when a PC board is being replaced.

CAUTION

Many PC board connectors are covered with a very fine gold-plate.

Do not use any abrasive cleaning substance or object such as a pencil eraser to clean connectors.

Use only the approved cleaner/lubricants specified in the procedure following.

WARNING

Aerosol cans and products are extremely combustible.

Contact with a live circuit, or extreme heat can cause an explosion.

Turn OFF all power and find an isolated, and ventilated area to use any aerosol products specified in this procedure.

- (1) Turn the main line power **OFF**. Blow or vacuum out the component. This should remove potential sources of dust or dirt contamination during the remainder of this procedure.

- (2) Clean PC board connectors as follows:
- a. Review the static-safe field procedure detailed earlier.
 - b. Following the ESD-sensitive component handling procedures, remove the connectors from the boards and remove the PC boards from their holders.
 - c. Use cleaner to remove excessive dust build-up from comb connectors and other connectors. This cleaner is especially useful for removing dust.
 - d. Liberally spray all PC board contacts with Inhibitor. The inhibitor:
 - Provides a long lasting lubricant and leaves a protective film to guard against corrosion
 - Improves performance and reliability
 - Extends the life of the contacts
 - Is nonconductive, and is safe for use on most plastics
 - e. Clean the comb contacts using a **lint-free** wiping cloth.
 - f. Lightly mist all comb contacts again with Inhibitor.
- NOTE: Do not use so much Inhibitor that it drips.**
- g. Repeat the above procedure for the other PC boards from the device.

- (3) Cleaning PC edge connectors
- a. Use cleaner to remove excessive dust build-up from connectors. This cleaner is especially useful for removing dust.
 - b. Liberally spray the outboard connector with Inhibitor.
 - c. Lightly brush the outboard connector with a soft, non-metallic, bristle brush such as a toothbrush.

- d. Spray the connector liberally to flush out any contaminants.
- e. Remove any excess spray by shaking the connector or wiping with either a toothbrush, or a **lint-free** wiping cloth.

6. Completion

- (1) Replace any parts that were removed.
- (2) Make sure that the component cover is secure.
- (3) Return the system to **normal** operation.
- (4) Check that the component operates normally.

ControlWave Redundant I/O & Comm. Switch Unit

**Emerson Process Management
Remote Automation Solutions**
1100 Buckingham Street
Watertown, CT 06795
Phone: +1 (860) 945-2262
Fax: +1 (860) 945-2525
www.EmersonProcess.com/Remote

**Emerson Process Management
Remote Automation Solutions**
6338 Viscount Rd.
Mississauga, Ont. L4V 1H3
Canada
Phone: 905-362-0880
Fax: 905-362-0882
www.EmersonProcess.com/Remote

Emerson Process Management Mexico
Viveros de la Colina No 238
Col. Viveros de la Loma
Tlalnepantla, Mexico 54080
T +52 (55) 57.28.08.00
F +52 (55) 53.66.26.18
www.EmersonProcess.com/Remote

**Emerson Process Management, Ltd.
Remote Automation Solutions**
Blackpole Road
Worcester, WR3 8YB
United Kingdom
Phone: +44 1905 856950
Fax: +44 1905 856969
www.EmersonProcess.com/Remote

**Emerson Process Management
Bristol Digital Systems Australasia**
22 Portofino Crescent,
Grand Canals Bunbury, Western Australia 6230
Mail to: PO Box 1987 (zip 6231)
Phone: +61 (8) 9725-2355
Fax: +61 (8) 8 9725-2955
www.EmersonProcess.com/Remote

NOTICE

“Remote Automation Solutions (“RAS”), division of Emerson Process Management shall not be liable for technical or editorial errors in this manual or omissions from this manual. RAS MAKES NO WARRANTIES, EXPRESSED OR IMPLIED, INCLUDING THE IMPLIED WARRANTIES OF MERCHANTABILITY AND FITNESS FOR A PARTICULAR PURPOSE WITH RESPECT TO THIS MANUAL AND, IN NO EVENT SHALL RAS BE LIABLE FOR ANY INCIDENTAL, PUNITIVE, SPECIAL OR CONSEQUENTIAL DAMAGES INCLUDING, BUT NOT LIMITED TO, LOSS OF PRODUCTION, LOSS OF PROFITS, LOSS OF REVENUE OR USE AND COSTS INCURRED INCLUDING WITHOUT LIMITATION FOR CAPITAL, FUEL AND POWER, AND CLAIMS OF THIRD PARTIES.

Bristol, Inc., Bristol Babcock Ltd, Bristol Canada, BBI SA de CV and the Flow Computer Division are wholly owned subsidiaries of Emerson Electric Co. doing business as Remote Automation Solutions (“RAS”), a division of Emerson Process Management. FloBoss, ROCLINK, Bristol, Bristol Babcock, ControlWave, TeleFlow and Helicoid are trademarks of RAS. AMS, PlantWeb and the PlantWeb logo are marks of Emerson Electric Co. The Emerson logo is a trademark and service mark of the Emerson Electric Co. All other trademarks are property of their respective owners.

The contents of this publication are presented for informational purposes only. While every effort has been made to ensure informational accuracy, they are not to be construed as warranties or guarantees, express or implied, regarding the products or services described herein or their use or applicability. RAS reserves the right to modify or improve the designs or specifications of such products at any time without notice. All sales are governed by RAS' terms and conditions which are available upon request.

© 2008 Remote Automation Solutions, division of Emerson Process Management. All rights reserved.

[Return to the Table of Contents](#)

[Return to the List of Manuals](#)