

ABB Drives

User's Manual PROFIBUS DP Adapter Module RPBA-01

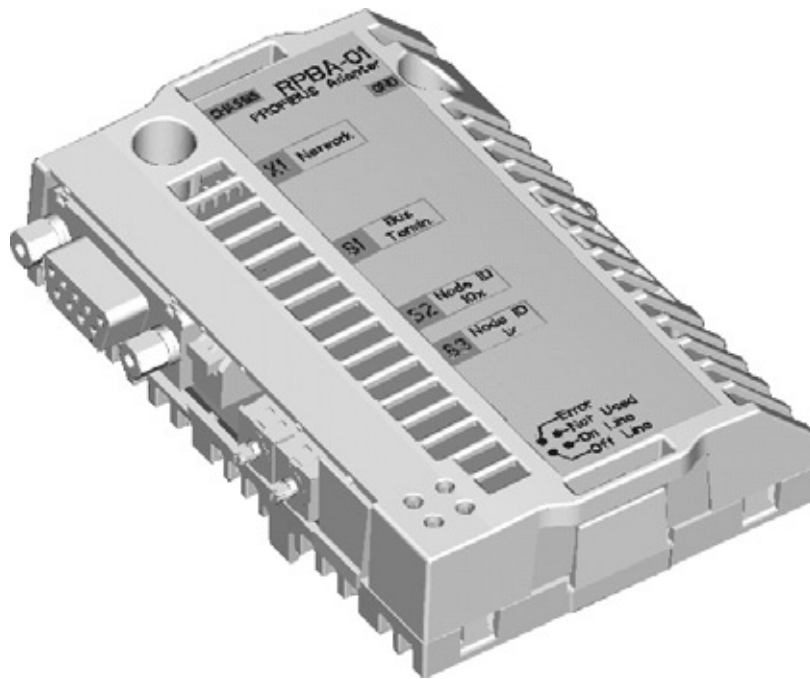

PROFIBUS DP Adapter Module
RPBA-01

User's Manual

3AFE 64504215 REV F EN

EFFECTIVE: 20.06.2005

Safety instructions

Overview

This chapter states the general safety instructions that must be followed when installing and operating the RPBA-01 PROFIBUS DP Adapter module.

The material in this chapter must be studied before attempting any work on, or with, the unit.

In addition to the safety instructions given below, read the complete safety instructions of the specific drive you are working on.

General safety instructions



WARNING! All electrical installation and maintenance work on the drive should be carried out by qualified electricians.

The drive and adjoining equipment must be properly earthed.

Do not attempt any work on a powered drive. After switching off the mains, always allow the intermediate circuit capacitors 5 minutes to discharge before working on the frequency converter, the motor or the motor cable. It is good practice to check (with a voltage indicating instrument) that the drive is in fact discharged before beginning work.

The motor cable terminals of the drive are at a dangerously high voltage when mains power is applied, regardless of motor operation.

There can be dangerous voltages inside the drive from external control circuits even when the drive mains power is shut off. Exercise appropriate care when working on the unit. Neglecting these instructions can cause physical injury or death.

Table of contents

| | |
|--|---------------|
| Safety instructions | 5 |
| Overview | 5 |
| General safety instructions | 5 |
| Table of contents | 7 |
| Introduction | 11 |
| Intended audience | 11 |
| Before you start | 11 |
| What this manual contains | 11 |
| Terms used in this manual | 13 |
| Further information | 13 |
| Overview | 15 |
| Overview | 15 |
| PROFIBUS standard | 15 |
| The RPBA-01 PROFIBUS DP Adapter module | 16 |
| Compatibility | 17 |
| Delivery check | 17 |
| Warranty and liability information | 18 |
| Quick start-up guide | 19 |
| Overview | 19 |
| PLC configuration | 19 |
| Mechanical and electrical installation | 21 |
| Drive configuration | 21 |
| Parameter setting examples | 23 |

| | |
|---|-----------|
| Mechanical installation | 27 |
| Mounting | 27 |
| Electrical installation | 29 |
| Overview | 29 |
| General cabling instructions | 29 |
| Bus termination | 29 |
| Node selection | 30 |
| PROFIBUS connection | 31 |
| Programming | 33 |
| Overview | 33 |
| Configuring the system | 33 |
| PROFIBUS connection configuration | 33 |
| Control locations | 37 |
| DP-V0 communication | 39 |
| Overview | 39 |
| PROFIBUS DP | 39 |
| Service Access Points | 39 |
| Communication start-up | 40 |
| PPO message types | 45 |
| The Control Word and the Status Word | 46 |
| References | 46 |
| Actual Values | 46 |
| Parameter handling in cyclic communication (DP) | 51 |
| DP-V1 communication | 63 |
| Overview | 63 |
| PROFIBUS DP | 63 |
| Service Access Points | 63 |
| Communication start-up | 64 |
| PPO message types | 71 |
| The Control Word and the Status Word | 72 |

- References 72
- Actual Values 72
- DP-V1 read/write request sequence 78
- Parameter data transfer examples 88

- Fault tracing* 99**
- LED indications 99

- PROFIdrive parameters* 101**

- Definitions and abbreviations* 107**
- PROFIBUS definitions 107
- PROFIBUS abbreviations 109

- Technical data* 111**
- RPBA-01 111
- PROFIBUS link 113

Introduction

Intended audience

The manual is intended for the people who are responsible for commissioning and using an RPBA-01 PROFIBUS DP Adapter module. The reader is expected to have a basic knowledge of electrical fundamentals, electrical wiring practices and how to operate the drive.

Before you start

It is assumed that the drive is installed and ready to operate before starting the installation of the extension module.

In addition to conventional installation tools, have the drive manuals available during the installation as they contain important information not included in this manual. The drive manuals are referred to at various points of this document.

What this manual contains

This manual contains information on the wiring, configuration and use of the RPBA-01 PROFIBUS DP Adapter module.

Safety instructions are featured in the first few pages of this manual.

Overview contains a short description of the PROFIBUS protocol and the RPBA-01 PROFIBUS DP Adapter module, a delivery checklist, and information on the manufacturer's warranty.

Quick start-up guide contains a short description of how to set up the RPBA-01 PROFIBUS DP Adapter module.

Mechanical installation contains placing and mounting instructions for the module.

Electrical installation contains wiring, bus termination and earthing instructions.

Programming explains how to program the master station and the drive before the communication through the adapter module can be started.

DP-V0 communication contains a description of how data is transmitted through the RPBA-01 module using the PROFIBUS-DP (DP-V0) protocol.

DP-V1 communication contains a description of how data is transmitted through the RPBA-01 module using the DP-V1 extension of the PROFIBUS DP protocol.

Fault tracing explains how to trace faults with the status LEDs on the RPBA-01 module.

PROFIBUS parameters presents the PROFIBUS Profile-specific parameters.

Definitions and abbreviations explains definitions and abbreviations concerning the PROFIBUS protocol family.

Technical data contains information on physical dimensions, configurable settings and connectors of the module and the specification of the PROFIBUS link.

Terms used in this manual

Communication Module

Communication Module is a name for a device (e.g. a fieldbus adapter) through which the drive is connected to an external communication network (e.g. a fieldbus). The communication with the module is activated with a drive parameter.

Data Sets and Data Words

Each data set consists of three 16-bit words, ie. data words. The Control Word (sometimes called the Command Word) and the Status Word, References and Actual Values (see the chapters *DP-V0 communication* and *DP-V1 communication*) are types of data words; the contents of some data words are user-definable.

RPBA-01 PROFIBUS DP Adapter module

The RPBA-01 PROFIBUS DP Adapter module is one of the optional fieldbus adapter modules available for ABB drives. The RPBA-01 is a device through which an ABB drive is connected to a PROFIBUS network.

Parameter

A parameter is an operating instruction for the drive. Parameters can be read and programmed with the drive control panel, or through the RPBA-01 module.

Further information

Further information is available on the World Wide Web from **www.profibus.com**.

Overview

Overview

This chapter contains a short description of the PROFIBUS standard and the RPBA-01 PROFIBUS DP Adapter module, a delivery checklist and warranty information.

PROFIBUS standard

PROFIBUS is an open serial communication standard that enables data exchange between all kinds of automation components. There are three main variations of PROFIBUS: PROFIBUS-FMS (Fieldbus Message Specification), PROFIBUS-DP (Decentralised Periphery) and PROFIBUS-PA (Process Automation). The RPBA-01 PROFIBUS DP Adapter module supports the PROFIBUS DP protocol, including its DP-V1 extension.

The physical transmission medium of the bus is a twisted pair cable (according to the RS-485 standard). The maximum length of the bus cable is 100 to 1200 metres, depending on the selected transmission rate (see Technical data chapter). Up to 31 nodes can be connected to the same PROFIBUS network segment without the use of repeaters. With repeaters, it is possible to connect 127 nodes (including repeaters and master station) to the network.

In PROFIBUS communication, the master station – usually a programmable logic controller (PLC) – polls the nodes which respond and take the actions requested by the master. It is also possible to send a command to several nodes at the same broadcast; in this case the nodes do not send a response message to the master.

The PROFIBUS protocol family is specified in the IEC 61158 standard. The communication with a drive is defined in the PROFIdrive Profile – The PROFIBUS Profile for Adjustable Speed

Drives. For further information on PROFIBUS, refer to the above-mentioned standards.

The RPBA-01 PROFIBUS DP Adapter module

The RPBA-01 PROFIBUS DP Adapter module is an optional device for ABB drives which enables the connection of the drive to a PROFIBUS network. The drive is considered as a slave on the PROFIBUS network. Through the RPBA-01 PROFIBUS DP Adapter module, it is possible to:

- give control commands to the drive (Start, Stop, Run enable, etc.)
- feed a motor speed or torque reference to the drive
- give a process actual value or a process reference to the PID controller of the drive
- read status information and actual values from the drive
- change drive parameter values
- reset a drive fault.

The PROFIBUS commands and services supported by the RPBA-01 PROFIBUS DP Adapter module are discussed in the chapters *DP-V0 communication* and *DP-V1 communication*. Please refer to the user documentation of the drive as to which commands are supported by the drive.

The adapter module is mounted into an option slot on the motor control board of the drive. See the Hardware Manual of the drive for module placement options.

Configuration of the master station requires a type definition (GSD) file. For DP-V0 communication, the file is available from **www.profibus.com** or an ABB representative (the filename is **ABB_0812.GSD**). For DP-V1 communication, the type definition (GSD) file is available from an ABB representative (the filename is **ABB10812.GSD**).

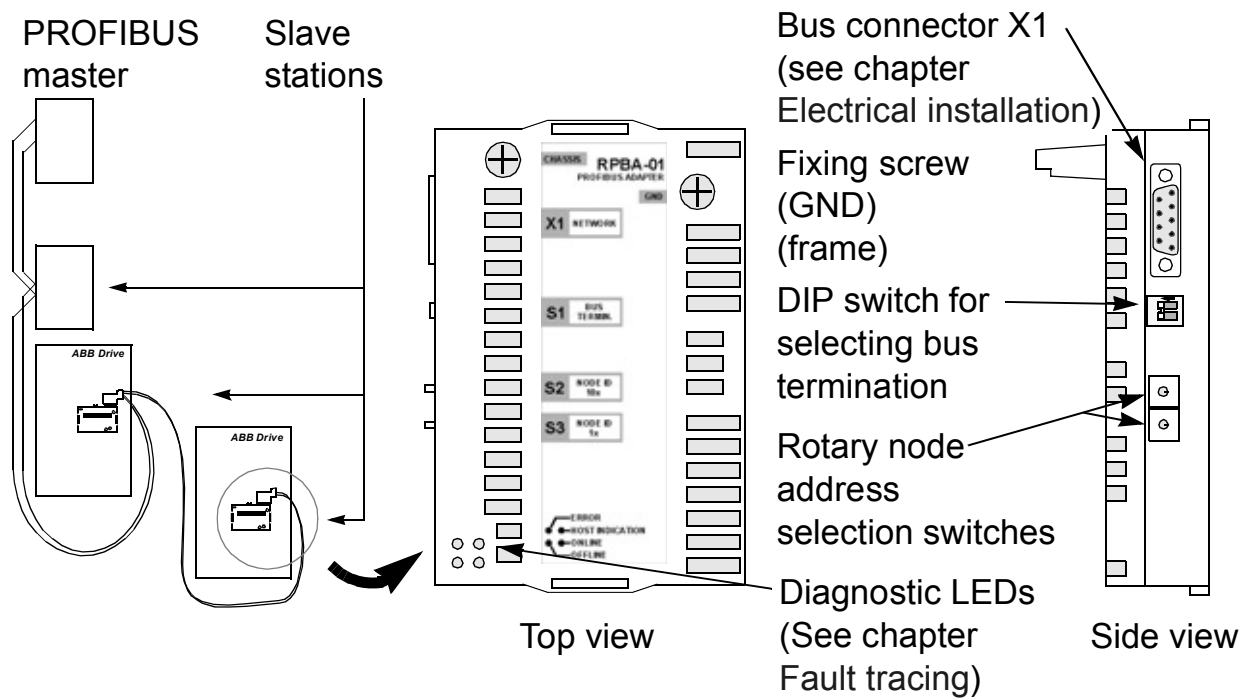

Figure 1. The construction of the PROFIBUS link and the RPBA-01 Adapter module.

Compatibility

The RPBA-01 is compatible with all master stations that support the PROFIBUS DP protocol.

Delivery check

The option package for the RPBA-01 PROFIBUS DP Adapter module contains:

- PROFIBUS DP Adapter module, type RPBA-01
- two screws (M3x10)
- this manual.

Warranty and liability information

The manufacturer warrants the equipment supplied against defects in design, materials and workmanship for a period of twelve (12) months after installation or twenty-four (24) months from date of manufacturing, whichever first occurs. The local ABB office or distributor may grant a warranty period different to the above and refer to local terms of liability as defined in the supply contract.

The manufacturer is not responsible for

- any costs resulting from a failure if the installation, commissioning, repair, alternation, or ambient conditions of the drive do not fulfil the requirements specified in the documentation delivered with the unit and other relevant documentation
- units subjected to misuse, negligence or accident
- units comprised of materials provided or designs stipulated by the purchaser.

In no event shall the manufacturer, its suppliers or subcontractors be liable for special, indirect, incidental or consequential damages, losses or penalties.

If you have any questions concerning your ABB drive, please contact the local distributor or ABB office. The technical data, information and specifications are valid at the time of printing. The manufacturer reserves the right to modifications without prior notice.

Quick start-up guide

Overview

This chapter presents the steps to take during the start-up of the RPBA-01 PROFIBUS DP Adapter Module. For more detailed information, see the chapters *Mechanical installation*, *Electrical installation*, and *Programming* elsewhere in this manual.



WARNING! Follow the safety instructions given in this manual and the *Hardware Manual* of the drive.

PLC configuration

- Install the RPBA-01 GSD file (e.g. ABB_0812.GSD).

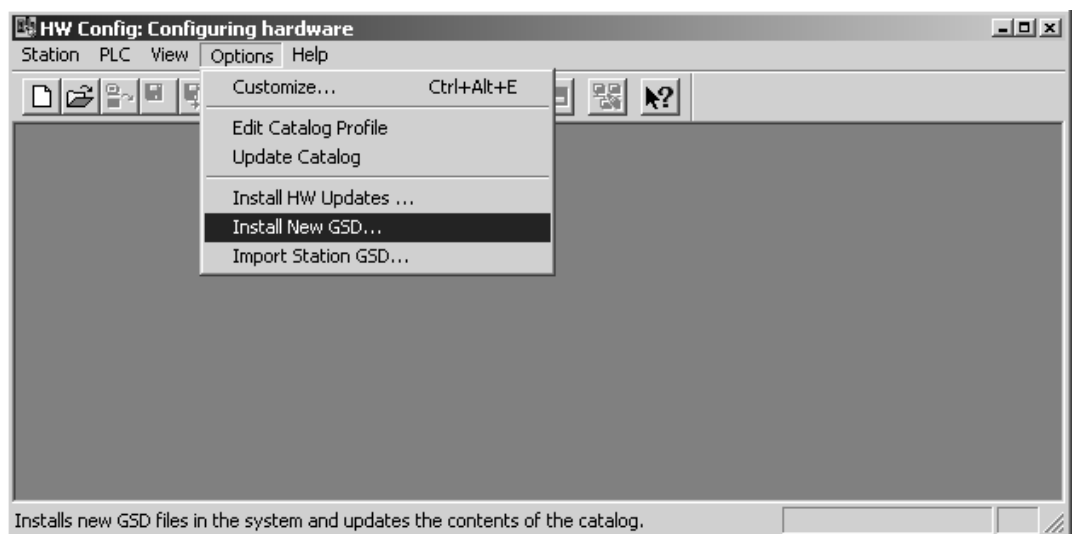

- Select the operation mode (PROFIDRIVE, i.e. Generic, or VENDOR SPECIFIC, i.e. ABB Drives).

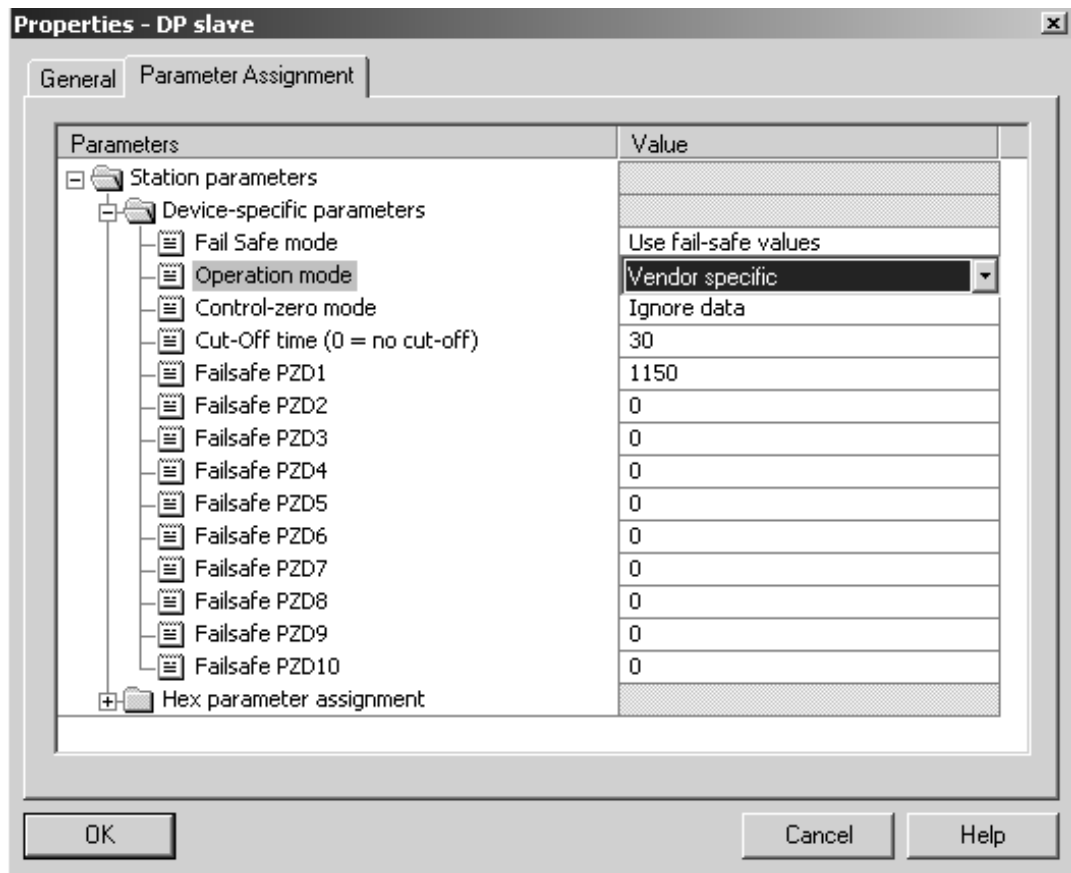

- Set the PPO type, baud rate and node number.

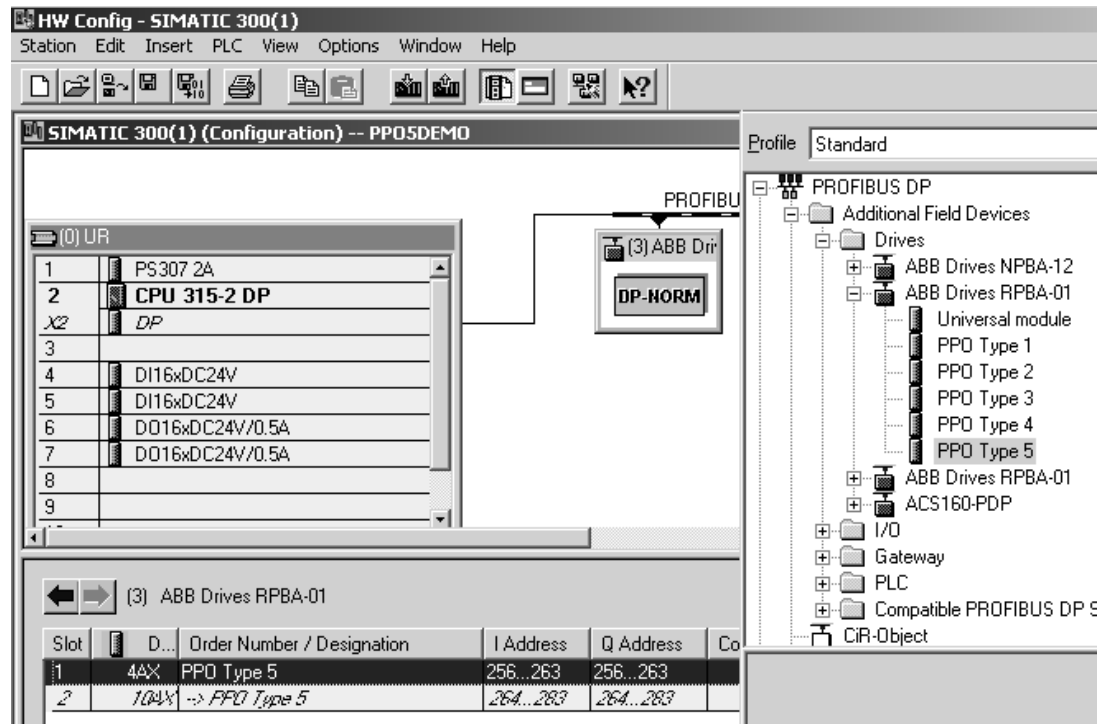

Mechanical and electrical installation

- Set the node address using the rotary switches on the module. (If the node address is set by software, set the switches to the “0” position.)
- Set the bus termination switch to the desired position.
- Insert the RPBA-01 into its specified slot in the drive (SLOT2 for ACS550, SLOT1 for ACS800).
- Fasten the two screws.
- Plug the fieldbus connector to the module.

Drive configuration

- Power up the drive.
- The detailed procedure of activating the drive for communication with the module is dependent on the drive type. Normally, a parameter must be adjusted to activate the communication. Refer to the *Firmware Manual* of the drive for

information on the communication settings. With an ACS550 drive, set parameter 98.02 COMM. MODULE LINK to EXT FBA. With an ACS800, set parameter 98.02 COMM. MODULE LINK to FIELDBUS and parameter 98.07 COMM PROFILE to ABB DRIVES or GENERIC (according to PLC hardware configuration).

- If the configuration is correct, parameter group 51 should appear in the parameter list of the drive and show the status of the bus configuration parameters.
- If the node address is to be set by software, set the required address at parameter 51.02 NODE ADDRESS.

Parameter setting examples

Generic drives profile (PROFIdrive) with PPO Type 1 (DP-V0)

| Drive parameter | Setting | |
|-------------------------|-----------|---------|
| | ACS800 | ACS550 |
| 10.01 EXT1 STRT/STP/DIR | COMM.CW | COMM |
| 11.03 EXT REF1 SELECT | COMM. REF | COMM |
| 16.01 RUN ENABLE | COMM.CW | COMM |
| 16.04 FAULT RESET SEL | COMM.CW | COMM |
| 98.02 COMM. MODULE LINK | FIELDBUS | – |
| 98.02 COMM PROT SEL | – | EXT FBA |
| 98.07 COMM PROFILE | GENERIC | – |

| | |
|-----------------------|--------------|
| 51.01 MODULE TYPE | PROFIBUS DP* |
| 51.02 NODE ADDRESS | 3 |
| 51.03 BAUDRATE | 12000* |
| 51.04 PPO-type | PPO1* |
| 51.21 DP MODE | 0 |
| 51.27 FBA PAR REFRESH | REFRESH |

*Read-only or automatically detected

The RPBA-01 uses data-consistent communication, meaning that the whole data frame is transmitted during a single program cycle. Some PLCs handle this internally, but others must be programmed to transmit data-consistent telegrams. For example,

Siemens Simatic S7 requires the use of special functions SFC15 and SFC14.

Network 3: Title:

Comment:

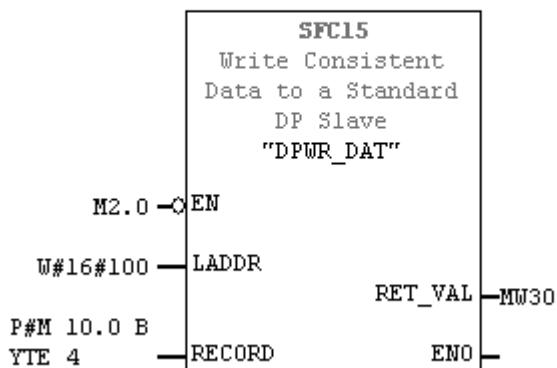

Network 3: Title:

Comment:

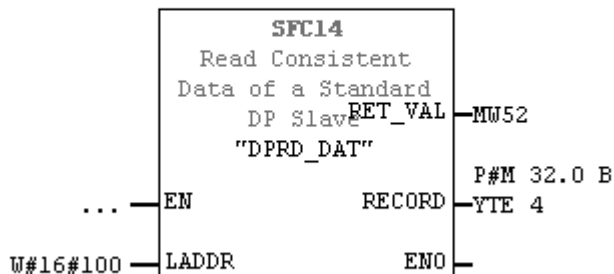

The start/stop commands and reference are according to the PROFIdrive profile. (See the PROFIBUS state machine on page 77.) The reference value ± 16384 (4000h) corresponds to the nominal speed of the motor (parameter 99.08) in forward and reverse directions.

ABB DRIVES profile (Vendor-specific) with PPO Type 2 (DP-V0)

| Drive parameter | Setting | |
|---|--------------------------|---------|
| | ACS800 | ACS550 |
| 10.01 EXT1 STRT/STP/DIR | COMM.CW | COMM |
| 10.02 EXT2 STRT/STP/DIR | COMM.CW | COMM |
| 11.02 EXT1/EXT2 SELECT | COMM.CW | COMM |
| 11.03 EXT REF1 SELECT | COMM. REF | COMM |
| 16.01 RUN ENABLE | COMM.CW | COMM |
| 16.04 FAULT RESET SEL | COMM.CW | COMM |
| 98.02 COMM. MODULE LINK | FIELD BUS | – |
| 98.02 COMM PROT SEL | – | EXT FBA |
| 98.07 COMM PROFILE | ABB DRIVES | – |
| 51.01 MODULE TYPE | PROFIBUS DP* | |
| 51.02 NODE ADDRESS | 4 | |
| 51.03 BAUDRATE | 1500* | |
| 51.04 PPO-TYPE | PPO2* | |
| 51.05 PZD3 OUT | 1202 (CONST SPEED 1)** | |
| 51.06 PZD3 IN | 104 (CURRENT)** | |
| 51.07 PZD4 OUT | 2501 (CRIT SPEED SEL)** | |
| 51.08 PZD4 IN | 105 (TORQUE)** | |
| 51.09 PZD5 OUT | 2502 (CRIT SPEED 1 LO)** | |
| 51.10 PZD5 IN | 106 (POWER)** | |
| 51.11 PZD6 OUT | 2503 (CRIT SPEED 1 HI)** | |
| 51.12 PZD6 IN | 107 (DC BUS VOLTAGE)** | |
| ••• | ••• | |
| 51.21 DP MODE | 0 | |
| 51.27 FBA PAR REFRESH | REFRESH | |
| *Read-only or automatically detected; **Example | | |

From the PLC programming point, the ABB DRIVES profile is similar to the Generic profile as shown in the first example.

The start/stop commands and reference are according to the ABB DRIVES profile. (See the drive manuals for more information.)

If REF1 is used, the reference value ± 20000 (decimal) corresponds to the speed or frequency set by parameter 11.05 (EXT REF1 MAXIMUM) in the forward and reverse directions. If REF2 is used, whether the limit 11.08 (EXT REF2 MAXIMUM) corresponds to ± 20000 or ± 10000 is dependent on the drive type and/or the application macro selected.

The minimum and maximum 16-bit integer values that can be given through the fieldbus are -32768 and 32767 respectively.

Mechanical installation



WARNING! Follow the safety instructions given in this manual and in the Hardware Manual.

Mounting

The RPBA-01 is to be inserted into its specific position in the drive. The module is held in place with plastic retaining clips and two screws. The screws also provide the earthing of the I/O cable shield connected to the module, and interconnect the GND signals of the module and the control board of the drive.

On installation of the module, the signal and power connection to the drive is automatically made through a 34-pin connector.

Mounting procedure:

- Insert the module carefully into its position inside the drive until the retaining clips lock the module into position.
- Fasten the two screws (included) to the stand-offs.
- Set the bus termination switch of the module to the required position.

Note: Correct installation of the screws is essential for fulfilling the EMC requirements and for proper operation of the module.

Note: Make sure the drive is properly grounded. For more information, see the drive documentation.

Electrical installation

Overview

This chapter contains:

- general cabling instructions
- instructions for setting module node address number and bus termination
- instructions for connecting the module to the PROFIBUS DP network.



WARNING! Before installation, switch off the drive power supply. Wait five minutes to ensure that the capacitor bank of the drive is discharged. Switch off all dangerous voltages connected from external control circuits to the inputs and outputs of the drive.

General cabling instructions

Arrange the bus cables as far away from the motor cables as possible. Avoid parallel runs. Use bushings at cable entries.

Bus termination

The DIP switch on the front of the RPBA-01 module is used to switch on bus termination. Bus termination prevents signal reflections from the cable ends. Bus termination must be set to ON if the module is the last or first module on the network. When using PROFIBUS specific D-sub connectors with built-in termination, the RPBA-01 termination must be switched off.

Note: The built-in termination circuitry of the RPBA-01 is of the active type, so the module has to be powered for the termination to work. If the module needs to be switched off during operation of the network, the bus can be terminated by connecting a 220 ohm, 1/4 W resistor between the A and B lines.

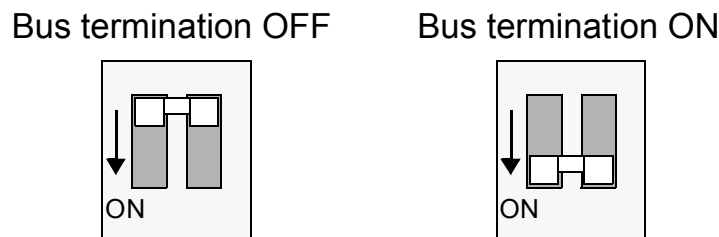

Figure 2. Bus termination switch

Node selection

Use the rotary node address selectors on the module to select the node address number. The node address number is a decimal number ranging from 01 to 99. The left selector represents the first digit and the right selector the second digit. The node address can be changed during operation, but the module must be re-initialised for changes to take effect.

Note: When 00 is selected, the node number is defined by a parameter in the fieldbus parameter group of the drive.

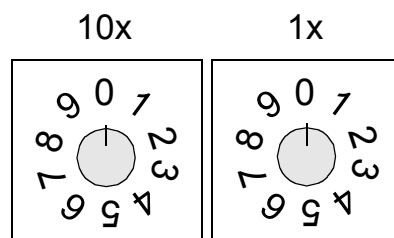
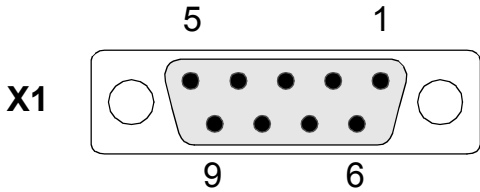

Figure 3. Node selectors

PROFIBUS connection

The bus cable is connected to connector X1 on the RPBA-01.

The connector pin allocation described below follows the PROFIBUS standard.



| X1 | | Description |
|---------|------------|--|
| 1 | | Not used |
| 2 | | Not used |
| 3 | B | Data positive (Conductor 1 in twisted pair). |
| 4 | RTS | Request To Send |
| 5 | GND BUS | Isolated ground |
| 6 | +5V | Isolated 5V DC voltage supply |
| 7 | | Not used |
| 8 | A | Data negative (Conductor 2 in twisted pair). |
| 9 | | Not used |
| Housing | SHLD | PROFIBUS cable shield. Internally connected to GND BUS via an RC filter and directly to CHGND. |

+5V and GND BUS are used for bus termination. Some devices, like optical transceivers (RS485 to fibre optics) might require external power supply from these pins.

RTS is used in some equipment to determine the direction of transmission. In normal applications only the line A, line B and shield are used.

PROFIBUS wiring example

The PROFIBUS cable shields are directly earthed at all nodes.

In the example below a recommended Siemens 6ES7 972-0BA12-0XA0 connector (not included in the delivery) is connected to the RPBA-01 module. The cable is a standard PROFIBUS cable consisting of a twisted pair and screen.

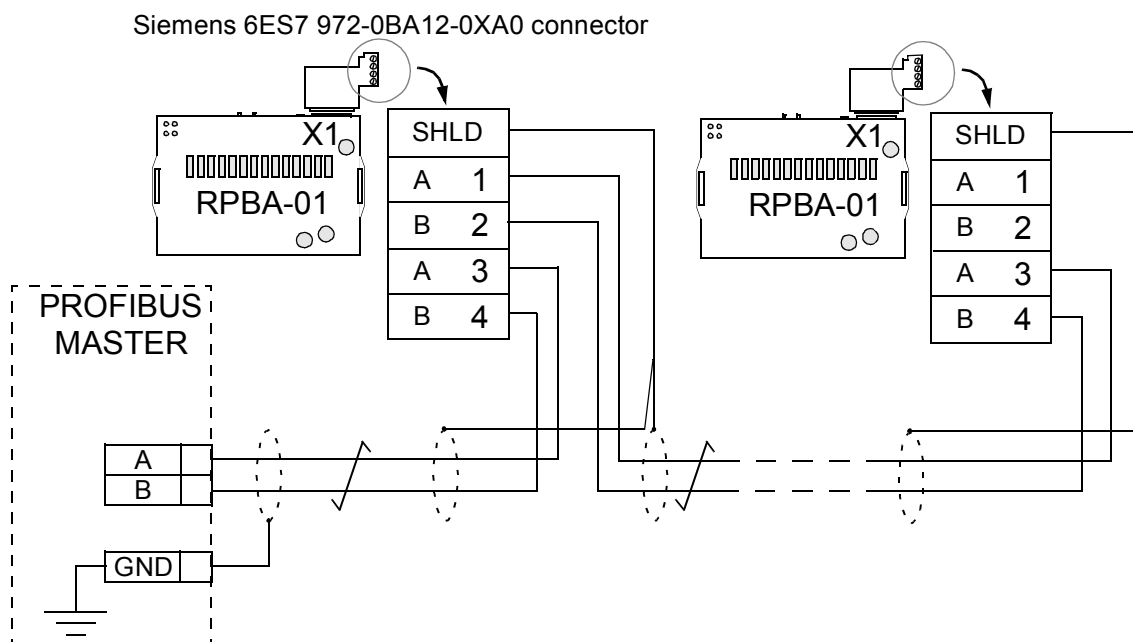

Figure 4. Connection diagram for the standard PROFIBUS cable

Note: Further information on PROFIBUS wiring is available from the publication “PROFIBUS RS 485-IS User and Installation Guideline” (www.profibus.com, order no. 2.262).

Programming

Overview

This chapter gives information on configuring the PROFIBUS master station and the drive for communication through the RPBA-01 PROFIBUS DP Adapter module.

Configuring the system

After the RPBA-01 PROFIBUS DP Adapter module has been mechanically and electrically installed according to the instructions in previous chapters, the master station and the drive must be prepared for communication with the module.

Configuration of the master station requires a type definition (GSD) file. For DP-V0 communication, the file is available from www.profibus.com or an ABB representative (the filename is **ABB_0812.GSD**). For DP-V1 communication, the type definition (GSD) file is available from an ABB representative (the filename is **ABB10812.GSD**).

Please refer to the master station documentation for more information.

PROFIBUS connection configuration

The detailed procedure of activating the module for communication with the drive is dependent on the drive type. (Normally, a parameter must be adjusted to activate the communication. See the drive documentation.)

As communication between the drive and the RPBA-01 is established, several configuration parameters are copied to the drive. These parameters – shown below in Table 5 – must be checked first and adjusted if necessary. The alternative selections for these parameters are discussed in more detail below the table.

Note: The new settings take effect only when the module is powered up the next time or when the module receives a 'Fieldbus Adapter parameter refresh' command from the drive.

Data transfer rates supported

The RPBA-01 supports the following PROFIBUS communication speeds: 9.6 kbit/s, 19.2 kbit/s, 45.45 kbit/s, 93.75 kbit/s, 187.5 kbit/s, 500 kbit/s, 1.5 Mbit/s, 3 Mbit/s, 6 Mbit/s, 12 Mbit/s.

The RPBA-01 automatically detects the communication speed and PPO-type used.

Table 5. The RPBA-01 configuration parameters.

| Par. no. | Parameter name | Alternative settings | Default setting |
|----------|-------------------------|---|-----------------|
| 1 | MODULE TYPE | (Read-only) | PROFIBUS DP |
| 2 | NODE ADDRESS | 0 to 126 | 3 |
| 3 | BAUD RATE ¹⁾ | (12000) 12 Mbit/s; (6000) 6 Mbit/s; (3000) 3 Mbit/s; (1500) 1.5 Mbit/s; (500) 500 kbit/s; (187) 187.5 kbit/s; (93) 93.75 kbit/s; (45) 45.45 kbit/s; (19) 19.2 kbit/s; (9) 9.6 kbit/s; (Read-only) | 1500 |
| 4 | PPO-TYPE ¹⁾ | (1) PPO 1; (2) PPO 2; (3) PPO 3; (4) PPO 4; (5) PPO 5; (6) PPO 6; (Read-only) | (1) PPO 1 |
| 5 | PZD3 OUT | 0 to 32767 with format xxyy, where xx = Parameter Group and yy = Parameter Index. See description below. | 0 |
| 6 | PZD3 IN | See PZD3 OUT above | 0 |
| 7 | PZD4 OUT | See PZD3 OUT above | 0 |
| 8 | PZD4 IN | See PZD3 OUT above | 0 |
| ... | ... | | |

| | | | |
|----|----------------|----------------------------------|------|
| 19 | PZD10 OUT | See PZD3 OUT above | 0 |
| 20 | PZD10 IN | See PZD3 OUT above | 0 |
| 21 | DP MODE | (0) DPV0; (1) DPV1 | 0 |
| 27 | FB PAR REFRESH | REFRESH; DONE | DONE |

¹⁾ The value is automatically updated (Read-only).

Note: Set also the extended Parameter Data (see page 67) to ensure proper operation of the RPBA-01 with the drive.

1 MODULE TYPE

This parameter shows the module type as detected by the drive. The value cannot be adjusted by the user.

If this parameter is undefined, the communication between the drive and the module has not been established.

2 NODE ADDRESS

Each device on the PROFIBUS network must have a unique node number. This parameter is used to define a node number for the drive it is connected to, if the node address selection switches are set to the zero position. When the node address selector switches are used to define the node address (node address selectors not in zero position) this parameter indicates the set node address.

3 BAUD RATE

Indicates the communication speed detected in kbit/s.

| | | | |
|-------|---|-------|--------|
| 12000 | = | 12 | Mbit/s |
| 6000 | = | 6 | Mbit/s |
| 3000 | = | 3 | Mbit/s |
| 1500 | = | 1.5 | Mbit/s |
| 500 | = | 500 | kbit/s |
| 187 | = | 187.5 | kbit/s |
| 93 | = | 93.75 | kbit/s |
| 45 | = | 45.45 | kbit/s |
| 19 | = | 19.2 | kbit/s |
| 9 | = | 9.6 | kbit/s |

4 PPO-TYPE

This parameter indicates the detected PPO message type for the PROFIBUS communication. See Figures 6 and 10 in the chapters *DP-V0 communication* and *DP-V1 communication* respectively for the supported PPO message types.

5 PZD3 OUT

This parameter represents process data word 3 of the PPO type received by the drive over the PROFIBUS network. The content is defined by a decimal number in the range of 0 to 32767 as follows:

| | |
|---------------|-----------------------------|
| 0 | not used |
| 1 - 99 | data set area of the drive |
| 101 - 9999 | parameter area of the drive |
| 10000 - 32767 | not supported by the drive |

| | |
|--|--------------------|
| The data set area is allocated as follows: | |
| 1 | data set 1 word 1 |
| 2 | data set 1 word 2 |
| 3 | data set 1 word 3 |
| 4 | data set 2 word 1 |
| 5 | data set 2 word 2 |
| 6 | data set 2 word 3 |
| 7 | data set 3 word 1 |
| ... | |
| 99 | data set 33 word 3 |

The parameter area is allocated as follows:

Parameter number with format *xyy*, where *xx* is the parameter group number (1 to 99) and *yy* is the parameter number index inside the group (01 to 99).

6 PZD3 IN

Process data word 3 of the PPO type sent from the drive to the PROFIBUS network.

The content is defined by a decimal number in the range of 0 to 32767. See parameter PZD3 OUT for description of decimal number allocation.

7 to 20 PZD4 OUT to PZD10 IN

See parameters PZD3 OUT and PZD3 IN.

21 DP MODE

Selects the PROFIBUS protocol version (DP-V0 or DP-V1).

Note: For DP-V0, GSD file version 1 or 2 (ABB_0812.GSD) must be used. For DP-V1, GSD file version 3 or higher (ABB10812.GSD) must be used.

27 FBA PAR REFRESH

Any parameter changes take effect only after the module is restarted. Alternatively, this parameter can be set to REFRESH. The parameter will automatically revert to DONE.

Control locations

ABB drives can receive control information from multiple sources including digital inputs, analogue inputs, the drive control panel and a communication module (e.g. RPBA-01). ABB drives allow the user to separately determine the source for each type of control information (Start, Stop, Direction, Reference, Fault Reset, etc.). In order to give the fieldbus master station the most complete control over the drive, the communication module must be selected as source for this information. See the user documentation of the drive for information on the selection parameters.

DP-V0 communication

Overview

This chapter describes the PROFIBUS messaging used in the communication with the drive when the RPBA-01 module is in DP-V0 mode.

PROFIBUS DP

The RPBA-01 module supports the PROFIBUS-DP protocol according to EN 50170 standard. PROFIBUS DP is a distributed I/O system which enables the master to use a large number of peripheral modules and field devices. The data transfer is mainly cyclic: the master reads the input information from the slaves and sends the output information back to the slaves.

The PROFIBUS DP protocol uses so-called PPOs (*Parameter/Process Data Objects*) in cyclic communication. See Figure 6 for the different PPO types and their composition.

Service Access Points

The services of the PROFIBUS Data Link Layer (Layer 2) are used by PROFIBUS DP through Service Access Points (SAPs). Precisely defined functions are assigned to individual SAPs.

For further information on Service Access Points, refer to the manual of the PROFIBUS master, *PROFIdrive – The PROFIBUS Profile for Adjustable Speed Drives (version 2.0)*, or the EN 50170 standard.

| | | |
|--|------------------|--|
| 7 | - | Reserved |
| Prm_Data (Parameter Data Extended) Type: Octet String - Length: 23 | | |
| 8 | 10h (default) | Header byte <p>0 0 0 1 0 0 0 0</p> <ul style="list-style-type: none"> Fail-safe mode. Defines the action taken when the PLC is switched from 'RUN' to 'STOP' mode. 00 = STOP (default) 01 = LAST SPEED 02 = USE FAIL-SAFE. The values of the PZDs are defined by bytes 11-30 in the Prm_Data telegram. Control zero mode. Defines the action taken if a PROFIBUS telegram containing only zeros is received. 00 = USE FRAME (default). Note that, with this setting, the drive might not be stopped (if it is running) since also bit 10 (Remote Command) in the control word is zero. However, the other PZD's may still be updated, but have the value zero. 01 = IGNORE Operation mode. Determines which control/status word and reference/actual values are used. 00 = PROFIDRIVE (i.e. Generic drive profile) 01 = VENDOR SPECIFIC (i.e. ABB Drives profile) (default). With this setting, <ul style="list-style-type: none"> • Fail-safe mode 'STOP' equals 'LAST SPEED' • the control word is forwarded unchanged to the drive • if the drive has a parameter for selection of operation mode (i.e. communication profile), make sure that the operation modes of the RPBA-01 and the drive match. Reserved |
| 9 - 10 | 0-65536 | Cut off time out in milliseconds. |
| 11 - 12 | 0-65536 | Fail-safe, PZD1 (CW) |
| 13 - 14 | 0-65536 | Fail-safe, PZD2 (REF) |
| 15 - 16 | 0-65536 | Fail-safe, PZD3 |
| 17 - 18 | 0-65536 | Fail-safe, PZD4 |
| 19 - 20 | 0-65536 | Fail-safe, PZD5 |
| 21 - 22 | 0-65536 | Fail-safe, PZD6 |
| 23 - 24 | 0-65536 | Fail-safe, PZD7 |

| | | |
|---------|---------|------------------|
| 25 - 26 | 0-65536 | Fail-safe, PZD8 |
| 27 - 28 | 0-65536 | Fail-safe, PZD9 |
| 29 - 30 | 0-65536 | Fail-safe, PZD10 |

The extended Parameter Data bytes are configured via the PROFIBUS network configuration tool. The functions are defined in the GSD file.

SAP 62 (Chk_Cfg)

SAP 62 selects the PPO type to be used. The table below gives the Hex values that must be sent to the drive to select the PPO type.

| Cfg_Data (Configuration Data) | | | |
|--------------------------------------|------------|----------------------|-----------------|
| Type: Octet String - Length: 4 to 28 | | | |
| PPO Type | Hex Values | Description | Length in Bytes |
| 1 | F3 F1 | 4 PKW + 2 PZD words | 12 |
| 2 | F3 F5 | 4 PKW + 6 PZD words | 20 |
| 3 | F1 | 0 PKW + 2 PZD words | 4 |
| 4 | F5 | 0 PKW + 6 PZD words | 12 |
| 5 | F3 F9 | 4 PKW + 10 PZD words | 28 |
| 6 | F9 | 0 PKW + 10 PZD words | 20 |

SAP 60 (Slave_Diag)

This SAP gives diagnostic information on the slave station.

| Diag_Data (Diagnostic Data) | |
|--|--|
| Type: Octet String - Length: 6 (Standard) + 2 (Extended Diagnosis) | |
| Byte | Description |
| 0 | <p>Station_Status_1</p> <ul style="list-style-type: none"> Diag.Station_Non_Existent (Set by Master, reset by Slave) Slave not found Diag.Stagion_Not_Ready (Set by Slave) Slave not ready for data exchange Diag.Cfg_Fault (Set by Slave) Received configuration data does not match original configuration data Diag.Ext_Diag (Set by Slave) Diagnostic entry present in slave-specific diagnostic area Diag.Not_Supported (Set by Slave) Service not supported by slave Diag.Invalid_Slave_Response (Set by Master, reset by Slave) Invalid response by slave Diag.Prm_Fault (Set by Slave) Invalid parameter or parameter value Diag.Master_Lock (Set by Master, reset by Slave) Slave is parameterised by another master |
| 1 | <p>Station_Status_2</p> <ul style="list-style-type: none"> Diag.Prm_Req (Set by Slave) Slave requires re-configuration and re-parameterisation Diag.Stat_Diag (Set by Slave) Static diagnosis. Slave (temporarily) unable to provide valid data Always set to 1 by slave Diag.WD_On (Set by Slave) Watchdog on Diag.Freeze_Mode (Set by Slave) Freeze command received by slave Diag.Sync_Mode (Set by Slave) Sync command received by slave Reserved Diag.Deactivated (Set by Master, reset by Slave) Slave is inactive |

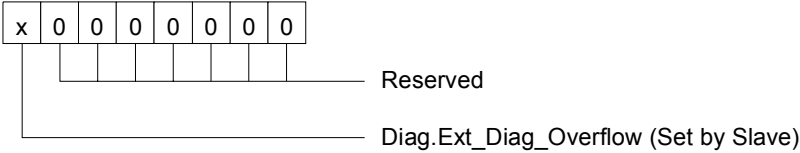
| Diag_Data (Diagnostic Data) Type: Octet String - Length: 6 (Standard) + 2 (Extended Diagnosis) | |
|--|--|
| Byte | Description |
| 2 | Station_Status_3  |
| 3 | Diag.Master_Add The address of the master that parameterised this slave |
| 4 - 5 | Ident_Number (for RPBA-01: 0812h) |
| 6 | Ext_Diag_Data The number of bytes reserved for Extended Diagnosis (including this byte) Fixed to 2 |
| 7 | Ext_Diag_Data Bit 0 = Communication temporarily lost Bit 1 = Communication permanently lost Bit 2 - 7 = Not used |

SAP 0 (Data_Exchange)

Allows the master to send output data to a slave station and to simultaneously request input data from the same station.

| |
|---|
| Outp_Data (Output Data) Type: Octet String - Length: 4 to 28 (depending on the selected PPO Type) |
| Inp_Data (Input Data) Type: Octet String - Length: 4 to 28 (depending on the selected PPO Type) |

PPO message types

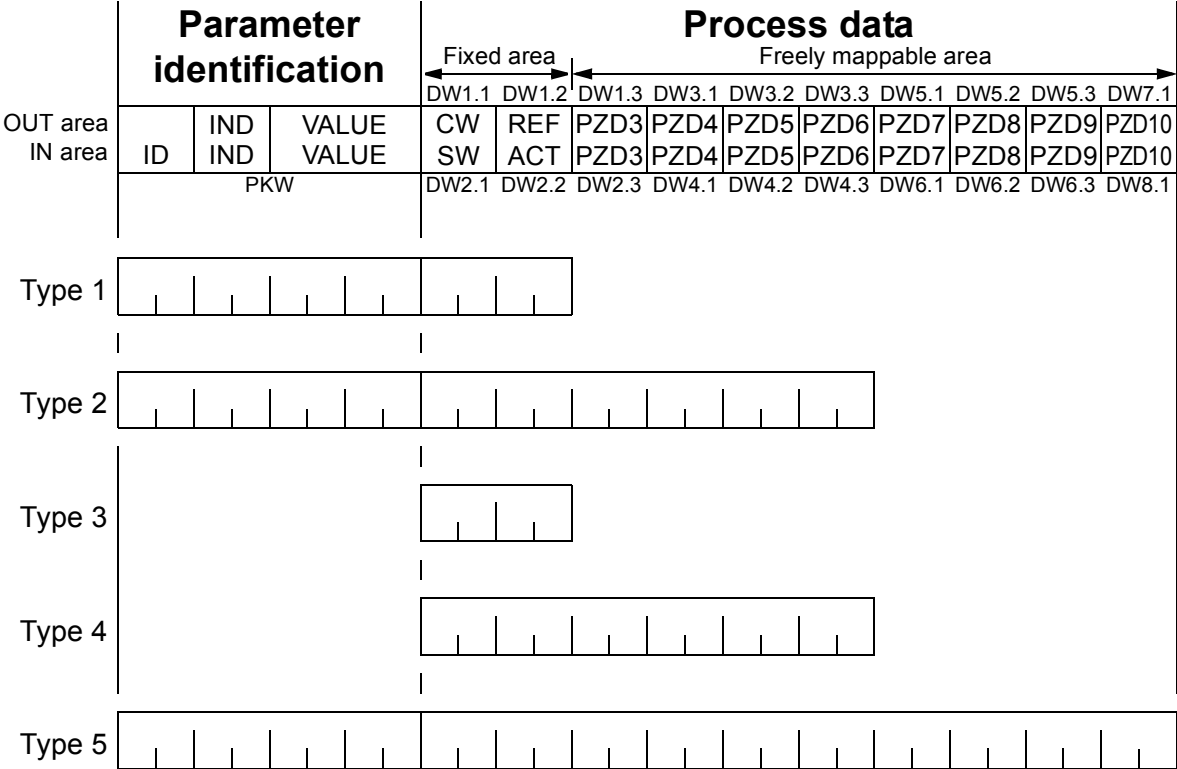

OUT area – Data sent from Master to Slave (control data)
IN area – Data sent from Slave to Master (actual data)

Parameter Identification:
 ID – Parameter Identification
 IND – Index for Arrays
 VALUE – Parameter Value (Max. 4 bytes)
 PKW –Parameter ID/Value

Process Data:
 CW – Control Word (see Table 7.)
 SW – Status Word (see Table 8.)
 REF – Reference
 ACT – Actual Value
 PZD – Process Data (application-specific)
 DW – Data Word

Figure 6. PPO message types

The Control Word and the Status Word

The Control Word (PROFIBUS Parameter 967) is the principal means for controlling the drive from a fieldbus system. It is sent by the fieldbus master station to the drive, the adapter module acting as a gateway. The drive switches between its states according to the bit-coded instructions on the Control Word, and returns status information to the master in the Status Word (PROFIBUS Parameter 968).

The contents of the Control Word and the Status Word are detailed in Tables 7 and 8 respectively; see the drive documentation for information on the drive-specific bits. The drive states are presented in the PROFIBUS State Machine (Figure 9).

References

References are 16-bit words containing a sign bit and a 15-bit integer. A negative reference (indicating reversed direction of rotation) is formed by calculating the two's complement from the corresponding positive reference.

ABB drives can receive control information from multiple sources including analogue and digital inputs, the drive control panel and a communication module (e.g. RPBA-01). In order to have the drive controlled through PROFIBUS, the communication module must be defined as the source for control information, e.g. Reference.

In the Vendor Specific mode, the scaling of the integer received from the master as Reference is drive-specific. See its programming manual for available control source selections and Reference scaling factors.

In PROFIdrive mode, the speed reference (REF) in hexadecimal (0...4000h) corresponds to 0...'motor nominal speed'.

Actual Values

Actual Values are 16-bit words containing information on the operation of the drive. The functions to be monitored are selected by a drive parameter. The scaling of the integers sent to the

master as Actual Values depends on the selected function, refer to the drive documentation.

In PROFIdrive mode, the actual speed (ACT) in hexadecimal (0...4000h) corresponds to 0...'motor nominal speed'.

Table 7. The Control Word (PROFIBUS Parameter 967). The upper case boldface text refers to the states shown in Figure 9.

| Bit | Name | Value | Proceed to STATE/Description |
|-----|------------------|-------|--|
| 0 | ON | 1 | Proceed to READY TO OPERATE |
| | OFF1 | 0 | Emergency OFF, stop by the selected deceleration ramp. Proceed to OFF1 ACTIVE ; proceed further to READY TO SWITCH ON unless other interlocks (OFF2, OFF3) are active |
| 1 | OFF2 | 1 | Continue operation (OFF2 inactive) |
| | | 0 | Emergency OFF, coast to stop. Proceed to OFF2 ACTIVE ; proceed further to SWITCH-ON INHIBIT |
| 2 | OFF3 | 1 | Continue operation (OFF3 inactive) |
| | | 0 | Emergency stop, stop according to fastest possible deceleration mode. Proceed to OFF3 ACTIVE ; proceed further to SWITCH-ON INHIBIT . Warning: Ensure motor and driven machine can be stopped using this stop mode. |
| 3 | OPERATION_ENABLE | 1 | Proceed to ENABLE OPERATION |
| | | 0 | Inhibit operation. Proceed to OPERATION INHIBIT |
| 4 | RAMP_OUT_ZERO | 1 | Normal operation. Proceed to RAMP FUNCTION GENERATOR: ENABLE OUTPUT |
| | | 0 | Stop according to selected stop type |
| 5 | RAMP_HOLD | 1 | Normal operation. Proceed to RAMP FUNCTION GENERATOR: ENABLE ACCELERATOR |
| | | 0 | Halt ramping (Ramp Function Generator output held) |

| Bit | Name | Value | Proceed to STATE/Description |
|----------|--------------|--|---|
| 6 | RAMP_IN_ZERO | 1 | Normal operation. Proceed to OPERATING |
| | | 0 | Force Ramp Function Generator input to zero |
| | | Note: The function of this bit may depend on the ramp parameter settings of the drive. See the drive documentation. | |
| 7 | RESET | 0 ⇒ 1 | Fault reset if an active fault exists. Proceed to SWITCH-ON INHIBIT. |
| | | 0 | (Continue normal operation) |
| 8 | INCHING_1 | | Inching 1. (See the drive documentation for information) |
| 9 | INCHING_2 | | Inching 2. (See the drive documentation for information) |
| 10 | REMOTE_CMD | 1 | Fieldbus control enabled |
| | | 0 | Control Word <> 0 or Reference <> 0: Retain last Control Word and Reference Control Word = 0 and Reference = 0: Fieldbus control enabled |
| 11 to 15 | | | Drive-specific. (See the drive documentation for information) |

Table 8. The Status Word (PROFIBUS Parameter 968). The upper case boldface text refers to the states shown in Figure 9.

| Bit | Name | Value | STATE/Description |
|-----|---------|-------|-------------------------------|
| 0 | RDY_ON | 1 | READY TO SWITCH ON |
| | | 0 | NOT READY TO SWITCH ON |
| 1 | RDY_RUN | 1 | READY TO OPERATE |
| | | 0 | OFF1 ACTIVE |
| 2 | RDY_REF | 1 | ENABLE OPERATION |
| | | 0 | DISABLE OPERATION |
| 3 | TRIPPED | 1 | FAULT |
| | | 0 | No fault |

| Bit | Name | Value | STATE/Description |
|----------|--------------|-------|---|
| 4 | OFF_2_STA | 1 | OFF2 inactive |
| | | 0 | OFF2 ACTIVE |
| 5 | OFF_3_STA | 1 | OFF3 inactive |
| | | 0 | OFF3 ACTIVE |
| 6 | SWC_ON_INHIB | 1 | SWITCH-ON INHIBIT ACTIVE |
| | | 0 | SWITCH-ON INHIBIT NOT ACTIVE |
| 7 | ALARM | 1 | Warning/Alarm |
| | | 0 | No Warning/Alarm |
| 8 | AT_SETPOINT | 1 | OPERATING. Actual value equals reference value (i.e. is within tolerance limits) |
| | | 0 | Actual value differs from reference value (= is outside tolerance limits) |
| 9 | REMOTE | 1 | Drive control location: REMOTE |
| | | 0 | Drive control location: LOCAL |
| 10 | ABOVE_LIMIT | 1 | Actual frequency or speed value equals or is greater than supervision limit. |
| | | 0 | Actual frequency or speed value is within supervision limit. |
| 11 to 15 | | | Drive-specific |

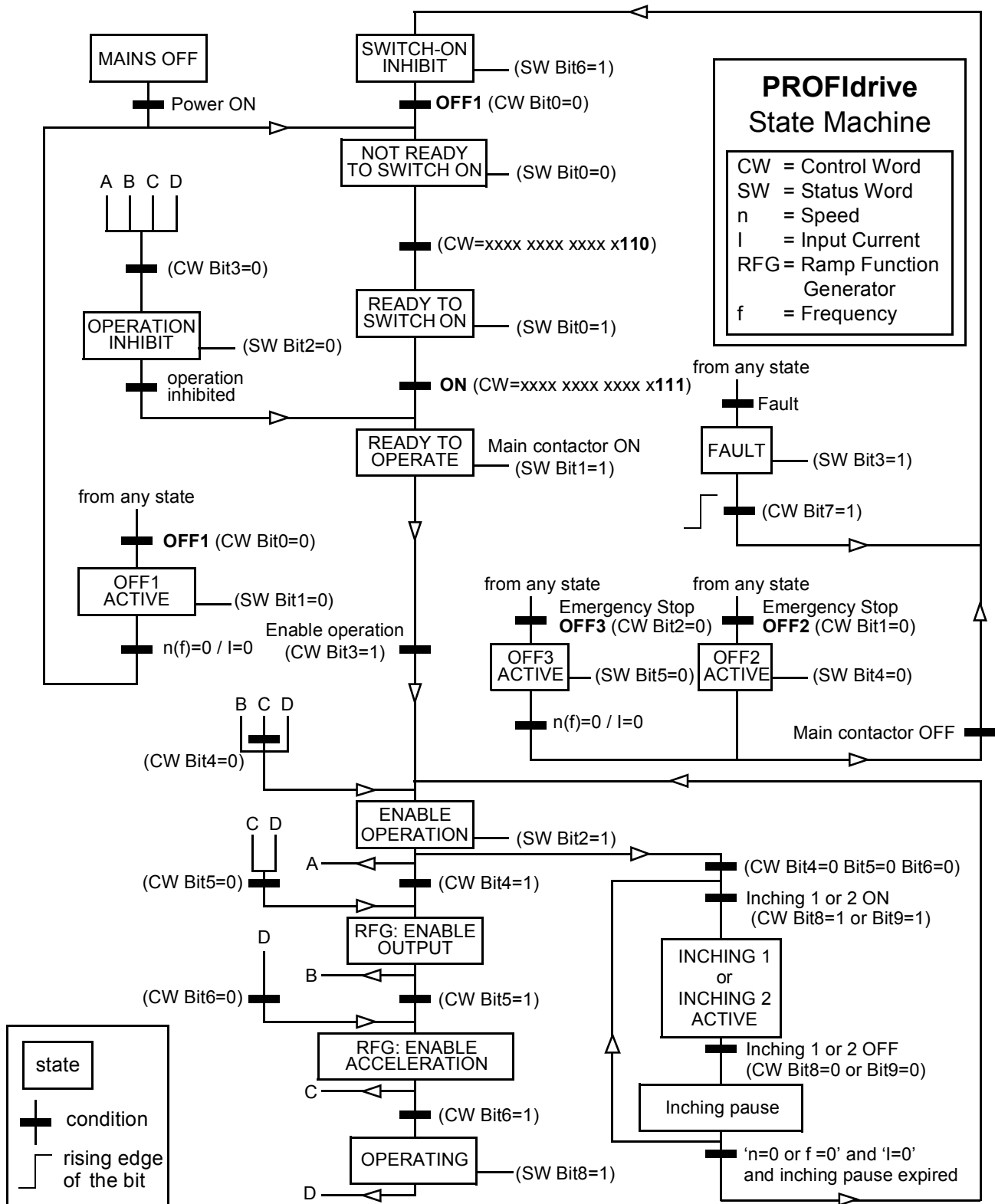
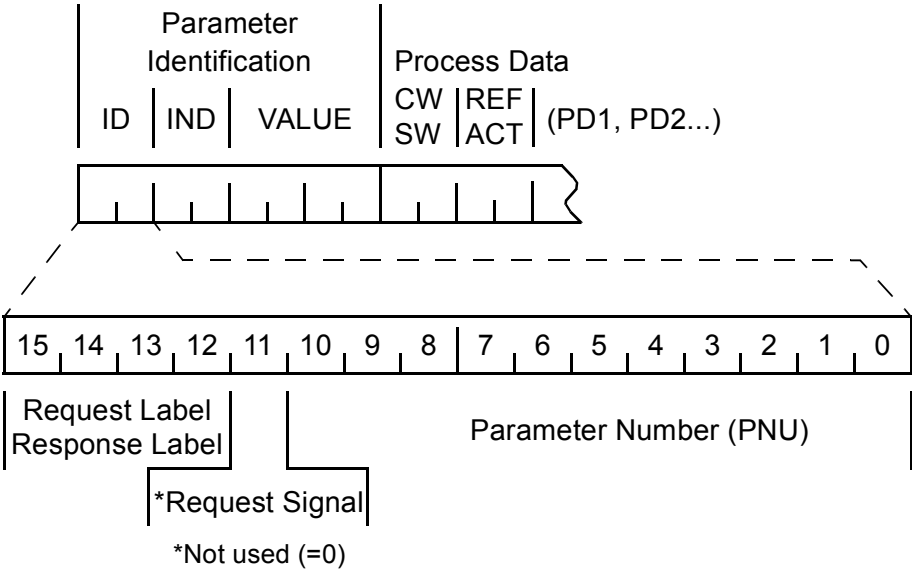

Figure 9. The PROFdrive state machine

Parameter handling in cyclic communication (DP)

In cyclic PROFIBUS DP communication, parameter data is transferred in PPO message types 1, 2 and 5 (see Figure 6.). The Parameter Identification part consists of eight bytes (see below).



The Request Label is used by the master when transmitting data to the slave, while the Response Label is used by the slave as a positive or negative acknowledgement. The tables below show the Request/Response functions.

| Request labels (from Master to Slave) | | Response labels | |
|---------------------------------------|---|-----------------|-----------|
| Request | Function | Ackn. (+) | Ackn. (-) |
| 0 | No task | 0 | – |
| 1 | Request parameter value | 1, 2 | 7 |
| 2 | Change parameter value (word) | 1 | 7, 8 |
| 3 | Change parameter value (double word) | 2 | 7, 8 |
| 4 | Request description element (not supported) | 3 | 7 |
| 5 | Change description element (not supported) | 3 | 7, 8 |
| 6 | Request parameter value (array) | 4, 5 | 7, 8 |
| 7 | Change parameter value (array word) | 4 | 7, 8 |
| 8 | Change parameter value (array double word) | 5 | 7,8 |
| 9 | Request number of array elements | 6 | 7 |

| Response label (Acknowledgement from Slave to Master) | |
|--|--|
| Ackn. | Function |
| 0 | No response |
| 1 | Transfer parameter value (word) |
| 2 | Transfer parameter value (double word) |
| 3 | Transfer description element |
| 4 | Transfer parameter value (array word) |
| 5 | Transfer parameter value (array double word) |
| 6 | Transfer number of array elements |
| 7 | <p>Task cannot be executed, followed by error number</p> <ul style="list-style-type: none"> 0 = Illegal parameter number 1 = Parameter value cannot be changed 2 = Lower or upper limit violated 3 = Erroneous subindex 4 = No array 5 = Incorrect data type 6 = Setting not allowed (can only be reset) 7 = Descriptive element cannot be changed 9 = Descriptive data not available 11 = No parameter change rights 15 = Text array not available 17 = Task cannot be executed due to operating status (e.g. parameter is currently read-only) 18 = Other error 101 = Vendor specific error 102 = Request not supported 103 = Request cannot be completed due to communication error 110 = Failure during write to non-volatile memory 111 = Request aborted due to time-out 120 = Parameter cannot be mapped to PZD (size mismatch or non-existent) 121 = Parameter cannot be mapped to PZD (end of memory) 122 = Parameter cannot be mapped to PZD (multiple PZD write) 130 = Cannot map Control Word bit (parameter 933 - 937, e.g. double mapping of bits) 140 = Cannot change mode to TORQUE (frequency is used) |
| 8 | No parameter change rights for PKW interface |
| 9 | Parameter data signal (word) |
| 10 | Parameter data signal (double word) |

The allocation of data sets, drive parameters and PROFIdrive parameters to the Parameter Identification part of the PPO type is shown below. The **Index** column corresponds to the parameter number (PNU) in the ID part of Parameter Identification. The **Sub-index** column corresponds to the IND part of Parameter Identification. The **Example No.** column refers to the examples on the following pages.

| Data set area | | | | | |
|---------------|-----------|-----------------|---------------|-----|-------------|
| Index | Sub-index | Range (Decimal) | Request Label | | Example No. |
| 0h | 1h | 1 | R/W | 6/7 | 1, 2 |
| 0h | 2h | 2 | | | |
| ... | | | | | |
| 0h | 63h | 99 | | | |

| Drive parameters | | | | | |
|------------------|-----------|-----------------|---------------|-----|-------------|
| Index | Sub-index | Range (Decimal) | Request Label | | Example No. |
| 0h | 65h | 101 | R/W* | 6/7 | 1, 2 |
| 0h | 66h | 102 | | | |
| ... | | | | | |
| 27h | 0Fh | 9999 | | | |

*Write access depends on drive parameter type, or operation mode.

| PROFIdrive parameters | | | | | | |
|-----------------------|-----------|-----------------|-----|---------------|-----|-------------|
| Index | Sub-index | Range (Decimal) | | Request Label | | Example No. |
| 393h | 2h | 915 | 2 | R/W | 6/7 | 6 |
| | 3h | | 3 | | | |
| | ... | | ... | | | |
| | 9h | | 9 | | | |
| 394h | 2h | 916 | 2 | R/W | 6/7 | 7 |
| | 3h | | 3 | | | |
| | ... | | ... | | | |
| | 9h | | 9 | | | |
| 396h | 0h | 918 | | R/W | 1/2 | 3, 4 |
| ... | | | | | | |
| 3B3h | 0h | 947 | 1 | R | 6 | 5 |
| | 9h | | 9 | | | |
| | 11h | | 17 | | | |
| | 19h | | 25 | | | |
| | 21h | | 33 | | | |
| | 29h | | 41 | | | |
| ... | | | | | | |
| 3CCh | 0h | 972 | | R/W | 1/2 | 3,4 |

The complete PROFIdrive parameter list for the RPBA-01 can be found as a separate chapter elsewhere in this manual.

Note: Continuous (cyclic) writing of PROFIdrive parameters should be avoided as the values of these parameters are stored in the flash memory of the RPBA-01. The estimated lifetime of the flash memory is 1,000,000 program/erase cycles, and continuous writing will cause the memory to fail prematurely.

Example 1: Reading a drive parameter (or data set)

To determine the parameter number and subindex for drive parameter reading, multiply the parameter number by one hundred and then convert it to hexadecimal. The low byte is the subindex (IND), and the high byte is the parameter number (PNU).

For example reading parameter 84.11 INPUT 1 from the drive:

$$84.11 \times 100 = 8411 = 20DBh.$$

Parameter number is 20 and subindex is DB.

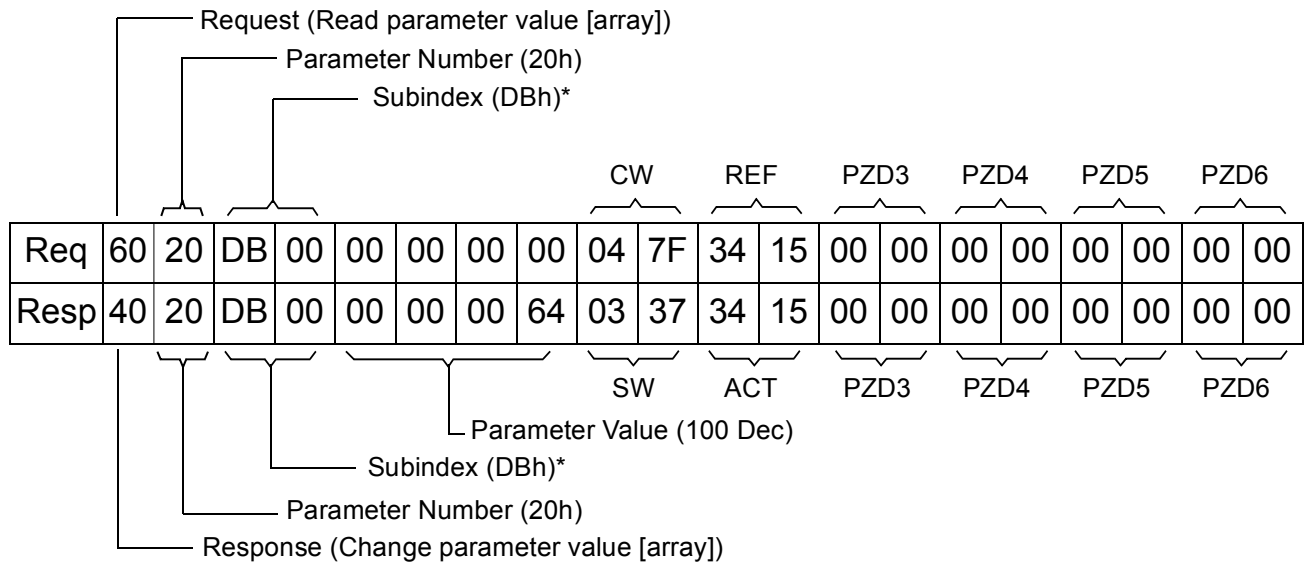

*2nd byte reserved

Example 2: Writing a drive parameter (or data set)

To determine the parameter number and subindex for drive parameter writing, multiply the parameter number by one hundred and then convert it to hexadecimal. The low byte is the subindex (IND), and the high byte is the parameter number (PNU). For example write parameter 12.02 CONSTANT SPEED.1:

$$12.02 \times 100 = 1202 = 04B2h.$$

Parameter is 04 and subindex is B2.

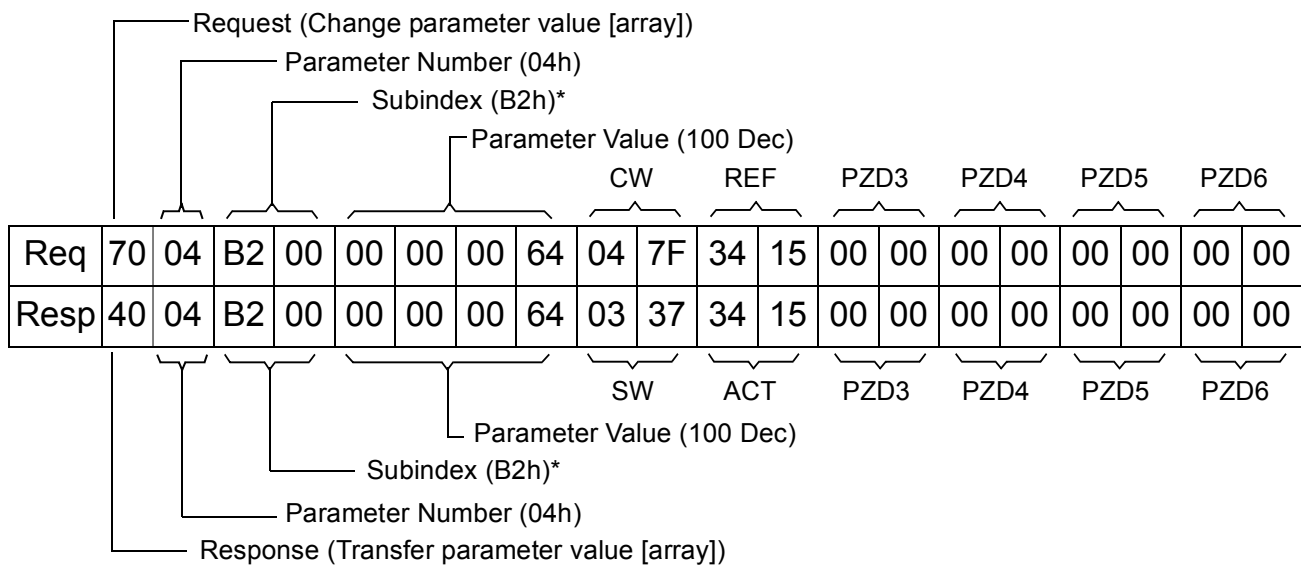

*2nd byte reserved

Example 3: Reading a PROFIdrive parameter (word)

In this example, PROFIBUS Parameter No. 918 is used to read the station number of the slave.

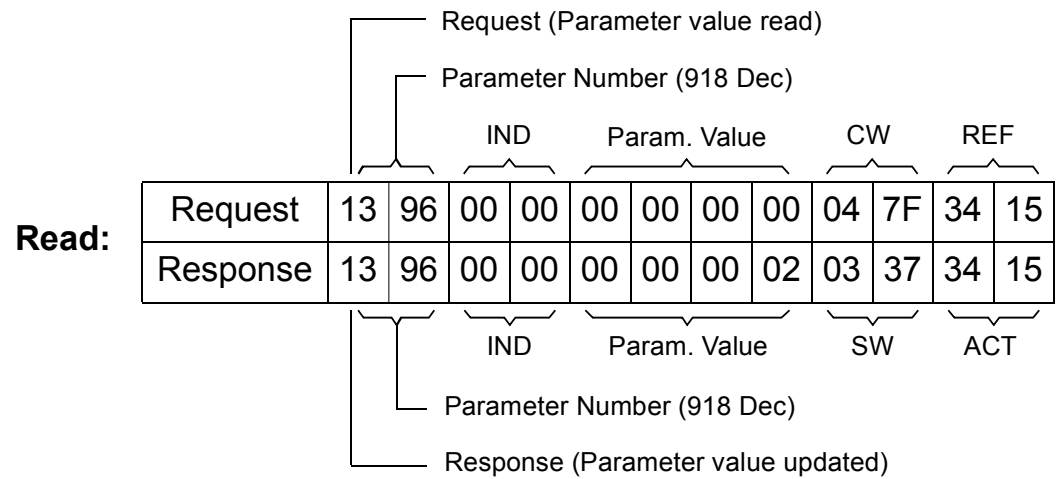

The slave returns its station number (2).

Example 4: Writing a PROFIdrive parameter (word)

In this example, current parameter settings are saved to the FLASH memory of the drive. This is done by setting the value of PROFIBUS Parameter No. 971 (3CBh) to 1.

Note that the drive always observes the Control Word (CW) and Reference (REF) bytes. The values shown below are examples.

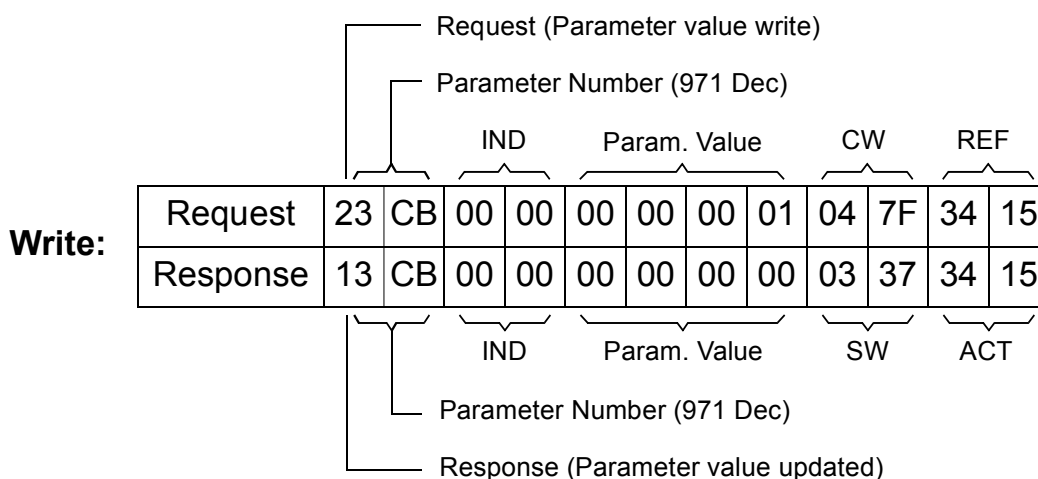

Example 5: Reading a PROFIdrive parameter (array)

In this example, PROFIBUS Parameter No. 945 is used to read the code of the latest acknowledged fault. As shown in Table 22 on page 103, parameter 945 is of the array type with subindexes 1, 9, 17 and 25.

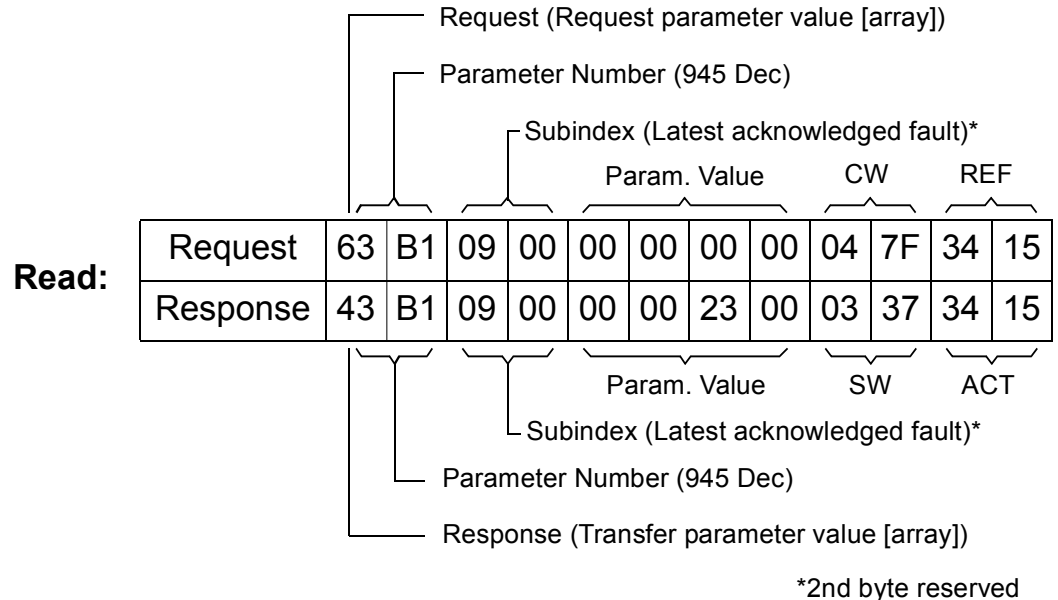

The slave returns the code of the latest acknowledged fault (2300h). The fault codes are according to the DRIVECOM standard. See also the User's Manual of the drive for drive specific fault codes.

The implementation of the PROFIdrive profile in the RPBA-01 supports the storage of the active and the five latest occurred different faults in the fault buffer. The fault codes can be accessed by PROFIdrive parameters 945 and 948 (see Table 22 on page 101). The value zero indicates no fault. The subindexes of these parameters are related to each other, i.e. parameter 945 with subindex 1 relates to subindex of parameter 948.

Example 6: Configuring the process data written to the drive

PROFIBUS parameter 915 can be used to define which data is written cyclically to a drive parameter as application-specific process data.

In the example below, the value of drive parameter 12.02 CONSTANT SPEED 1 (4B2h) is selected to be taken from PZD3. The parameter will continue to be updated with the contents of PZD3 in each Request frame until a different selection is made.

Subindex (IND) defines which process data word the required data is taken from. *Parameter Value* selects the drive parameter to which that word is mapped.

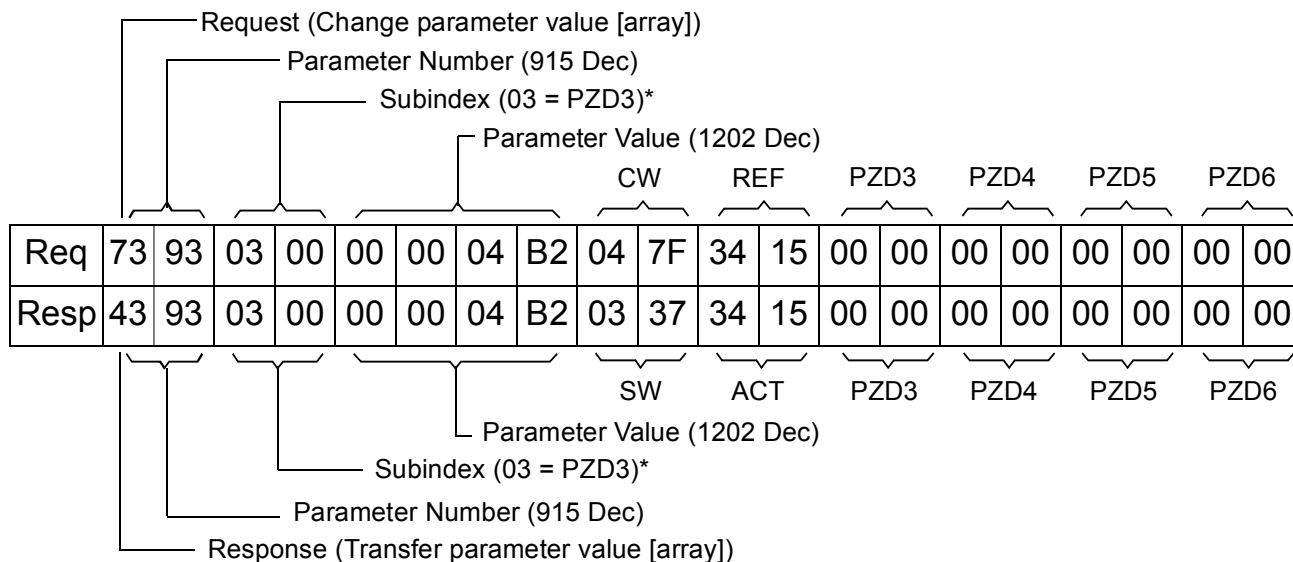

*2nd byte reserved

Subsequently, the contents of PZD3 in each Request frame are written to drive parameter 12.02 CONSTANT SPEED 1 until a different selection is made.

Example 7: Configuring the process data read from the drive

PROFIBUS Parameter No. 916 can be used to define which data is read cyclically from the drive as application-specific process data.

In the example below, drive parameter 1.04 CURRENT (68h) is selected to be transmitted by the drive as PZD3. The selection is in force until it is superseded by another selection.

Subindex (IND) defines which process data word the required data is transmitted in, and *Parameter Value* defines which drive parameter is mapped to that word.

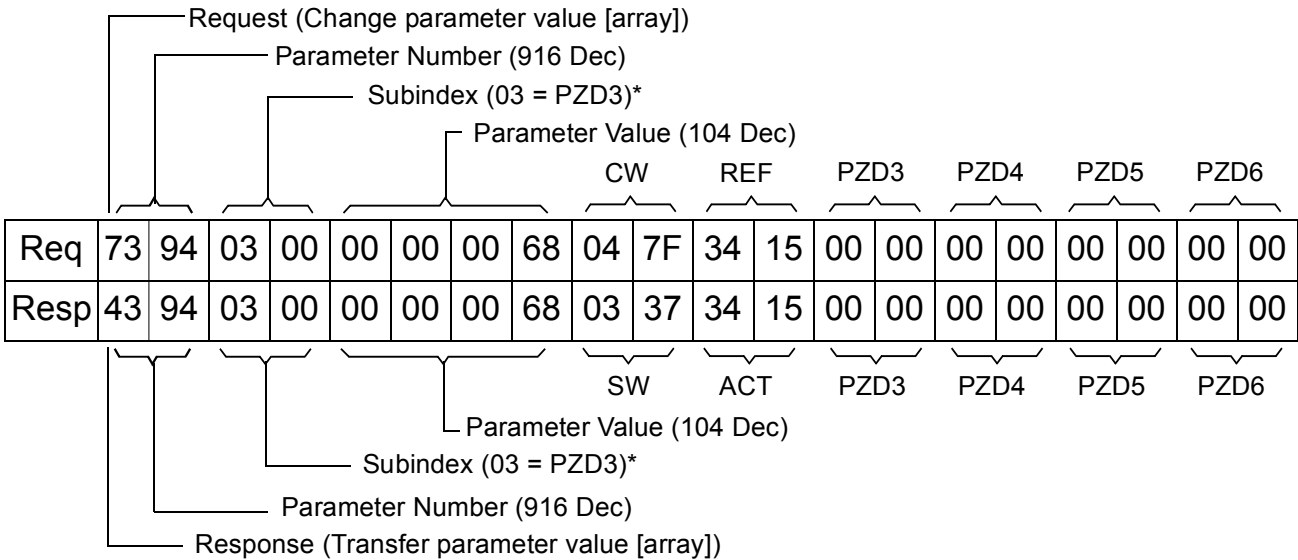

*2nd byte reserved

Subsequent response frames:

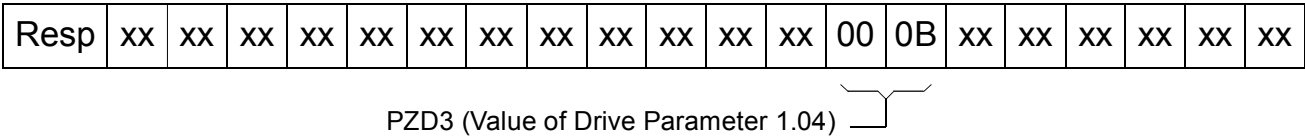

DP-V1 communication

Overview

This chapter describes the PROFIBUS messaging used in the communication with the drive when the RPBA-01 module is in DP-V1 mode.

PROFIBUS DP

The RPBA-01 module supports the PROFIBUS-DP protocol according to EN 50170 standard. PROFIBUS DP is a distributed I/O system which enables the master to use a large number of peripheral modules and field devices. The data transfer is mainly cyclic: the master reads the input information from the slaves and sends the output information back to the slaves.

The PROFIBUS DP protocol uses so-called PPOs (*Parameter/Process Data Objects*) in cyclic communication. See Figure 10 for the different PPO types and their composition.

Service Access Points

The services of the PROFIBUS Data Link Layer (Layer 2) are used by PROFIBUS DP through Service Access Points (SAPs). Precisely defined functions are assigned to individual SAPs.

For further information on Service Access Points, refer to the manual of the PROFIBUS master, *PROFIdrive – The PROFIBUS Profile for Adjustable Speed Drives (version 3.1)*, or the EN 50170 standard.

Communication start-up

The following Service Access Points (SAPs) are used to initiate DP communication:

| SAP no. | Short Name | Name |
|-----------------|------------|-----------------------------------|
| 51 | Server_SAP | Acyclic Read/Write |
| 61 | Set_Prm | Send Parameter Data |
| 62 | Chk_Cfg | Check Configuration Data |
| 60 | Slave_Diag | Read Slave Diagnostic Information |
| 0 (Default SAP) | Data_Exch | Transfer Input and Output Data |

SAP 61 (Set_Prm)

This SAP is used in the parameterisation of the drive.

| Prm_Data (Parameter Data Standard) Type: Octet String - Length: 8 | | |
|--|-------|---|
| Byte | Value | Description |
| 0 | B8h | <p>Station_Status</p> <p>MSB 1 0 1 1 1 0 0 0 LSB</p> <ul style="list-style-type: none"> Reserved WD_On 1 = Watchdog on Freeze_Req 1 = Slave is requested to process in freeze mode Sync_Req 1 = Slave is requested to process in SYNC mode 00 = Min TSDR and slave-related parameters may be overwritten Unlock_Req } 10 = Slave locked for other masters. Lock_Req } All parameters can be carried over x1 = Slave released for other masters |
| 1 - 2 | | Watchdog Factors 1 and 2 (set by the PROFIBUS master) WdFactor1 × WdFactor2 × 10 ms = monitoring time of the slave to verify that the master is still active. |
| 3 | 0Bh | Minimum Station Delay Respond Time Time after which a slave station is allowed to send response frames to the master. Calculated by multiplying the hex value with t_{Bit} (time required for transmitting one bit). |
| 4 - 5 | 0812h | Vendor Identification (for the RPBA-01: 0812h) |
| 6 | 00h | Group Identification |

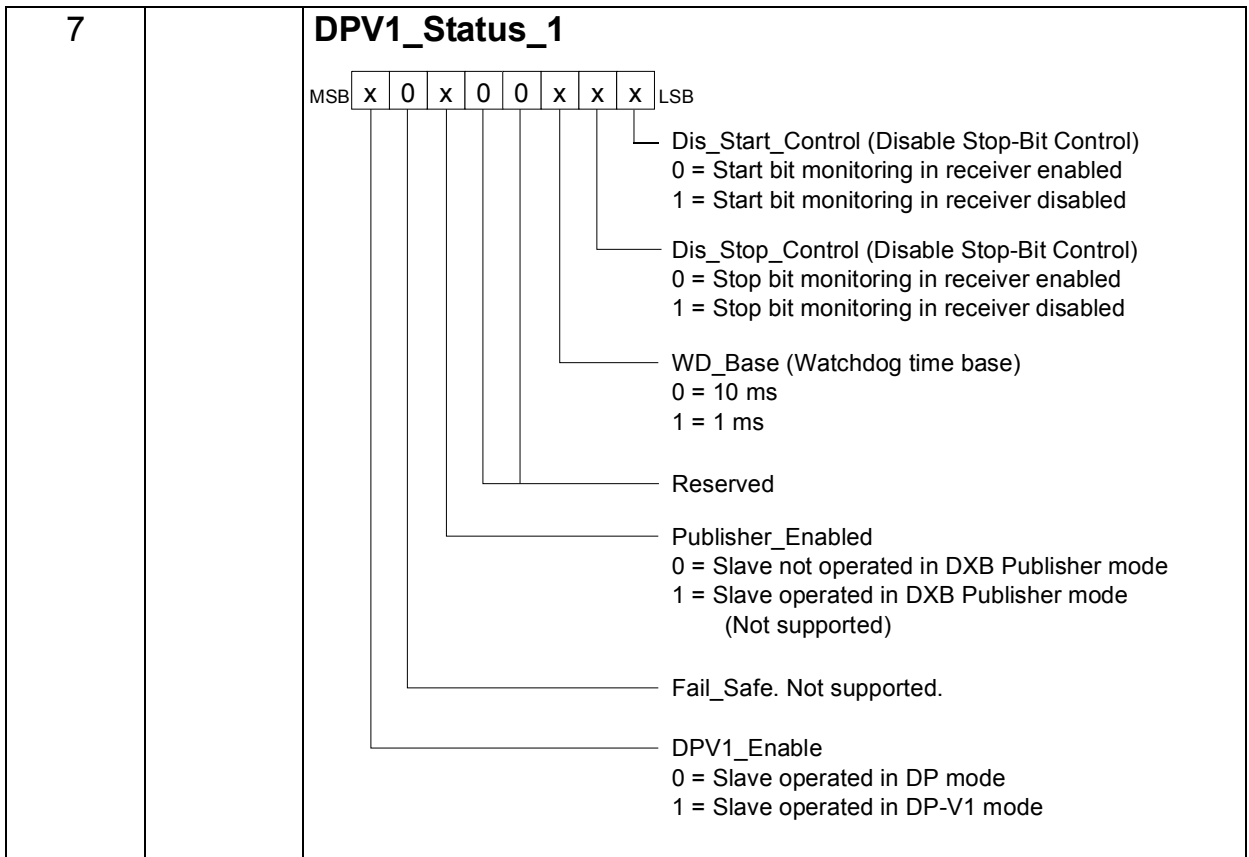

| | |
|----------|---|
| <p>8</p> | <p>DPV1_Status_2</p> <p>MSB X X X X X X 0 X LSB</p> <ul style="list-style-type: none"> Chk_Cfg_Mode 0 = Chk_Cfg according to EN 50170 (default state) 1 = User-specific evaluation of Chk_Cfg Reserved. To be parameterised with '0'. Enable_Update_Alarm 0 = Enable_Update_Alarm disabled 1 = Enable_Update_Alarm enabled (Not supported) Enable_Status_Alarm 0 = Enable_Status_Alarm disabled 1 = Enable_Status_Alarm enabled (Not supported) Enable_Manufacturer_Specific_Alarm 0 = Enable_Manufacturer_Specific_Alarm disabled 1 = Enable_Manufacturer_Specific_Alarm enabled (Not supported) Enable_Diagnostic_Alarm 0 = Enable_Diagnostic_Alarm disabled 1 = Enable_Diagnostic_Alarm enabled (Not supported) Enable_Process_Alarm 0 = Enable_Process_Alarm disabled 1 = Enable_Process_Alarm enabled (Not supported) Enable_Pull_Plug_Alarm 0 = Enable_Pull_Plug_Alarm disabled 1 = Enable_Pull_Plug_Alarm enabled (Not supported) |
| <p>9</p> | <p>DPV1_Status_3</p> <p>MSB 0 0 0 X X X X X LSB</p> <ul style="list-style-type: none"> Alarm_Mode. Limits the number of active alarms. 0 = 1 alarm of each type 1 = 2 alarms in total 2 = 4 alarms in total 3 = 8 alarms in total 4 = 12 alarms in total 5 = 16 alarms in total 6 = 24 alarms in total 7 = 32 alarms in total Prm_Structure 0 = Prm telegram according to EN 50170 1 = Prm telegram in structure form (DPV2 extension) (Not supported) IsoM_Req (Isochron Mode Request) 0 = Isochron Mode disabled 1 = Isochron Mode enabled (Not supported) Reserved. To be parameterised with '0'. |

| Prm_Data (Parameter Data Extended) Type: Octet String - Length: 23 | | |
|--|------------------|--|
| 10 | 10h (default) | <p>Header byte</p> <p>MSB 0 0 0 1 0 0 0 0 LSB</p> <p>Fail-safe mode. Defines the action taken when the PLC is switched from 'RUN' to 'STOP' mode. 00 = STOP (default) 01 = LAST SPEED 02 = USE FAIL-SAFE. The values of the PZDs are defined by bytes 11-30 in the Prm_Data telegram.</p> <p>Control zero mode. Defines the action taken if a PROFIBUS telegram containing only zeros is received. 00 = USE FRAME (default). Note that, with this setting, the drive might not be stopped (if it is running) since also bit 10 (Remote Command) in the control word is zero. However, the other PZD's may still be updated, but have the value zero. 01 = IGNORE</p> <p>Operation mode. Determines which control/status word and reference/actual values are used. 00 = PROFIDRIVE (i.e. Generic drive profile) 01 = VENDOR SPECIFIC (i.e. ABB Drives profile) (default). With this setting, <ul style="list-style-type: none"> Fail-safe mode 'STOP' equals 'LAST SPEED' the control word is forwarded unchanged to the drive if the drive has a parameter for selection of operation mode (i.e. communication profile), make sure that the operation modes of the RPBA-01 and the drive match. </p> <p>Reserved</p> |
| 11 - 12 | 0-65536 | Cut off time out in milliseconds. 0 = Cut off disabled. |
| 13 - 14 | 0-65536 | Fail-safe, PZD1 (CW) |
| 15 - 16 | 0-65536 | Fail-safe, PZD2 (REF) |
| 17 - 18 | 0-65536 | Fail-safe, PZD3 |
| 19 - 20 | 0-65536 | Fail-safe, PZD4 |
| 21 - 22 | 0-65536 | Fail-safe, PZD5 |
| 23 - 24 | 0-65536 | Fail-safe, PZD6 |
| 25 - 26 | 0-65536 | Fail-safe, PZD7 |

| | | |
|---------|---------|------------------|
| 27 - 28 | 0-65536 | Fail-safe, PZD8 |
| 29 - 30 | 0-65536 | Fail-safe, PZD9 |
| 31 - 32 | 0-65536 | Fail-safe, PZD10 |

The extended Parameter Data bytes are configured via the PROFIBUS network configuration tool. The functions are defined in the GSD file.

SAP 62 (Chk_Cfg)

SAP 62 selects the PPO type to be used. The table below gives the Hex values that must be sent to the drive to select the PPO type.

| Cfg_Data (Configuration Data) | | | | |
|--------------------------------------|------------|------------------------------|--------------------|---------------------|
| Type: Octet String - Length: 4 to 28 | | | | |
| PPO Type | Hex Values | PROFIdrive parameter enabled | *PKW size in bytes | **PZD size in bytes |
| 1 | F3 F1 | Acyclic Parameter Read | 8 | 4 |
| 2 | F3 F5 | Acyclic Parameter Read | 8 | 12 |
| 3 | F1 | Acyclic Parameter Read/Write | 0 | 4 |
| 4 | F5 | Acyclic Parameter Read/Write | 0 | 12 |
| 5 | F3 F9 | Acyclic Parameter Read | 8 | 20 |
| 6 | F9 | Acyclic Parameter Read/Write | 0 | 20 |

*PKW: "Parameter-Kennung-Wert" (Parameter ID Value)

**PZD: "Prozeßdaten" (Process data)

With PPO1, PPO2 and PPO5, reading/writing parameters is only possible cyclically through the Parameter Identification (PKW) channel. With PPO3, PPO4 or PPO6, acyclic parameter reading/writing is available via the DP-V1 parameter read/write service.

The PPO type can be changed during runtime. However, the RPBA-01 will go offline while the configuration is being updated.

SAP 60 (Slave_Diag)

This SAP gives diagnostic information on the slave station.

| Diag_Data (Diagnostic Data) | |
|--|---|
| Type: Octet String - Length: 6 (Standard) + 2 (Extended Diagnosis) | |
| Byte | Description |
| 0 | <p>Station_Status_1</p> <p>MSB x x x x x x x x LSB</p> <ul style="list-style-type: none"> Diag.Station_Non_Existent (Set by Master, reset by Slave) Slave not found Diag.Station_Not_Ready (Set by Slave) Slave not ready for data exchange Diag.Cfg_Fault (Set by Slave) Received configuration data does not match original config. data Diag.Ext_Diag (Set by Slave) Diagnostic entry present in slave-specific diagnostic area Diag.Not_Supported (Set by Slave) Service not supported by slave Diag.Invalid_Slave_Response (Set by Master, reset by Slave) Invalid response by slave Diag.Prm_Fault (Set by Slave) Invalid parameter or parameter value Diag.Master_Lock (Set by Master, reset by Slave) Slave is parameterised by another master |
| 1 | <p>Station_Status_2</p> <p>MSB x 0 x x x 1 x x LSB</p> <ul style="list-style-type: none"> Diag.Prm_Req (Set by Slave) Slave requires re-configuration and re-parameterisation Diag.Stat_Diag (Set by Slave) Static diagnosis. Slave (temporarily) unable to provide valid data Always set to 1 by slave Diag.WD_On (Set by Slave) Watchdog on Diag.Freeze_Mode (Set by Slave) Freeze command received by slave Diag.Sync_Mode (Set by Slave) Sync command received by slave Reserved Diag.Deactivated (Set by Master, reset by Slave) Slave is inactive |

| Diag_Data (Diagnostic Data) Type: Octet String - Length: 6 (Standard) + 2 (Extended Diagnosis) | |
|--|---|
| Byte | Description |
| 2 | Station_Status_3 |
| 3 | Diag.Master_Add The address of the master that parameterised this slave |
| 4 - 5 | Ident_Number (for RPBA-01: 0812h) |
| 6 | Header Byte |
| 7 | Status Type = Status Message (0x81) |
| 8 | Slot Number (0x00) |
| 9 | Specifier (0x00) |
| 10 | Communication Diagnostic |

SAP 0 (Data_Exchange)

Allows the master to send output data to a slave station and to simultaneously request input data from the same station.

Outp_Data (Output Data)

Type: Octet String - Length: 4 to 28 (depending on the selected PPO Type)

Inp_Data (Input Data)

Type: Octet String - Length: 4 to 28 (depending on the selected PPO Type)

PPO message types

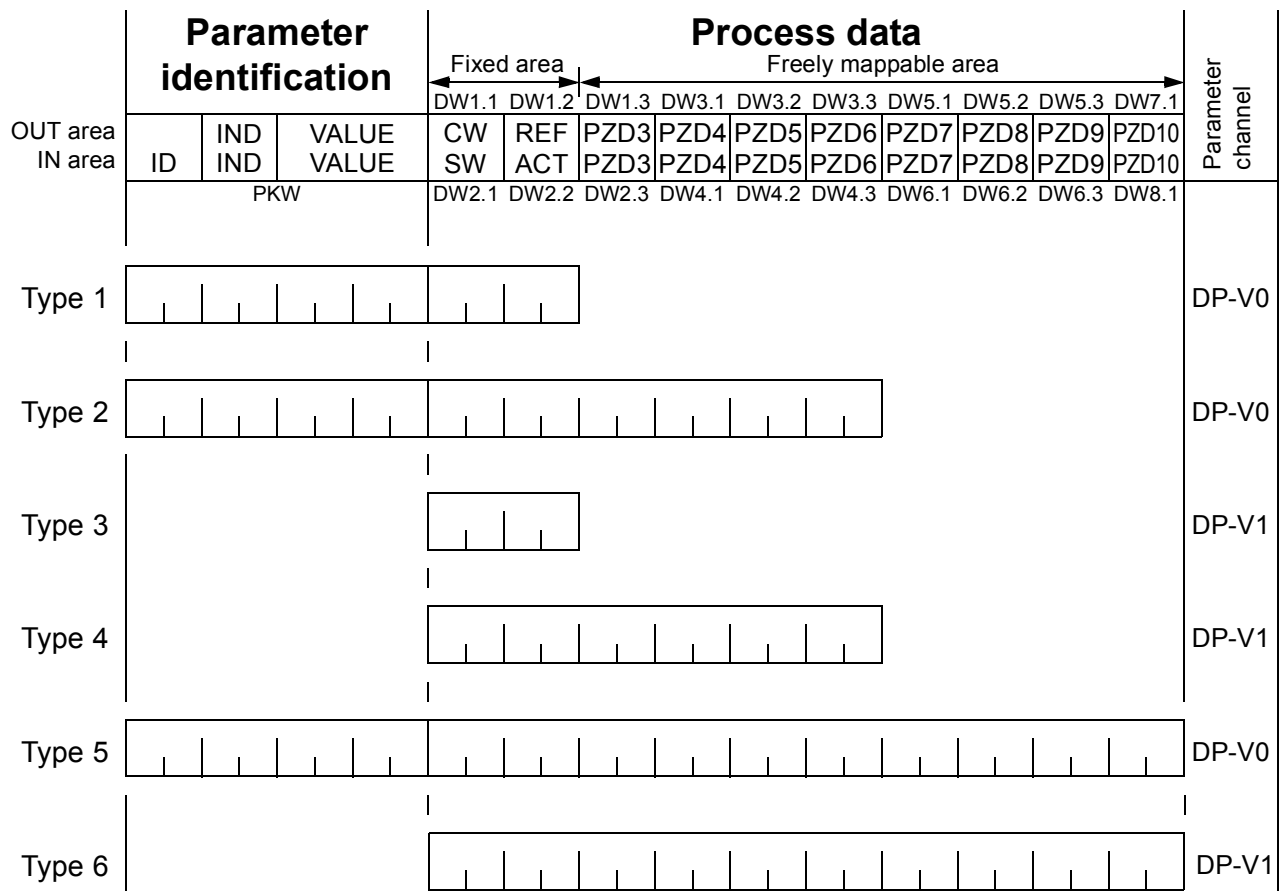

OUT area – Data sent from Master to Slave (control data)

IN area – Data sent from Slave to Master (actual data)

Parameter Identification:

ID – Parameter Identification

IND – Index for Arrays

VALUE – Parameter Value (Max. 4 bytes)

PKW – Parameter ID/Value

Process Data:

CW – Control Word (see Table 11.)

SW – Status Word (see Table 12.)

REF – Reference

ACT – Actual Value

PZD – Process Data (application-specific)

DW – Data Word

Figure 10. PPO message types

The Control Word and the Status Word

The Control Word (PROFIBUS Parameter 967) is the principal means for controlling the drive from a fieldbus system. It is sent by the fieldbus master station to the drive, the adapter module acting as a gateway. The drive switches between its states according to the bit-coded instructions on the Control Word, and returns status information to the master in the Status Word (PROFIBUS Parameter 968).

The contents of the Control Word and the Status Word are detailed in Tables 11 and 12 respectively; see the drive documentation for information on the drive-specific bits. The drive states are presented in the PROFIBUS State Machine (Figure 13).

References

References are 16-bit words containing a sign bit and a 15-bit integer. A negative reference (indicating reversed direction of rotation) is formed by calculating the two's complement from the corresponding positive reference.

ABB drives can receive control information from multiple sources including analogue and digital inputs, the drive control panel and a communication module (e.g. RPBA-01). In order to have the drive controlled through PROFIBUS, the communication module must be defined as the source for control information, e.g. Reference.

In the Vendor Specific mode, the scaling of the integer received from the master as Reference is drive-specific. See its programming manual for available control source selections and Reference scaling factors.

In PROFIdrive mode, the speed reference (REF) in hexadecimal (0 ... 4000h) corresponds to 0 ... 'motor nominal speed'.

Actual Values

Actual Values are 16-bit words containing information on the operation of the drive. The functions to be monitored are selected by a drive parameter. The scaling of the integers sent to the

master as Actual Values depends on the selected function, refer to the drive documentation.

In PROFIdrive mode, the actual speed (ACT) in hexadecimal (0...4000h) corresponds to 0...'motor nominal speed'.

Table 11. The Control Word (PROFIBUS Parameter 967). The upper case boldface text refers to the states shown in Figure 13.

| Bit | Name | Value | Proceed to STATE/Description |
|-----|------------------|-------|--|
| 0 | ON | 1 | Proceed to READY TO OPERATE |
| | OFF1 | 0 | Emergency OFF, stop by the selected deceleration ramp. Proceed to OFF1 ACTIVE ; proceed further to READY TO SWITCH ON unless other interlocks (OFF2, OFF3) are active |
| 1 | OFF2 | 1 | Continue operation (OFF2 inactive) |
| | | 0 | Emergency OFF, coast to stop. Proceed to OFF2 ACTIVE ; proceed further to SWITCH-ON INHIBIT |
| 2 | OFF3 | 1 | Continue operation (OFF3 inactive) |
| | | 0 | Emergency stop, stop according to fastest possible deceleration mode. Proceed to OFF3 ACTIVE ; proceed further to SWITCH-ON INHIBIT . Warning: Ensure motor and driven machine can be stopped using this stop mode. |
| 3 | OPERATION_ENABLE | 1 | Proceed to ENABLE OPERATION |
| | | 0 | Inhibit operation. Proceed to OPERATION INHIBIT |
| 4 | RAMP_OUT_ZERO | 1 | Normal operation. Proceed to RAMP FUNCTION GENERATOR: ENABLE OUTPUT |
| | | 0 | Stop according to selected stop type |
| 5 | RAMP_HOLD | 1 | Normal operation. Proceed to RAMP FUNCTION GENERATOR: ENABLE ACCELERATOR |
| | | 0 | Halt ramping (Ramp Function Generator output held) |

| Bit | Name | Value | Proceed to STATE/Description |
|-----|--------------|--|---|
| 6 | RAMP_IN_ZERO | 1 | Normal operation. Proceed to OPERATING |
| | | 0 | Force Ramp Function Generator input to zero |
| | | Note: The function of this bit may depend on the ramp parameter settings of the drive. See the drive documentation. | |
| 7 | RESET | 0 ⇒ 1 | Fault reset if an active fault exists. Proceed to SWITCH-ON INHIBIT. |
| | | 0 | (Continue normal operation) |
| 8 | INCHING_1 | | Inching 1. (See the drive documentation for information) |
| 9 | INCHING_2 | | Inching 2. (See the drive documentation for information) |
| 10 | REMOTE_CMD | 1 | Fieldbus control enabled |
| | | 0 | Control Word <> 0 or Reference <> 0: Retain last Control Word and Reference Control Word = 0 and Reference = 0: Fieldbus control enabled |
| 11 | | | Vendor-specific bit as defined by PROFIdrive parameter 933. |
| 12 | | | Vendor-specific bit as defined by PROFIdrive parameter 934. |
| 13 | | | Vendor-specific bit as defined by PROFIdrive parameter 935. |
| 14 | | | Vendor-specific bit as defined by PROFIdrive parameter 936. |
| 15 | | | Vendor-specific bit as defined by PROFIdrive parameter 937. |

Table 12. The Status Word (PROFIBUS Parameter 968). The upper case boldface text refers to the states shown in Figure 13.

| Bit | Name | Value | STATE/Description |
|-----|--------------|-------|---|
| 0 | RDY_ON | 1 | READY TO SWITCH ON |
| | | 0 | NOT READY TO SWITCH ON |
| 1 | RDY_RUN | 1 | READY TO OPERATE |
| | | 0 | OFF1 ACTIVE |
| 2 | RDY_REF | 1 | ENABLE OPERATION |
| | | 0 | DISABLE OPERATION |
| 3 | TRIPPED | 1 | FAULT |
| | | 0 | No fault |
| 4 | OFF_2_STA | 1 | OFF2 inactive |
| | | 0 | OFF2 ACTIVE |
| 5 | OFF_3_STA | 1 | OFF3 inactive |
| | | 0 | OFF3 ACTIVE |
| 6 | SWC_ON_INHIB | 1 | SWITCH-ON INHIBIT ACTIVE |
| | | 0 | SWITCH-ON INHIBIT NOT ACTIVE |
| 7 | ALARM | 1 | Warning/Alarm |
| | | 0 | No Warning/Alarm |
| 8 | AT_SETPOINT | 1 | OPERATING. Actual value equals reference value (i.e. is within tolerance limits) |
| | | 0 | Actual value differs from reference value (= is outside tolerance limits) |
| 9 | REMOTE | 1 | Drive control location: REMOTE |
| | | 0 | Drive control location: LOCAL |
| 10 | ABOVE_LIMIT | 1 | Actual frequency or speed value equals or is greater than supervision limit. |
| | | 0 | Actual frequency or speed value is within supervision limit. |

| Bit | Name | Value | STATE/Description |
|------------|-------------|--------------|--|
| 11 | | | Vendor-specific bit as defined by PROFIdrive parameter 939. (See the drive documentation.) |
| 12 | | | Vendor-specific bit as defined by PROFIdrive parameter 940. (See the drive documentation.) |
| 13 | | | Vendor-specific bit as defined by PROFIdrive parameter 941. (See the drive documentation.) |
| 14 | | | Vendor-specific bit as defined by PROFIdrive parameter 942. (See the drive documentation.) |
| 15 | | | Vendor-specific bit as defined by PROFIdrive parameter 943. (See the drive documentation.) |

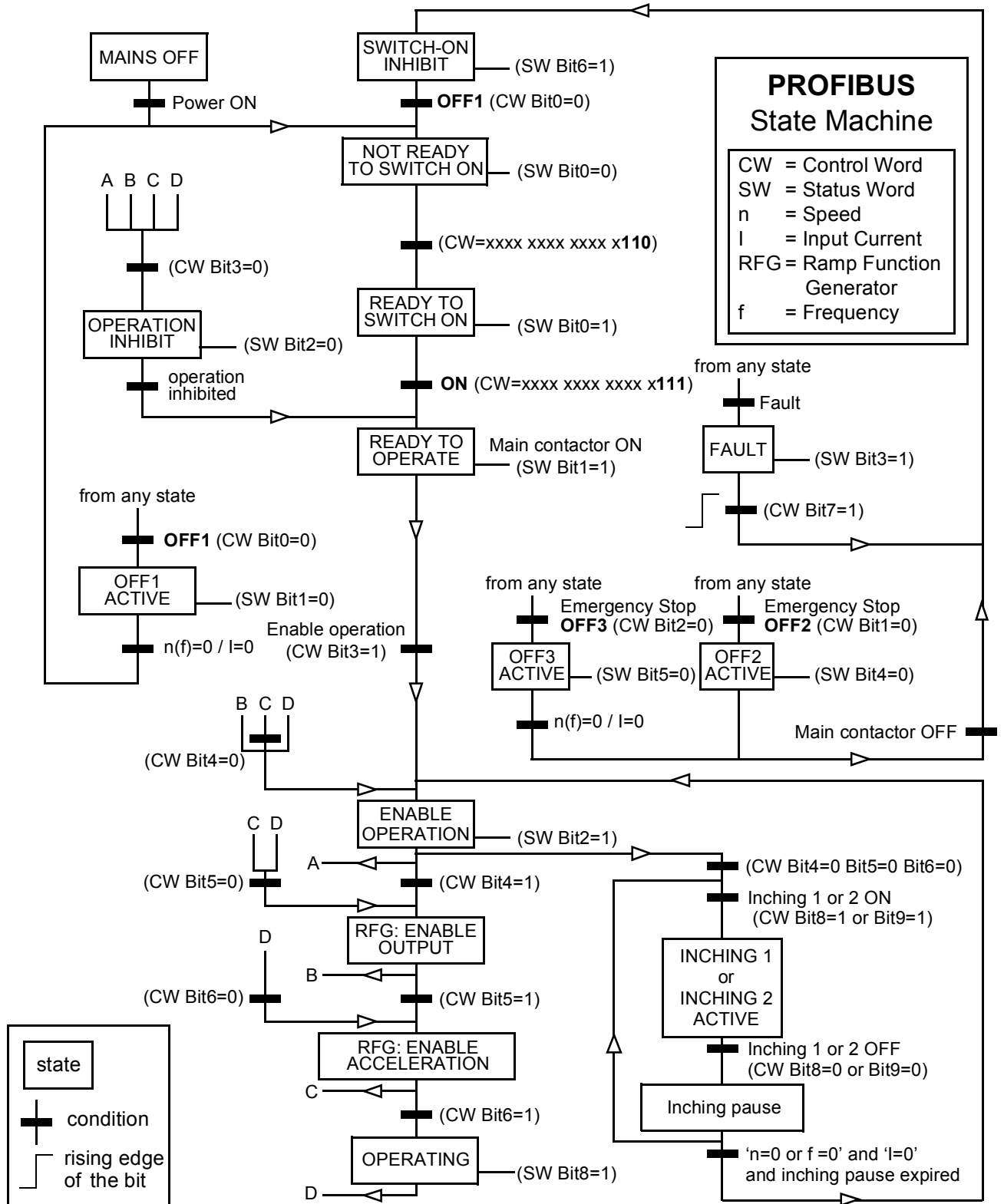
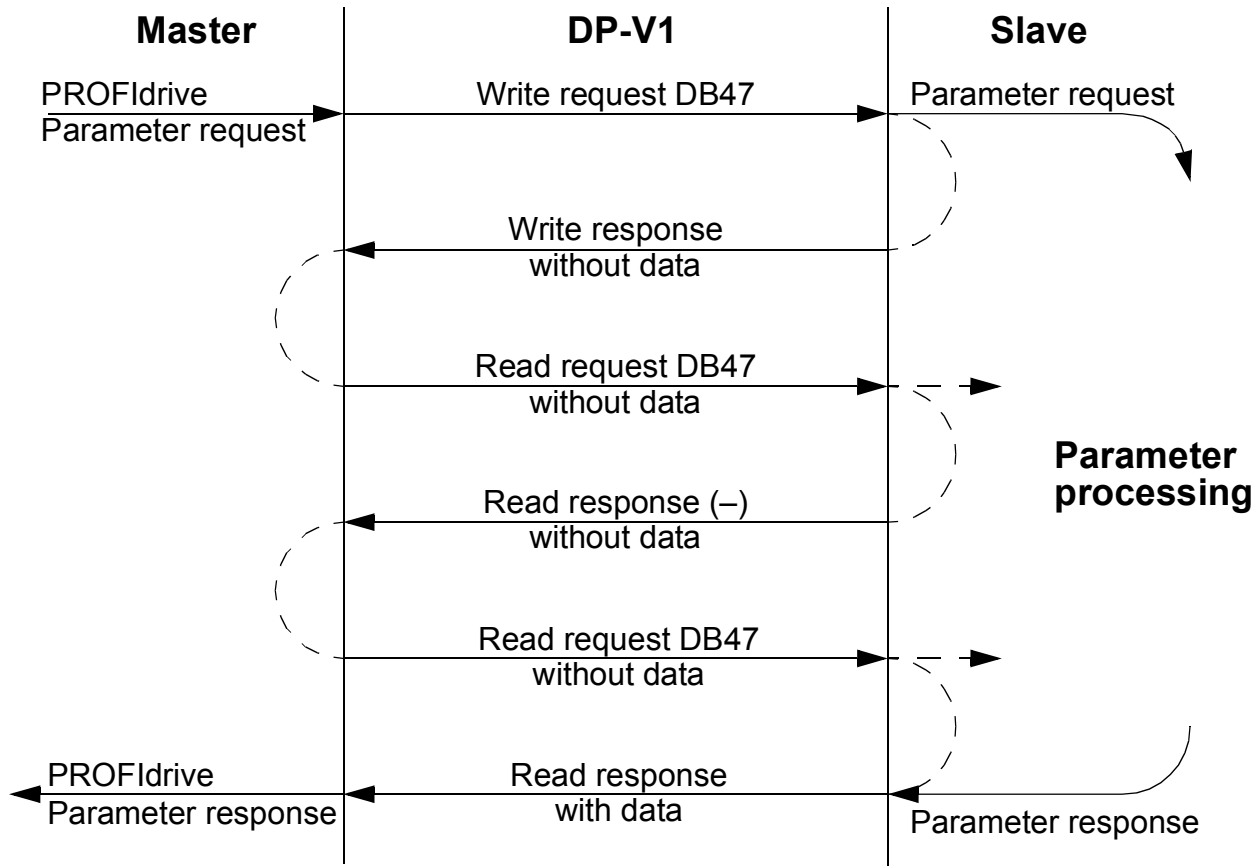

Figure 13. The PROFIBUS state machine

DP-V1 read/write request sequence

A read/write service on a drive parameter is illustrated below.



The messaging employs DP-V1 data units. The PROFIdrive parameter request is contained within the DP-V1 request as data. Likewise, the DP-V1 response contains the PROFIdrive parameter response as data.

A write request (Function number 5Fh – see Table 15 below) is first sent containing the parameter request.

If the write request is valid, the RPBA-01 acknowledges it with DP-V1 write response code 5Fh with no data. The master will then send a read request. If the RPBA-01 is still busy performing the internal parameter request, it will return a negative response with the DP-V1 error code B5h (State conflict). In this case, the read

request will be repeated by the master until the RPBA-01 has the PROFIdrive response data ready.

If the write request is invalid, a negative response is returned with a DP-V1 error code (see Table 17).

PROFIBUS SD2 telegram for SAP 51

The Read/Write service uses a variable-length PROFIBUS SD2 telegram shown below.

| DP header | | | | | | | | | DP trailer | | |
|-----------|----|-----|-----|----|----|----|-----|-----|------------|-----|-----|
| SD | LE | LEr | SD | DA | SA | FC | DSA | SSA | DU | FCS | ED |
| 68h | x | x | 68h | xx | xx | x | xx | xx | x... | xx | 16h |

SD = Start Delimiter
 LE = Length
 LEr = Length repeated
 DA = Destination Address
 SA = Source Address
 FC = Function Code
 DSAP = Destination Service Access Point
 SSAP = Source Service Access Point
 DU = Data Unit for DP services
 FCS = Frame Checking Sequence
 ED = End Delimiter

| Data unit | | | | | |
|------------------------|-----|-----|-----|--|------|
| DP-V1 Command/Response | | | | PROFIdrive V3 Parameter Channel | |
| DU0 | DU1 | DU2 | DU3 | Request/Response header (see Table 18/19 below) | Data |

| Byte | Meaning | Value |
|-----------------------|-----------------|------------------------------|
| DU0 | Function number | See Table 15 below |
| DU1 | Slot number | 1 = Drive parameter access |
| DU2 | Index | 47 (0x2F) |
| DU3 | Data length | (Depends on type of message) |
| DU4...DU _n | PROFIdrive data | |

Figure 14. PROFIBUS SD2 telegram

Table 15. DP-V1 function numbers

| Value | Meaning |
|--------------|----------------------------------|
| 0x48 | Idle REQ, RES |
| 0x51 | Data transport REQ, RES |
| 0x56 | Resource manager REQ |
| 0x57 | Initiate REQ, RES |
| 0x58 | Abort REQ |
| 0x5C | Alarm REQ, RES |
| 0x5E | Read REQ, RES |
| 0x5F | Write REQ, RES |
| 0xD1 | Data transport negative response |
| 0xD7 | Initiate negative response |
| 0xDC | Alarm negative response |
| 0xDE | Read negative response |
| 0xDF | Write negative response |

Table 16. DP-V1 error response

| Byte | Meaning and value |
|-------------|--|
| DU0 | Function number = 0xDF (Error Write) = 0xDE (Error Read) |
| DU1 | Error_Decompose = 0x80 (DP-V1) PROFIdrive: Always 128 (DP-V1 codes) |
| DU2 | Error_Code_1: Error class/error code (see Table 17 below) |
| DU3 | Error_Code_2: Always 0 |

Table 17. DP-V1 error response: Error codes

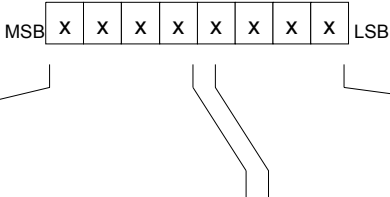

| Error class | Meaning | Error code |
|-------------|---------------|--|
| 0 ... 9 | (Reserved) | |
| 10 (0x0A) | Application | 0 = Read error 1 = Write error 2 = Module failure 3 ... 7 = Reserved 8 = Version conflict 9 = Feature not supported 10 ... 15 = User-specific |
| 11 (0x0B) | Access | 0 = Invalid index 1 = Write length error 2 = Invalid slot 3 = Type conflict 4 = Invalid area 5 = State conflict 6 = Access denied 7 = Invalid range 8 = Invalid parameter 9 = Invalid type 10 ... 15 = User-specific |
| 12 (0x0C) | Resource | 0 = Read constraint conflict 1 = Write constraint conflict 2 = Resource busy 3 = Resource unavailable 4 ... 7 = Reserved 8 ... 15 = User-specific |
| 13 ... 15 | User-specific | |

Table 18. PROFIdrive Request header

| Field(s) | Description | Range | Byte/ Word |
|--|--|---|------------------|
| Request Reference | Unique identification set by the master. Changed for each new request. | 1 ... 255 | Byte |
| Request ID | Request type for the issued block. | Request Parameter (01h) Change Parameter (02h) | Byte |
| Axis | To be set to 0 or 1. | 0 ... 255 | Byte |
| No. of Parameters | Number of parameters that are present in the request. | 1 ... 37 | Byte |
| Attribute | Type of object being accessed. Note: "Text" is not supported. | Value (10h) Description (20h) Text (30h) | Byte |
| No. of Elements | Number of array elements accessed or length of string accessed. Set to 0 if non-array parameters are used. | 0, 1 ... 234 | Byte |
| Parameter Index | Address of the parameter that is being accessed. "0" is allowed by RPBA-01. | 1 ... 65535 | Word |
| Subindex | Addresses the first array element of the parameter or the beginning of a string access or the text array, or the description element that is being accessed. | 0 ... 65535 | Word |
| Format* | See Table 20. | See Table 20 | Byte |
| Number of Values* | Number of values following. | 0 ... 234 | Byte |
| Values* | The values of the request. In case of odd number of bytes, a zero byte is appended to ensure the word structure of the telegram. | – | See Format field |
| *Only if Request ID is 02h (Change Parameter). The Format, Number of Values and Values fields are repeated for other parameters. | | | |

Table 19. PROFIdrive Response header

| Field(s) | Description | Range |
|---|--|--|
| Response Reference | Mirrored from the request. | 1 ... 255 |
| Response ID | Response from the slave. In case any requested services fail, a “not acknowledged” (NAK) response will be indicated. | Request Param OK (01h) Request Param NAK (81h) Change Param OK (02h) Change Param NAK (82h) |
| Axis | To be set to 1. | 0 ... 255 |
| No. of Parameters | Number of parameters that are present in the response. | 1 ... 37 |
| Format* | See Table 20. | See Table 20 |
| Number of Values* | Number of values following. | 0 ... 234 |
| Values* | The values of the request. In case of odd number of bytes, a zero byte is appended to ensure the word structure of the telegram. | – |
| *Only if Response ID is 01h (Request Parameter OK). The Format, Number of Values and Values fields are repeated for other parameters. | | |

Table 20. Data types for Format field

| Code | Type |
|---------------|---------------------|
| 0x00 | (Reserved) |
| 0x01 ... 0x36 | Standard data types |
| 0x37 ... 0x3F | (Reserved) |
| 0x40 | Zero |
| 0x41 | Byte |
| 0x42 | Word |
| 0x43 | Double word |
| 0x44 | Error |
| 0x45 ... 0xFF | (Reserved) |

Table 21. PROFIdrive Parameter Request error codes

| Error # | Meaning | Used at |
|----------------|--|--|
| 00h | Impermissible parameter number | Access to unavailable parameter |
| 01h | Parameter value cannot be changed | Change access to a parameter value that cannot be changed |
| 02h | Low or high limit exceeded | Change access with value outside the limits |
| 03h | Invalid subindex | Access to unavailable subindex |
| 04h | No array | Access with subindex to non-indexed parameter |
| 05h | Incorrect data type | Change access with value that does not match the data type of the parameter |
| 06h | Setting not permitted (can only be reset) | Change access with value unequal to 0 when this is not permitted |
| 07h | Description element cannot be changed | Change access to a description element that cannot be changed |
| 09h | No description data available | Access to unavailable description (parameter value is available) |
| 0Bh | No operation priority | Change access rights without rights to change parameters |
| 0Fh | No text array available | Access to text array that is not available (parameter value is available) |
| 11h | Request cannot be executed because of operating mode | Access is temporarily not possible for reasons that are not specified in detail |
| 14h | Value impermissible | Change access with a value that is within limits but is not permissible for other long-term reasons (parameter with defined single values) |
| 15h | Response too long | The length of the current response exceeds the maximum transmittable length |

| | | |
|-------------|---------------------------------|---|
| 16h | Parameter address impermissible | Illegal value or value that is not supported for the attribute, number of elements, parameter number or sub-index, or a combination |
| 17h | Illegal format | Write request: Illegal format or format of parameter data that is not supported |
| 18h | Number of values inconsistent | Write request: Number of values of parameter data does not match number of elements at the parameter address |
| 65h ... FF | Manufacturer-specific | – |
| 65h | Vendor-specific error | Vendor-specific error |
| 66h | Request not supported | Request not supported |
| 67h | Communication error | Request cannot be completed because of communication error |
| 68h ... 6Dh | Manufacturer-specific | – |
| 6Eh | Non-volatile error | Failure during write to non-volatile memory |
| 6Fh | Time-out error | Request aborted because of timeout |
| 70h ... 77h | Manufacturer-specific | – |
| 78h | PZD map failure | Parameter cannot be mapped to PZD (size mismatch or non-existent) |
| 79h | PZD memory failure | Parameter cannot be mapped to PZD (out of memory) |
| 7Ah | Multiple PZD map | Parameter cannot be mapped to PZD (multiple PZD write) |
| 7Bh ... 81h | Manufacturer-specific | – |
| 82h | Control word bit map | Cannot map Control word bit (parameter 933...937, e.g. double mapping of bits) |

| | | |
|----------------|-----------------------|---|
| 83h ... 8Bh | Manufacturer-specific | – |
| 8Ch | Set torque mode error | Cannot change mode to TORQUE (frequency is used) |
| 90h | Illegal Request ID | The request ID of the response is illegal |
| 8Dh ... FFh | Manufacturer-specific | – |

Parameter data transfer examples

The following examples show how parameter data is transferred using the DP-V1 mechanisms READ and WRITE.

Note: Only the “Data unit” part of the SD2 telegram is presented in the examples. See Figure 14 on page 80.

Example 1a: Reading a drive parameter

To determine the parameter number and subindex for drive parameter reading, multiply the parameter number by one hundred and then convert it to hexadecimal. The low byte is the subindex (IND), and the high byte is the parameter index (PNU). For example, drive parameter number 12.04 corresponds to $12.04 \times 100 = 1204 = 4B4h$.

DP-V1 Write request (Read parameter value):

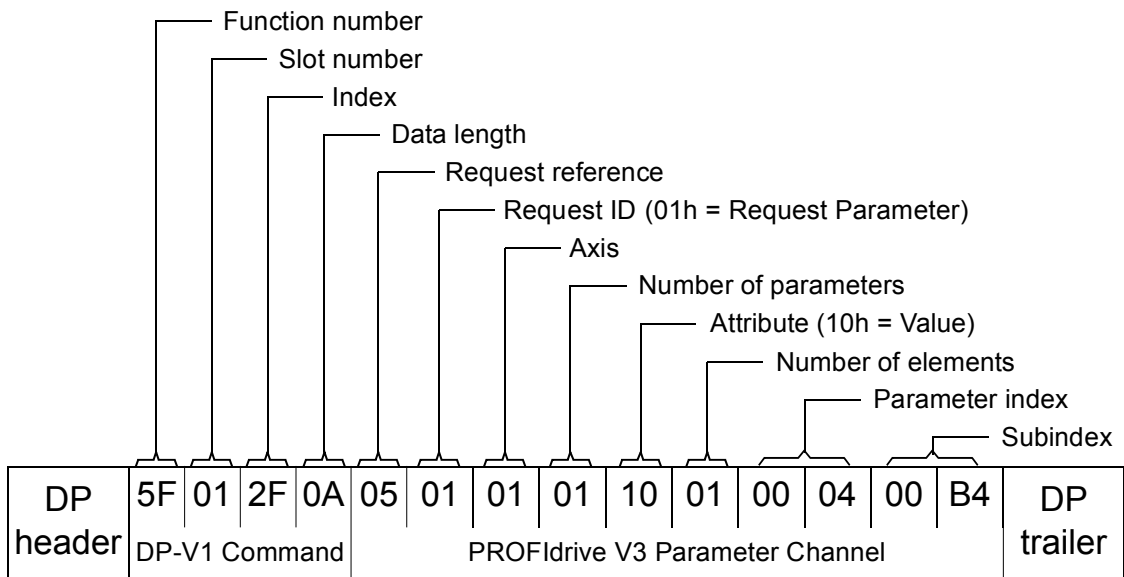

Positive Read response to DP-V1 Read request:

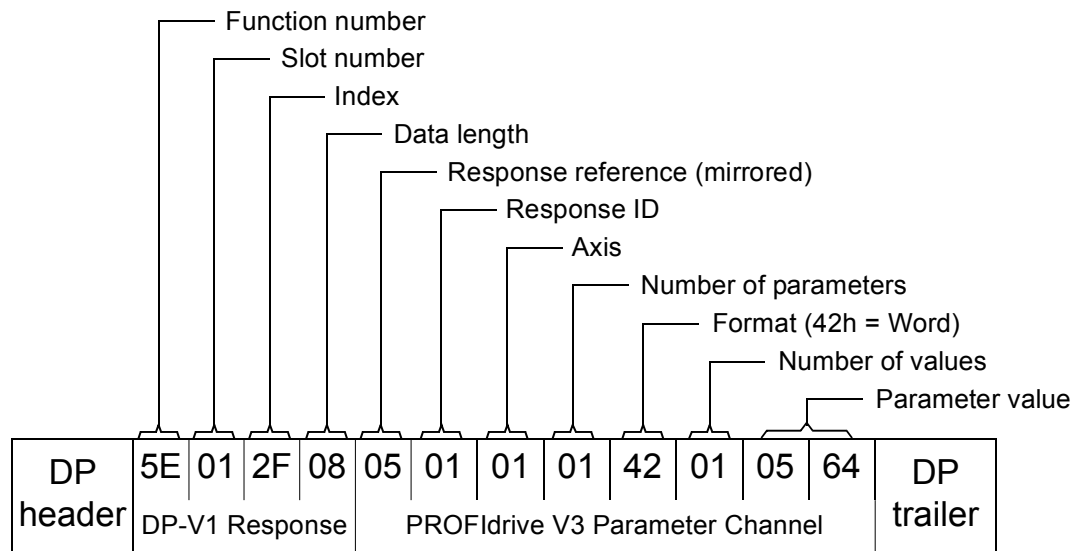

Negative response to PROFdrive Read request:

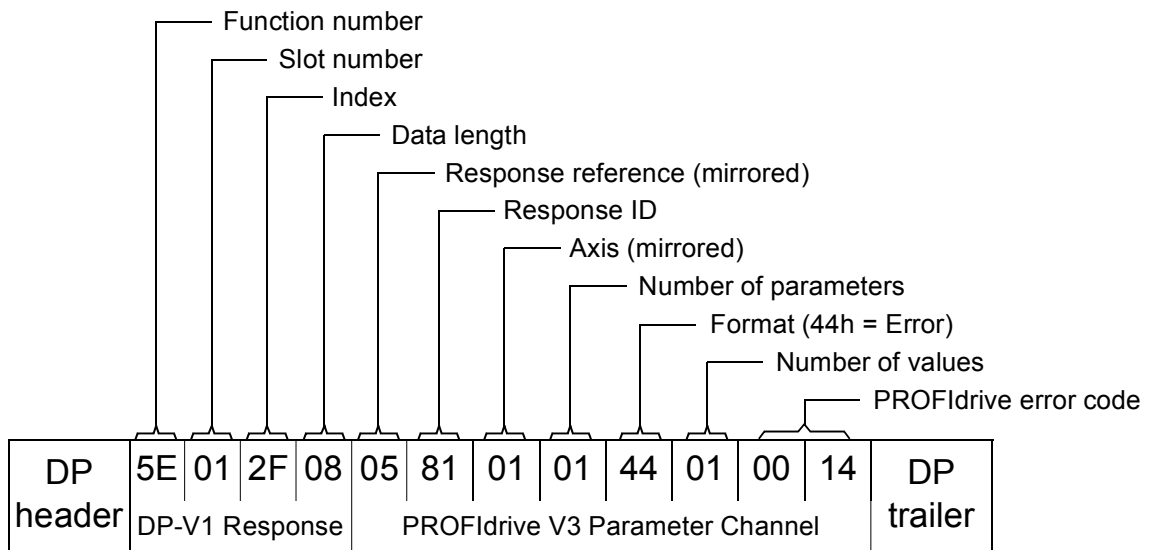

Example 1b: Reading 3 drive parameters

In this example, three parameters (12.04, 12.05 and 12.06) are read using one telegram.

DP-V1 Write request (Read parameter value):

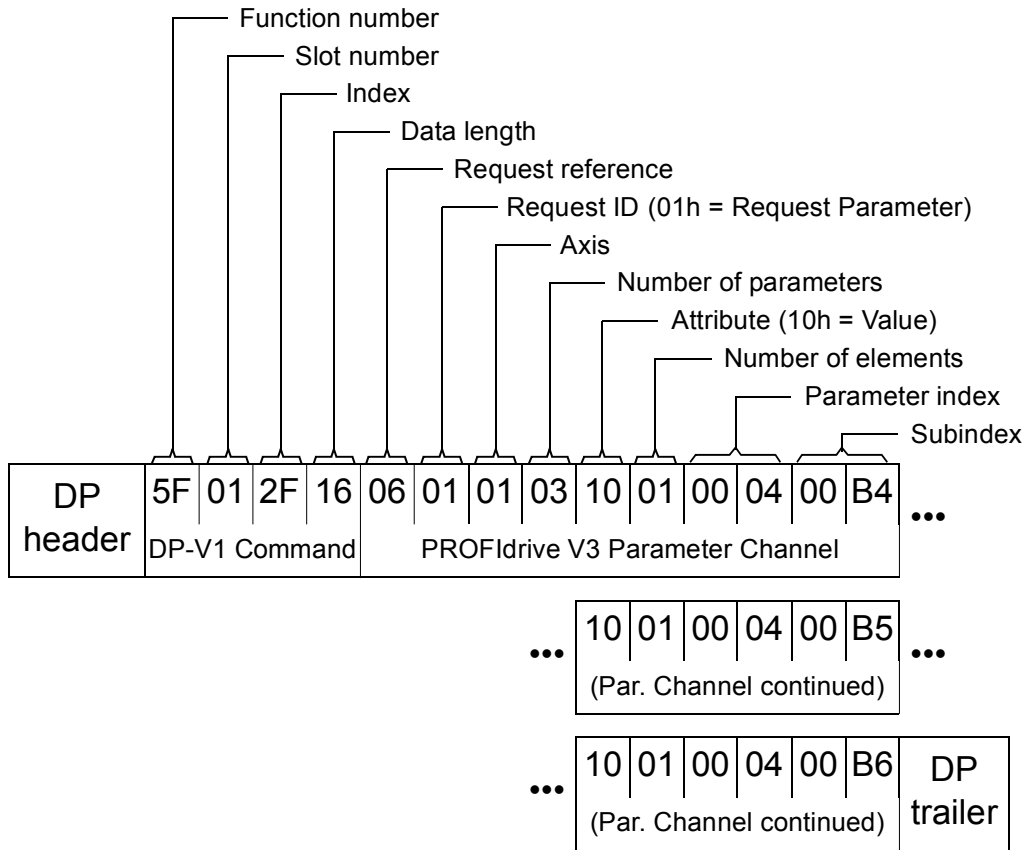

Positive Read response to DP-V1 Read request:

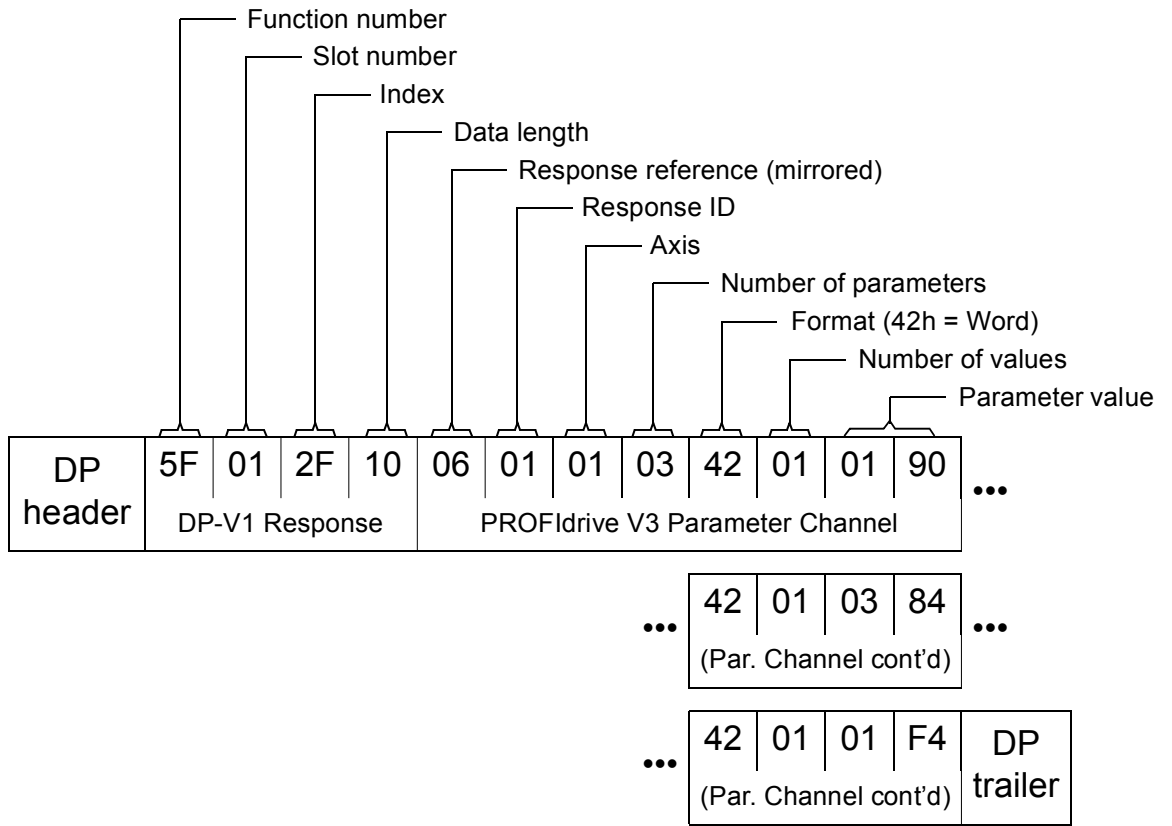

The values 190h (400), 384h (900) and 1F4h (500) are returned.

Example 2a: Writing a drive parameter

To determine the parameter number and subindex for drive parameter reading, multiply the parameter number by one hundred and then convert it to hexadecimal. The low byte is the subindex (IND), and the high byte is the parameter index (PNU). For example, drive parameter number 12.02 corresponds to $12.02 \times 100 = 1202 = 4B2h$.

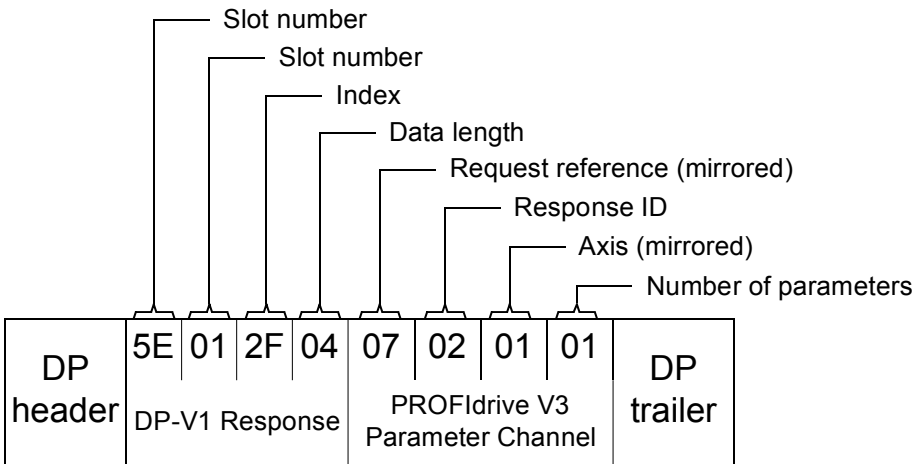
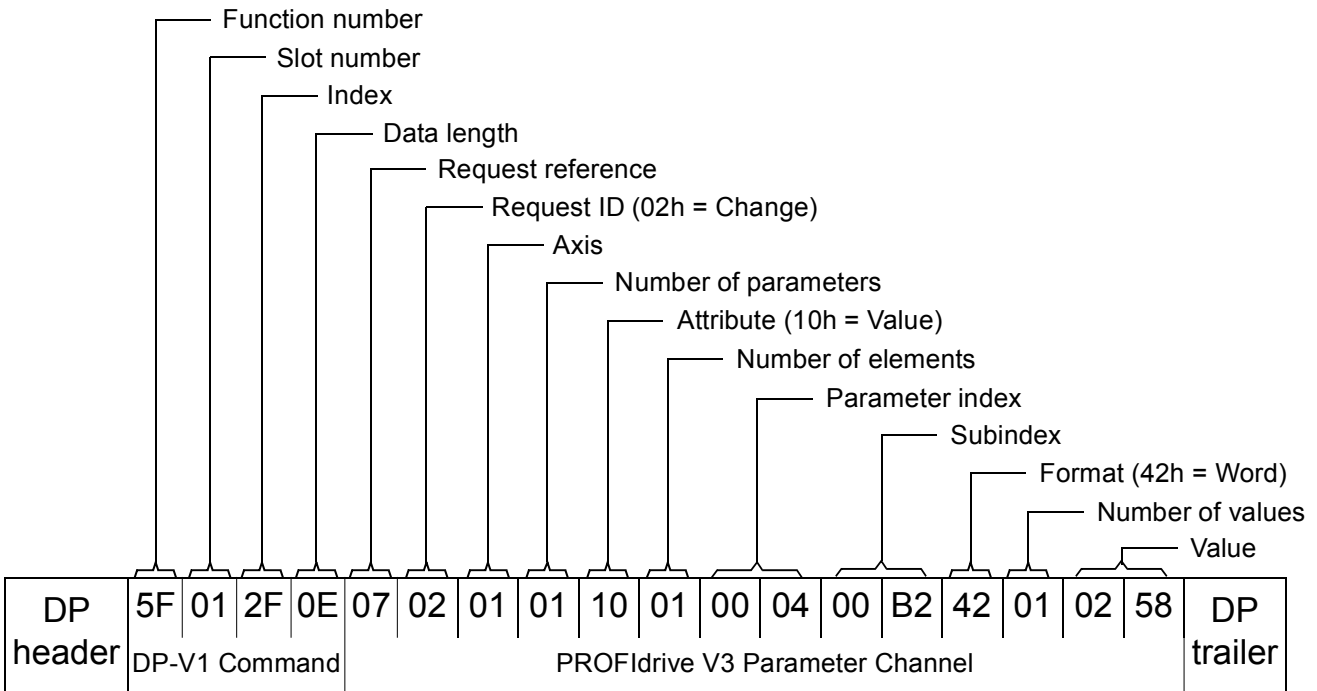

Example 2b: Writing 2 drive parameters

In this example, the values 300 (12Ch) and 500 (1F4h) are written to drive parameters 12.02 (4B2h) and 12.03 (4B3h) respectively using one telegram.

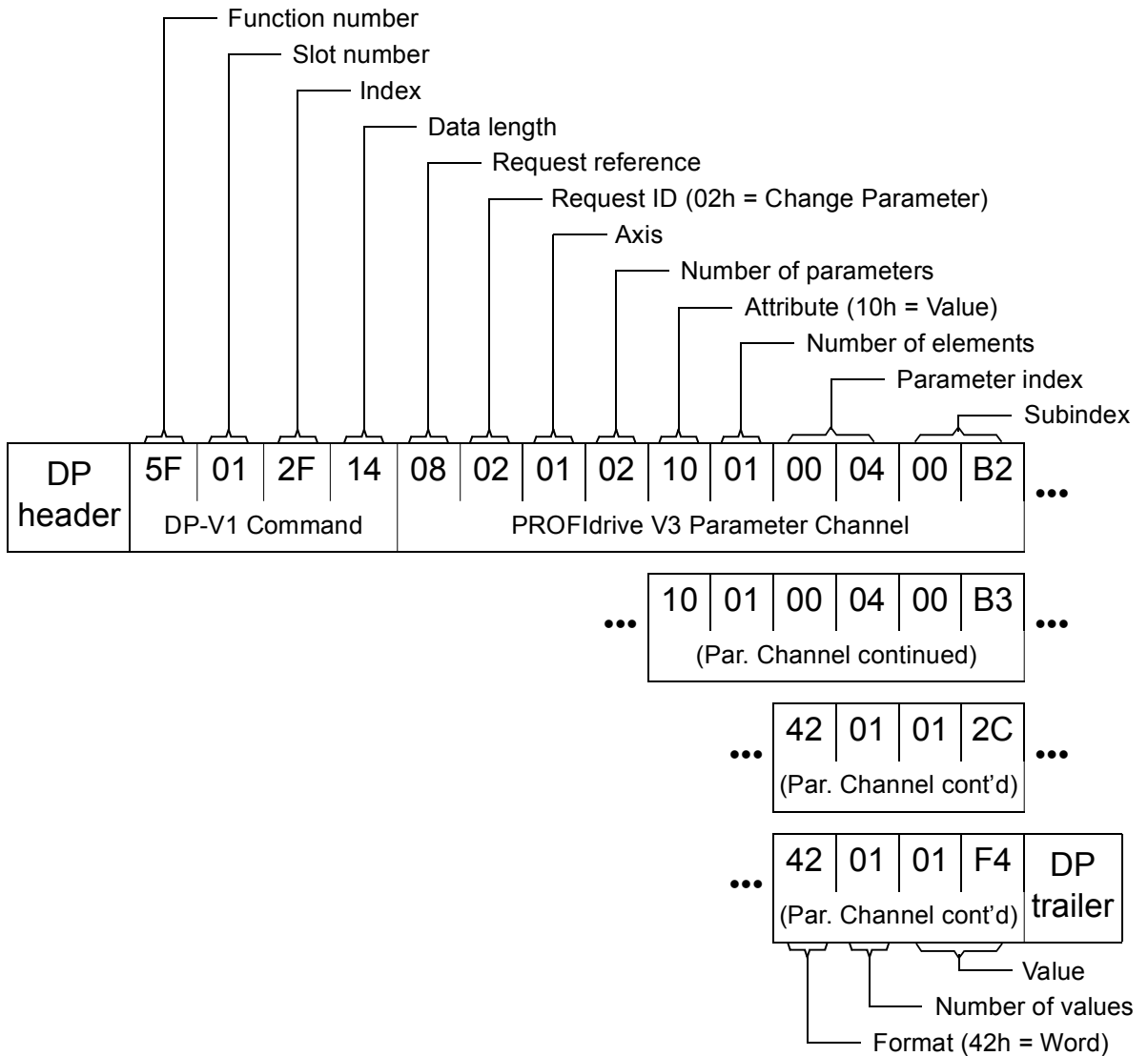

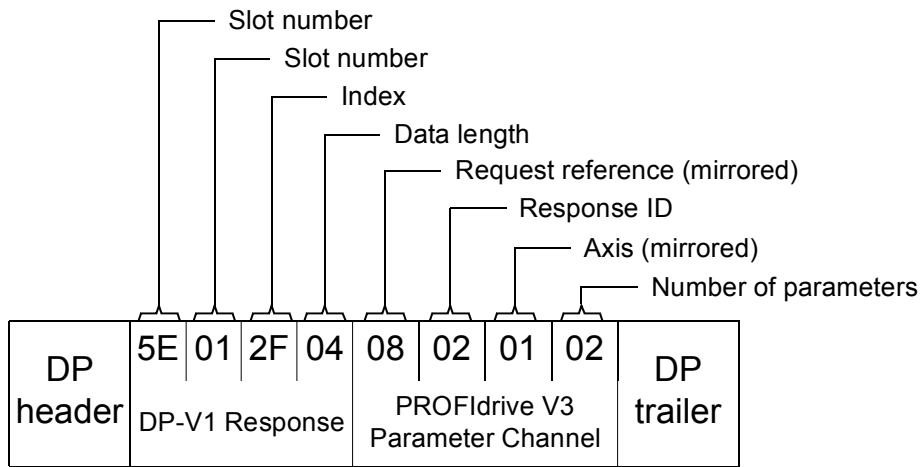

Example 3: Reading a PROFdrive parameter

In this example, PROFIBUS parameter No. 918 (396h) is used to read the station number of the slave.

DP-V1 Write request (Reading a PROFdrive parameter):

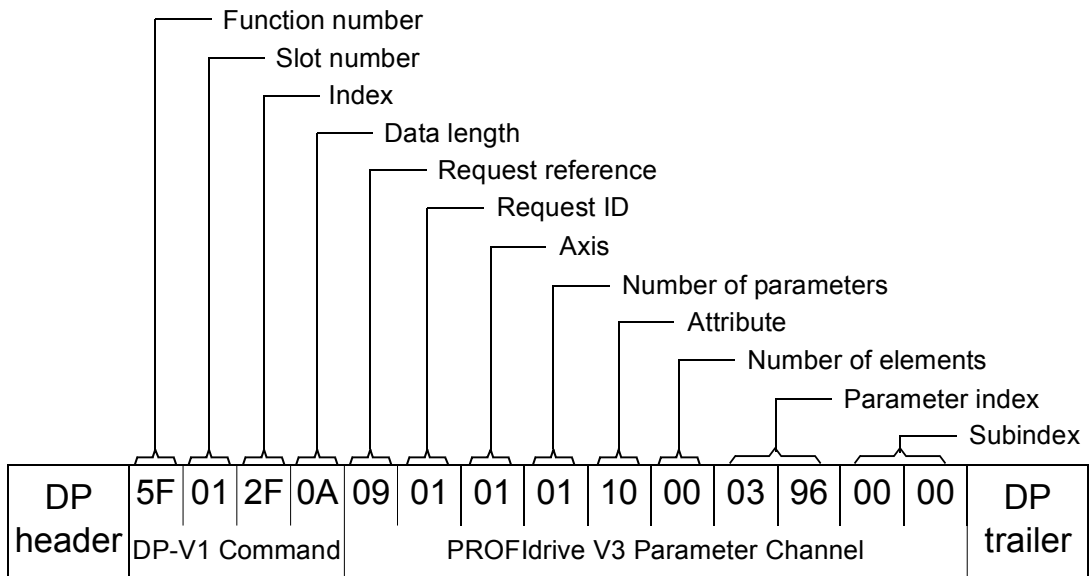

DP-V1 Read response

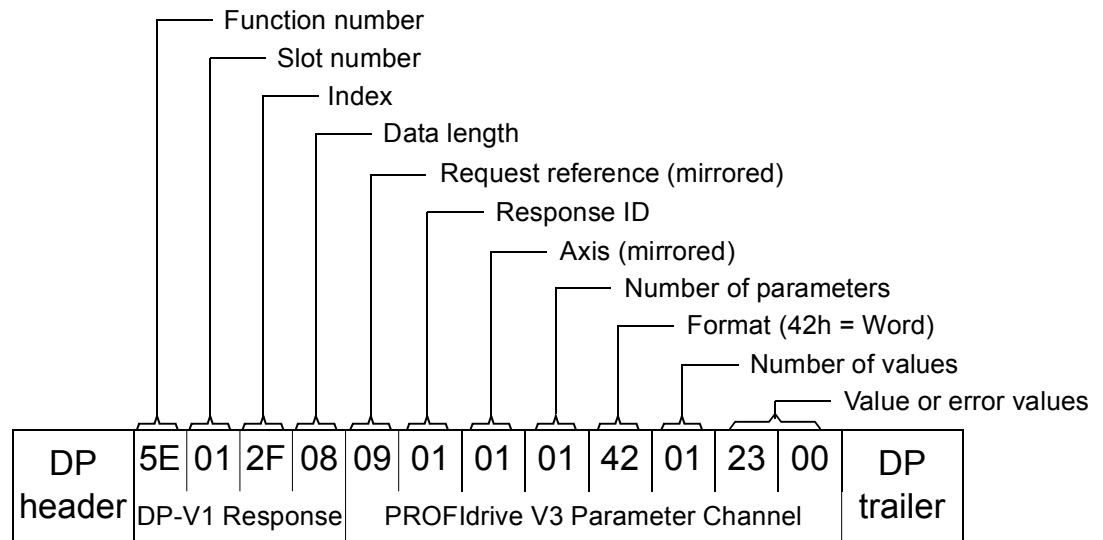

The slave returns the code of the latest acknowledged fault (2300h). The fault codes are according to the DRIVECOM standard. See also the User's Manual of the drive for drive specific fault codes.

The implementation of the PROFIdrive profile in the RPBA-01 supports the storage of the active and the five latest occurred different faults in the fault buffer. The fault codes can be accessed by PROFIdrive parameters 945, 947 and 948 (see Table 22 on page 101). The value zero indicates no fault. The subindexes of these parameters are related to each other, i.e. parameter 945 with subindex 1 relates to subindex of parameter 947 and 948.

Example 4: Configuring the process data written to the drive

PROFIBUS parameter No. 915 (393h) can be used to define which data is written cyclically to a drive parameter as application-specific process data.

In the example below, the value of drive parameter 12.06 (4B6h) is selected to be taken from PZD3. The parameter will continue to be updated with the contents of PZD3 in each Request frame until a different selection is made.

Subindex (IND) defines which process data word the required data is taken from. *Parameter Value* selects the drive parameter to which that word is mapped.

DP-V1 Write request

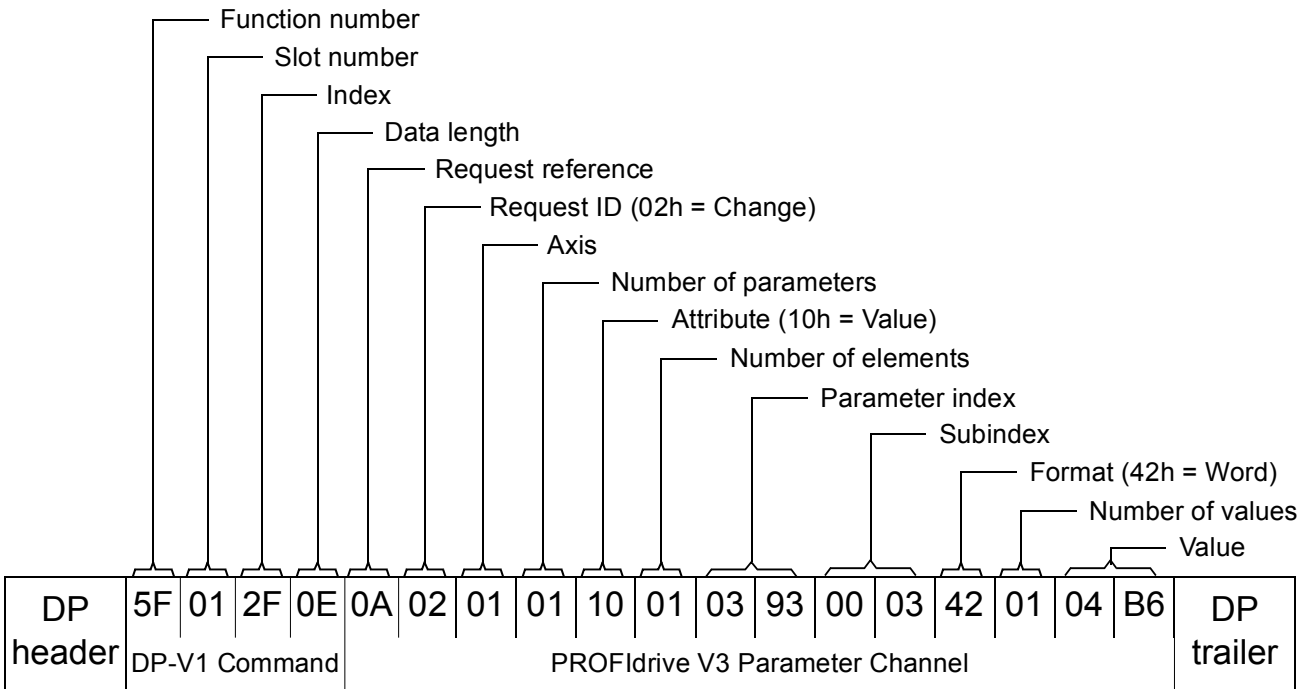

DP-V1 Read response

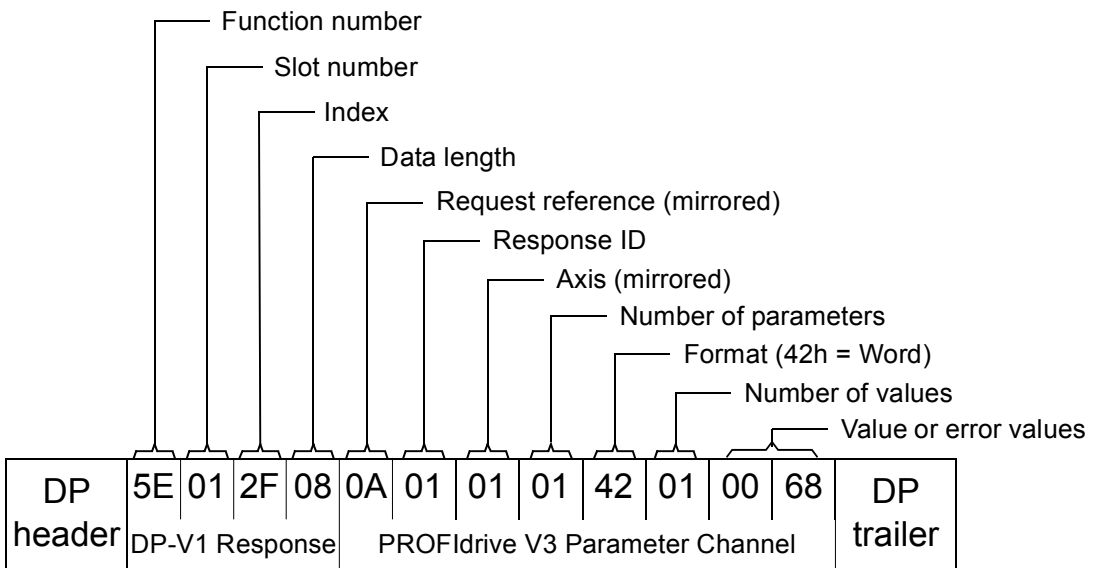

Subsequently, the contents of PZD3 in each Request frame are written to drive parameter 12.06 until a different selection is made.

Example 5: Determining the source of process data read from the drive

PROFIBUS Parameter No. 916 (394h) can be used to define which data is read cyclically from the drive as application-specific process data. In the example below, the parameter is used to determine which drive parameter the contents of PZD3 are taken from. *Subindex* (IND) defines which process data word the required data is transmitted in.

DP-V1 Write request

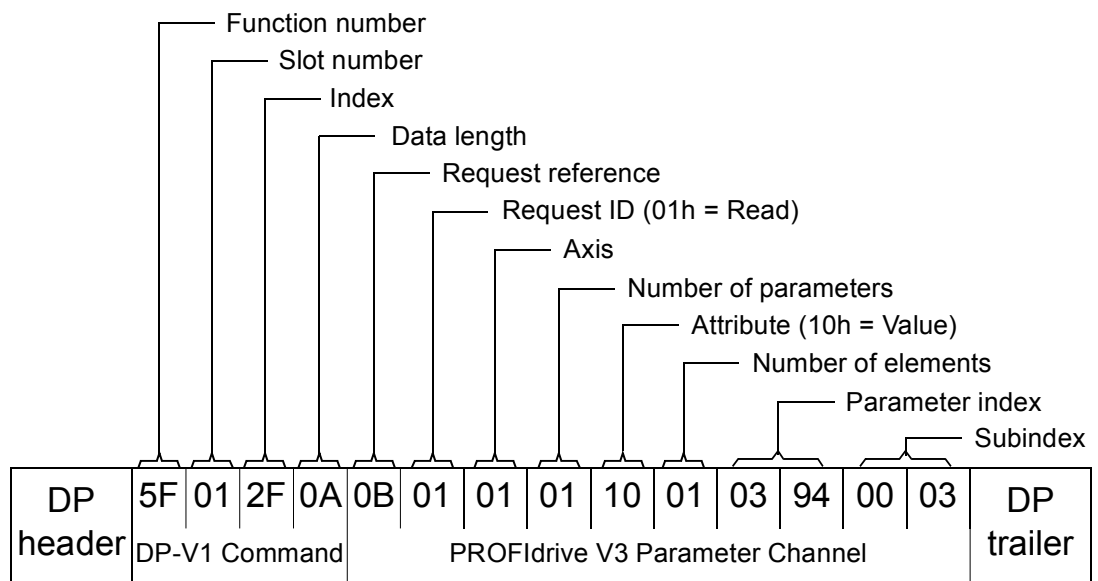

DP-V1 Read response

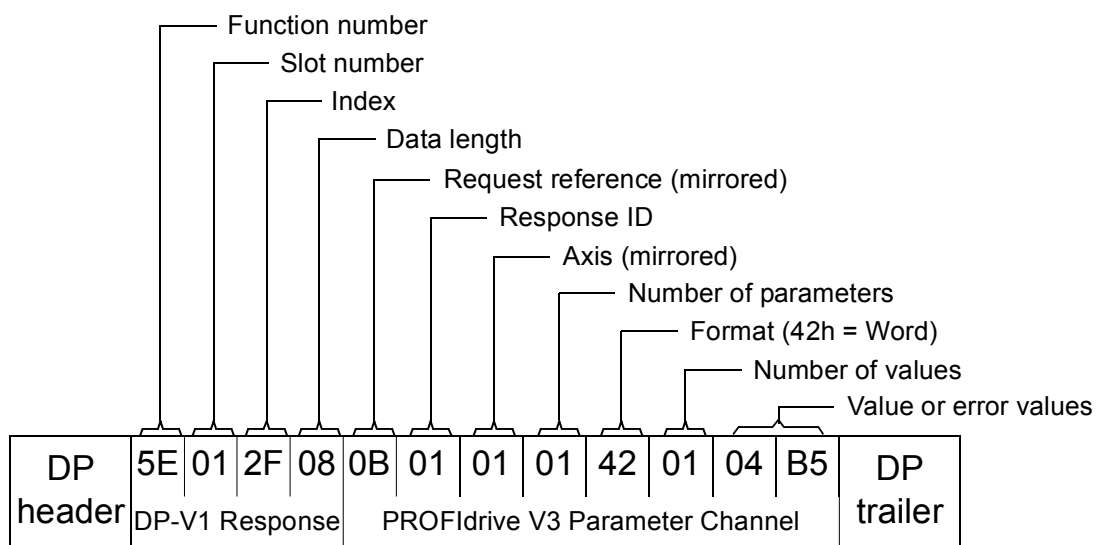

Value indicates the source of PZD3 as drive param. 12.05 (4B5h).

Fault tracing

LED indications

The RPBA-01 module is equipped with three diagnostic LEDs. The description of the LEDs is below.

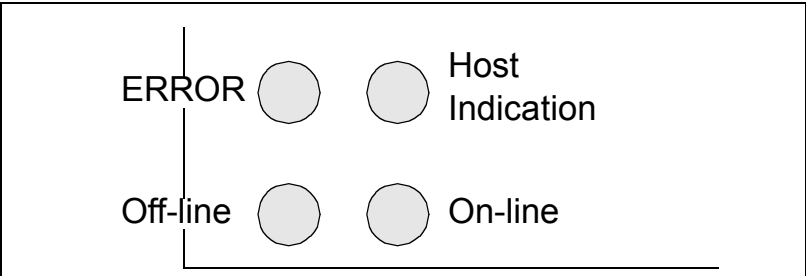

| Name | Colour | Function |
|----------|--------|--|
| ERROR | Red | <p>Flashing 1 Hz - Error in configuration: Internal configuration mismatch.</p> <p>Flashing 2 Hz - Error in User Parameter data: The length/contents of the User Parameter data set during initialisation of the module is not equal to the length/contents set during configuration of the network. Check that the selected DP mode matches the GSD file used (see configuration parameter 21 DP MODE on page 37).</p> <p>Flashing 4 Hz - Error in initialisation of the PROFIBUS communication ASIC.</p> <p>Off - No diagnostics present</p> |
| On-Line | Green | <p>Lit - Module is On-Line and data exchange is possible.</p> <p>Off - Module is not On-Line</p> |
| Off-Line | Red | <p>Lit - Module is Off-Line and no data exchange is possible.</p> <p>Off - Module is not Off-Line</p> |

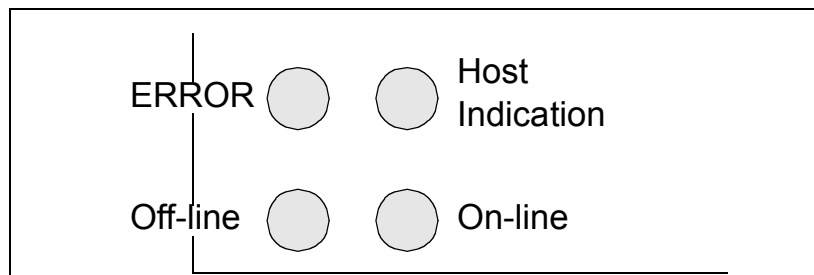

| Name | Colour | Function |
|-----------------|--------|---|
| Host Indication | Green | Lit - Link functional |
| | Red | Lit - Link lost permanently Flashing - Link lost temporarily |

PROFdrive parameters

Table 22. PROFdrive profile-specific parameters.

| Parameter | R/W* | Data type | Description | | | | | | | | | | | | | | | | | | |
|--------------|---|-----------------------|--|--------------|-----------------|----------------------|---|------|---|---|------|----------|---|------|-----|---|------|-----|---|------|----------|
| 915 | R/W | Array [10] Unsigned16 | Assignment PZD1 to PZD10 in PPO-write | | | | | | | | | | | | | | | | | | |
| 916 | R/W | Array [10] Unsigned16 | Assignment PZD1 to PZD10 in PPO-read | | | | | | | | | | | | | | | | | | |
| 918 | R/W | Unsigned16 | Node address. Writing this parameter will change the node address if the rotary switches have the setting 0. Module restart required. | | | | | | | | | | | | | | | | | | |
| 919 | R | Octet String4 | Device system number. | | | | | | | | | | | | | | | | | | |
| 927 | R/W | Unsigned16 | Operator control rights (parameter identification, PKW). <table border="0"> <tr> <td>Value</td> <td>Mode</td> </tr> <tr> <td>0</td> <td>Parameters cannot be written, only read (927 can be written)</td> </tr> <tr> <td>1</td> <td>Parameters can be written and read (default).</td> </tr> </table> | Value | Mode | 0 | Parameters cannot be written, only read (927 can be written) | 1 | Parameters can be written and read (default). | | | | | | | | | | | | |
| Value | Mode | | | | | | | | | | | | | | | | | | | | |
| 0 | Parameters cannot be written, only read (927 can be written) | | | | | | | | | | | | | | | | | | | | |
| 1 | Parameters can be written and read (default). | | | | | | | | | | | | | | | | | | | | |
| 928 | R/W | Unsigned16 | Control rights (process data, PZD). <table border="0"> <tr> <td>Value</td> <td>Mode</td> </tr> <tr> <td>0</td> <td>PZD part is disabled, i.e. Receipt of new PZD data is ignored</td> </tr> <tr> <td>1</td> <td>PZD part is enabled (default).</td> </tr> </table> | Value | Mode | 0 | PZD part is disabled, i.e. Receipt of new PZD data is ignored | 1 | PZD part is enabled (default). | | | | | | | | | | | | |
| Value | Mode | | | | | | | | | | | | | | | | | | | | |
| 0 | PZD part is disabled, i.e. Receipt of new PZD data is ignored | | | | | | | | | | | | | | | | | | | | |
| 1 | PZD part is enabled (default). | | | | | | | | | | | | | | | | | | | | |
| 929 | R | Unsigned16 | Selected PPO-type <table border="0"> <tr> <td>Value</td> <td>PPO-type</td> <td>Configuration</td> </tr> <tr> <td>1</td> <td>PPO1</td> <td>F3h, F1h</td> </tr> <tr> <td>2</td> <td>PPO2</td> <td>F3h, F5h</td> </tr> <tr> <td>3</td> <td>PPO3</td> <td>F1h</td> </tr> <tr> <td>4</td> <td>PPO4</td> <td>F5h</td> </tr> <tr> <td>5</td> <td>PPO5</td> <td>F3h, F9h</td> </tr> </table> | Value | PPO-type | Configuration | 1 | PPO1 | F3h, F1h | 2 | PPO2 | F3h, F5h | 3 | PPO3 | F1h | 4 | PPO4 | F5h | 5 | PPO5 | F3h, F9h |
| Value | PPO-type | Configuration | | | | | | | | | | | | | | | | | | | |
| 1 | PPO1 | F3h, F1h | | | | | | | | | | | | | | | | | | | |
| 2 | PPO2 | F3h, F5h | | | | | | | | | | | | | | | | | | | |
| 3 | PPO3 | F1h | | | | | | | | | | | | | | | | | | | |
| 4 | PPO4 | F5h | | | | | | | | | | | | | | | | | | | |
| 5 | PPO5 | F3h, F9h | | | | | | | | | | | | | | | | | | | |

| Parameter | R/W* | Data type | Description |
|-----------|------|------------|---|
| 930 | R/W | Unsigned16 | Selection switch for operation mode. Value Mode 1 Speed control mode: Control word and status word for frequency/speed used. 8001h Speed control mode: Control word and status word for torque used. |
| 933 | R/W | Unsigned16 | Selection switch for Control word, bit 11. Value Module Control word bit 0 None 1 to 5 Vendor specific 1 to 5* * The meaning of vendor specific bits is defined by drive application program. |
| 934 | R/W | Unsigned16 | Selection switch for Control word, bit 12. (See parameter 933 for coding) |
| 935 | R/W | Unsigned16 | Selection switch for Control word, bit 13. (See parameter 933 for coding) |
| 936 | R/W | Unsigned16 | Selection switch for Control word, bit 14. (See parameter 933 for coding) |
| 937 | R/W | Unsigned16 | Selection switch for Control word, bit 15. (See parameter 933 for coding) |
| 939 | R/W | Unsigned16 | Selection switch for Status word, bit 11. Value Module Status word bit 0 None 1 to 3 Vendor specific 1 to 3* * The meaning of vendor specific bits is defined by drive application program. |
| 940 | R/W | Unsigned16 | Selection switch for Status word, bit 12. (See parameter 939 for coding) |
| 941 | R/W | Unsigned16 | Selection switch for Status word, bit 13. (See parameter 939 for coding) |
| 942 | R/W | Unsigned16 | Selection switch for Status word, bit 14. (See parameter 939 for coding) |

| Parameter | R/W* | Data type | Description |
|-----------|------|-----------------------|--|
| 943 | R/W | Unsigned16 | Selection switch for Status word, bit 15. (See parameter 939 for coding) |
| 945 | R | Array[64] Unsigned16 | Fault code (coded according to DRIVECOM profile). Subindex Contents 1 Active fault 9 **Last ackn. fault 17 **Second last ackn. fault 25 **Third last ackn. fault 33 **Fourth last ackn. fault 41 **Fifth last ackn. fault |
| 947 | R | Array [64] Unsigned16 | Fault number. Subindex Contents See parameter 945. |
| 948 | R | Array [64] Unsigned16 | Time difference. Seconds since the last fault occurred. Subindex Contents See parameter 945. |
| 952 | R/W | Unsigned16 | Number of faults occurred. Writing a zero clears the value. |
| 953 | R | Unsigned16 | **Last alarm |
| 954 | R | Unsigned16 | **Second last alarm |
| 955 | R | Unsigned16 | **Third last alarm |
| 956 | R | Unsigned16 | **Fourth last alarm |
| 957 | R | Unsigned16 | **Fifth last alarm |
| 958 | R | Unsigned16 | Sixth last alarm (not supported) |
| 959 | R | Unsigned16 | Seventh last alarm (not supported) |
| 960 | R | Unsigned16 | Eighth last alarm (not supported) |
| 961 | R | Octet String4 | Hardware configuration (manufacturer specific ID of the drive) |

| Parameter | R/W* | Data type | Description | | | | | | |
|-----------|--|---------------|---|-------|-------------|---|-----------|---|--|
| 963 | R | Unsigned16 | Detected baud rate: 0 = 12 Mbit/s 1 = 6 Mbit/s 2 = 3 Mbit/s 3 = 1.5 Mbit/s 4 = 500 kbit/s 5 = 187.5 kbit/s 6 = 93.75 kbit/s 7 = 45.45 kbit/s 8 = 19.2 kbit/s 9 = 9.6 kbit/s 255 = Invalid baud rate | | | | | | |
| 964 | R | Unsigned16 | Identification number of this device (0812h) | | | | | | |
| 965 | R | Octet String2 | Profile number of this device (0302h) Profile 3, Version 2 | | | | | | |
| 967 | R | Unsigned16 | Control word (CW) | | | | | | |
| 968 | R | Unsigned16 | Status word (SW) | | | | | | |
| 970 | R/W | Unsigned16 | Load parameter record <table> <thead> <tr> <th>Value</th> <th>Description</th> </tr> </thead> <tbody> <tr> <td>0</td> <td>No action</td> </tr> <tr> <td>1</td> <td>Restore factory settings</td> </tr> </tbody> </table> The parameter must do a zero-to-one transition and the motor must be stopped. | Value | Description | 0 | No action | 1 | Restore factory settings |
| Value | Description | | | | | | | | |
| 0 | No action | | | | | | | | |
| 1 | Restore factory settings | | | | | | | | |
| 971 | R/W | Unsigned16 | Save parameter record <table> <thead> <tr> <th>Value</th> <th>Description</th> </tr> </thead> <tbody> <tr> <td>0</td> <td>No action</td> </tr> <tr> <td>1</td> <td>Save the drive parameters to non-volatile memory</td> </tr> </tbody> </table> The parameter must do a zero-to-one transition and the motor must be stopped. | Value | Description | 0 | No action | 1 | Save the drive parameters to non-volatile memory |
| Value | Description | | | | | | | | |
| 0 | No action | | | | | | | | |
| 1 | Save the drive parameters to non-volatile memory | | | | | | | | |

| Parameter | R/W* | Data type | Description | | | | | | |
|------------------|-------------------------|------------------|--|--------------|--------------------|---|-----------|---|-------------------------|
| 972 | R/W | Unsigned16 | Software reset <table border="0"> <thead> <tr> <th>Value</th> <th>Description</th> </tr> </thead> <tbody> <tr> <td>0</td> <td>No action</td> </tr> <tr> <td>1</td> <td>Re-boot PROFIBUS module</td> </tr> </tbody> </table> The parameter must do a zero-to-one transition and the motor must be stopped. | Value | Description | 0 | No action | 1 | Re-boot PROFIBUS module |
| Value | Description | | | | | | | | |
| 0 | No action | | | | | | | | |
| 1 | Re-boot PROFIBUS module | | | | | | | | |

* Read and/or Write

** Support depends on drive type

Definitions and abbreviations

PROFIBUS definitions

| | |
|------------------------------|---|
| <i>Acyclic Communication</i> | Communication in which messages are sent only once on request |
| <i>Array</i> | Parameter consisting of data fields of equal data type |
| <i>Broadcast</i> | Non-acknowledged message from master to all bus participants (compare Multicast) |
| <i>Command Word</i> | See Control Word |
| <i>Communication Object</i> | Any object of a real device that can be communicated with (variable, program, data range, etc.). Stored locally in the Object Dictionary. |
| <i>Control Word</i> | 16-bit word from master to slave with bit-coded control signals (sometimes called the Command Word). |
| <i>Cyclic Communication</i> | Communication in which Parameter-/Process Data-Objects are sent cyclically at pre-defined intervals |
| <i>Device Class</i> | Classification according to the number of profile functions included in the device |
| <i>Drivecast</i> | Broad- and Multicast, a special message frame for drives |
| <i>Fault</i> | Event that leads to tripping of the device |
| <i>GSD File</i> | ASCII-format device description file in a specified form. Each device (active & passive stations) on PROFIBUS has to have its own GSD File. |
| <i>Index</i> | Access reference for Objects in PROFIBUS |
| <i>Information Report</i> | Non-acknowledged message from master to one or all groups of bus participants |

| | |
|--------------------------------------|---|
| <i>Master</i> | Control system with bus initiative. In PROFIBUS terminology, master stations are also called active stations. |
| <i>Multicast</i> | Non-acknowledged message from master to one group of bus participants (compare Broadcast) |
| <i>Name</i> | Symbolic name of a parameter |
| <i>Nibble</i> | Set of 4 bits |
| <i>Object Dictionary</i> | Local storage of all Communication Objects recognised by a device |
| <i>Object List</i> | List of all accessible objects |
| <i>Parameter</i> | Value that can be accessed as Object, e.g. variable, constant, signal |
| <i>Parameter Number</i> | Parameter address |
| <i>Parameter/Process Data Object</i> | Special object that contains Parameter and Process Data |
| <i>Process Data</i> | Data that contains Control Word and Reference value or Status Word and Actual value. May also contain other (user-definable) control information. |
| <i>Profile</i> | Adaptation of the protocol for certain application field, e.g. drives |
| <i>Request Label</i> | Coded information specifying the required service for the parameter part sent from master to slave |
| <i>Response Label</i> | Coded information specifying the required service for the parameter part sent from slave to master |
| <i>Slave</i> | Passive bus participant. In PROFIBUS terminology, slave stations (or slaves) are also called passive stations. Also referred to as node. |
| <i>Status Word</i> | 16-bit word from slave to master with bit-coded status messages |

Warning Signal caused by an existing alarm which does not lead to tripping of the device

PROFIBUS abbreviations

The text in *italics* is the original German term.

| | |
|---------------|---|
| <i>.con</i> | Confirmation |
| <i>.ind</i> | Indication |
| <i>.req</i> | Request |
| <i>.res</i> | Response |
| <i>ACT</i> | Actual Value <i>Istwert</i> |
| <i>AK</i> | Request Label/Response Label <i>Auftragskennung/Antwortkennung</i> |
| <i>ALI</i> | Application Layer Interface |
| <i>CR</i> | Communication Reference <i>Kommunikationsreferenz (Kommunikationsbeziehung)</i> |
| <i>DP</i> | Decentralised Periphery <i>Dezentrale Peripherie</i> |
| <i>DP-ALI</i> | Application Layer Interface for DP |
| <i>DP-V1</i> | PROFIBUS DP Extensions to the EN 50170 standard, including e.g. acyclic data exchange |
| <i>FDL</i> | Fieldbus Data Link |
| <i>FMS</i> | Fieldbus Message Specification |
| <i>FSU</i> | Manufacturer Specific Interface <i>Firmenspezifischer Umsetzer</i> |
| <i>HIW</i> | Main Actual Value <i>Hauptistwert</i> |
| <i>HSW</i> | Main Reference <i>Hauptsollwert</i> |

| | |
|----------------|--|
| <i>ISW</i> | see ACT |
| <i>KR (KB)</i> | see CR |
| <i>PA</i> | Process Automation <i>Prozessautomatisierung</i> |
| <i>PD</i> | Process Data <i>Prozessdaten</i> |
| <i>PKE</i> | Parameter Identification <i>Parameter-Kennung</i> |
| <i>PKW</i> | Parameter Identification Value <i>Parameter-Kennung-Wert</i> |
| <i>PNU</i> | Parameter Number <i>Parameternummer</i> |
| <i>PPO</i> | Parameter/Process Data Object <i>Parameter-/Prozessdaten-Objekt</i> |
| <i>PWE</i> | Parameter Value <i>Parameter-Wert</i> |
| <i>PZD</i> | see PD |
| <i>PZDO</i> | Process Data Object <i>Prozessdatenobjekt</i> |
| <i>SAP</i> | Service Access Point |
| <i>SOW</i> | Reference <i>Sollwert</i> |
| <i>SPM</i> | Request Signal <i>Spontanmeldung</i> |
| <i>STW</i> | Control Word <i>Steuerwort</i> |
| <i>ZSW</i> | Status Word <i>Zustandswort</i> |

Technical data

RPBA-01

Enclosure:

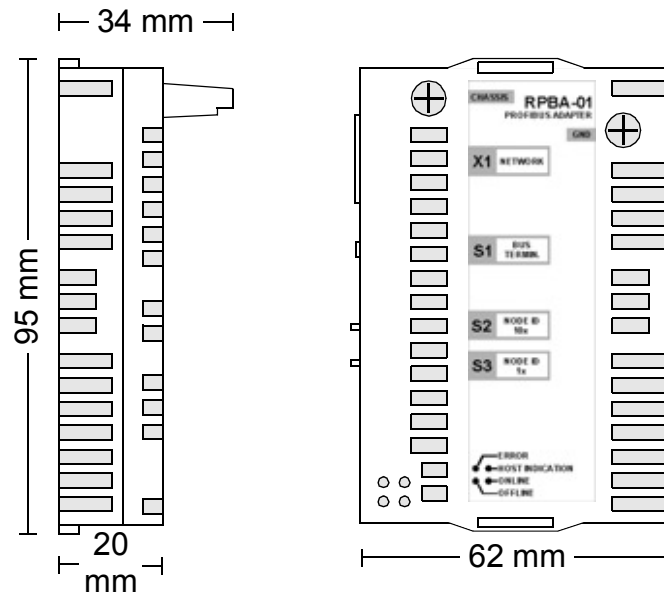

Mounting: Into the option slot on the control board of the drive.

Degree of protection: IP20

Ambient conditions: The applicable ambient conditions specified for the drive in its *Hardware Manual* are in effect.

Hardware settings:

- Rotary switches for node address selection (address range 00 to 99)
- DIP switch for bus termination selection

Software settings:

- Input/Output/User Parameter data/Diagnostics format
- Maximum cyclic I/O data size: 28 bytes in, max 28 bytes out, max. 56 bytes total
- Maximum acyclic I/O data size: 240 bytes in, max. 240 bytes out, max. 480 bytes total
- Maximum User Parameter data/Diagnostics length: 26 bytes

Connectors:

- 34-pin parallel bus connector
- 9-pin female DSUB connector

Current consumption:

- 350 mA max. (5 V), supplied by the control board of the drive

General:

- Estimated min. lifetime: 100 000 h
- All materials UL/CSA-approved
- Complies with EMC standards EN 50081-2 and EN 50082-2

PROFIBUS link

Compatible devices: All devices compatible with the PROFIBUS DP protocol

Size of the link: 127 stations including repeaters (31 stations and 1 repeater per segment)

Medium: Shielded, twisted pair RS-485 cable

- Termination: built in the module
- Specifications:

| Parameter | Line A PROFIBUS DP | Line B DIN 19245 Part 1 | Unit |
|----------------|-----------------------------|-----------------------------|-----------------|
| Impedance | 135 to 165 (3 to 20 MHz) | 100 to 130 (f > 100 kHz) | W |
| Capacitance | < 30 | < 60 | pF/m |
| Resistance | < 110 | – | Ω /km |
| Wire gauge | > 0.64 | > 0.53 | mm |
| Conductor area | > 0.34 | > 0.22 | mm ² |

- Maximum bus length:

| | | | | | | | |
|-------------------------------|--------------|-------|-----|------|------|------|-------|
| Transfer rate (kbit/s) | ≤ 93.75 | 187.5 | 500 | 1500 | 3000 | 6000 | 12000 |
| Line A (m) | 1200 | 1000 | 400 | 200 | 100 | 100 | 100 |
| Line B (m) | 1200 | 600 | 200 | – | – | – | – |

Topology: Multi-drop

Serial communication type: Asynchronous, half Duplex

Transfer rate: 9.6 kbit/s, 19.2 kbit/s, 45.45 kbit/s, 93.75 kbit/s, 187.5 kbit/s, 500 kbit/s, 1.5 Mbit/s, 3 Mbit/s, 6 Mbit/s, or 12 Mbit/s (automatically detected by RPBA-01)

Protocol: PROFIBUS DP



ABB Oy

AC Drives

P.O. Box 184

FIN-00381 HELSINKI

FINLAND

Telephone +358 10 22 11

Fax +358 10 22 22681

Internet <http://www.abb.com>

ABB Inc.

Automation Technologies

Drives & Motors

16250 West Glendale Drive

New Berlin, WI 53151

USA

Telephone 262 785-3200

800-HELP-365

Fax 262 780-5135

3AFE64504215 REV F EN
EFFECTIVE: 20.06.2005