

Micro Motion[®] Heavy Fuel Viscosity Meter (HFVM) Viscomaster[™]

High-performance multi-variable viscosity meter



World-wide marine-approved design for aggressive environments

- Continuous, multi-variable measurement of viscosity, density, and temperature
- Accurate measurement of viscosity ($\pm 1\%$ of full scale) and density ($\pm 1 \text{ kg/m}^3$)
- Optimized design that is insensitive to vibration, temperature, and pressure variations
- Durable Diamond-Like Carbon (DLC) coating that is resistant to friction, chemicals, impact, and mechanical damage

Superior multi-variable I/O and meter health

- Hazardous-area approved, head-mounted transmitter that supports local configuration and display
- Internal diagnostics for fast verification of meter health and installation

Installation flexibility and compatibility

- Direct-insertion design for inline measurement
- 4-20 mA, HART, and Modbus protocol connection to control systems and external devices
- Retrofit kits for replacing capillary and torsional meters
- Upgrades for 7829 Viscomaster systems

Micro Motion® HFVM meters

The HFVM measures liquid viscosity, density, and temperature in aggressive environments. These meters use vibrating fork technology for reliable direct-insertion measurement. HFVMs provide Heavy Fuel Oil (HFO)/Marine Gas Oil (MGO) combustion control, and oil-fired heater and boiler control.

Marine and power applications

Rugged, reliable, and low maintenance, these meters are the industry standard for HFO measurement applications.

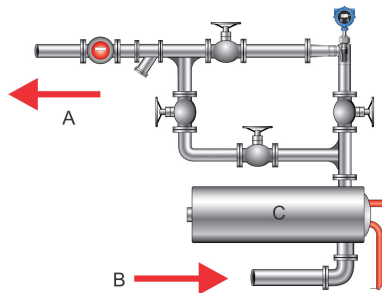

- A. To engine
- B. Fuel oil
- C. Fuel oil heat exchange

Application configurations

Integral HART I/O direct input of external temperature, pressure, and flow measurements provide enhanced readings.

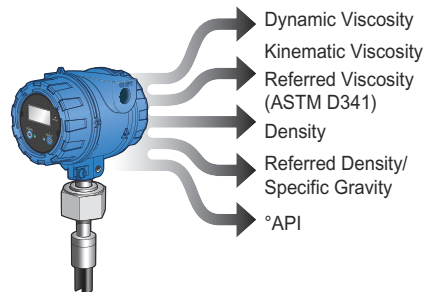

Integral transmitter

Supports Analog (4-20 mA), HART, WirelessHART®, and Modbus RS-485 communications.

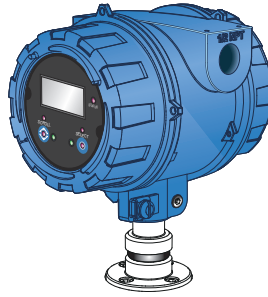

Meter diagnostics

Ensure measurement health through known density verification (KDV) and other meter and installation diagnostic capabilities.

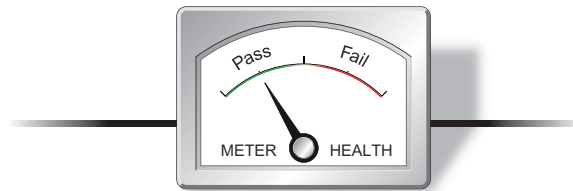

Retrofit capabilities

The HFVM has installation options for replacing capillary and torsional meters that give you the performance you need.

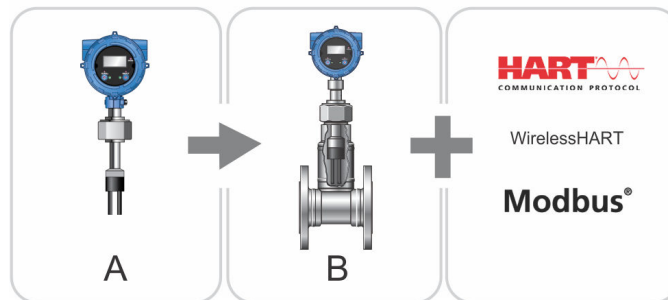

- A. Power, RS-485 2 x mA outputs
- B. Adapters

ProLink® III software: a configuration and service tool

ProLink III software is an easy-to-use interface that allows you to view key process variables and diagnostics data for your meter. For more information on ordering the software, contact your local sales representative or email customer support at flow.support@emerson.com.

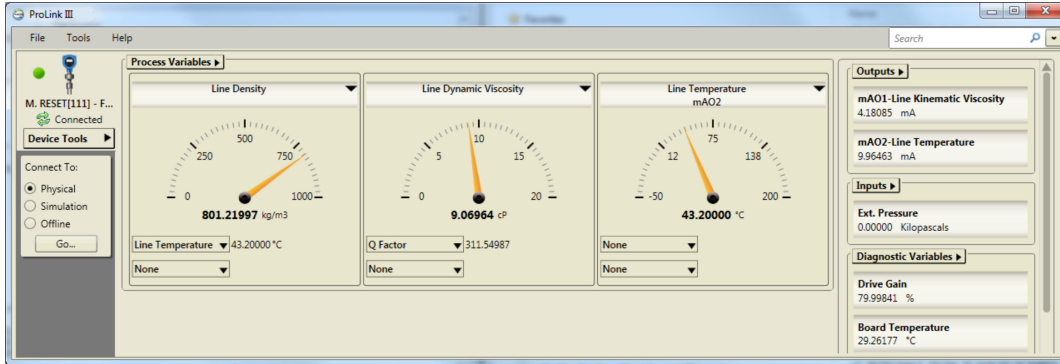

Operating principle

Fork vibration

- A fully welded fork assembly is inserted directly into the liquid to be measured.
- Using piezoelectricity, the fork tines vibrate at natural frequency.

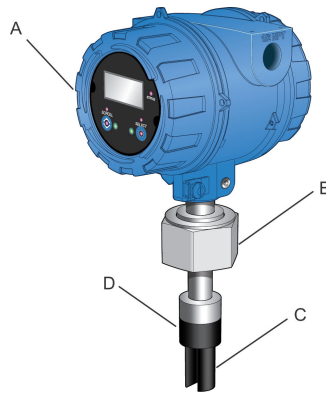

- A. Integral transmitter with optional local operator interface
- B. Cone seat compression fitting
- C. Vibrating tines
- D. RTD measures temperature

Temperature measurement

- An integral class “B” RTD measures the vibrating fork temperature.
- Micro Motion transmitters use this reading to optimize performance over a wide range of process conditions.

Density calibration

- The tines' natural frequency changes with the density of the surrounding liquid.
- Micro Motion transmitters accurately measure time period.
- Measured time periods are converted into density readings using meter calibration coefficients.

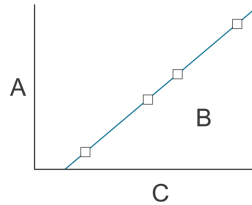

- A. Density (kg/m³)
- B. Time period = 1 / frequency
- C. [Time period]² (μs²)

Viscosity calibration

- The bandwidth of the tines' natural frequency changes with the viscosity of the surrounding liquid.
- Micro Motion transmitters accurately measure bandwidth.
- Bandwidth measurements are converted into viscosity readings using meter calibration coefficients.

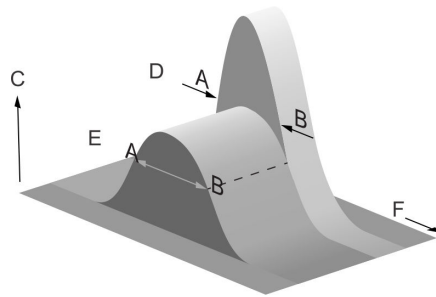

- A. Point A
- B. Point B
- C. Response amplitude
- D. Product 1 = low viscosity
- E. Product 2 = high viscosity
- F. Frequency (Hz)

Note

- Bandwidth = point B - point A
 - Resonant frequency = (point A + point B) / 2
 - Quality factor = resonant frequency / bandwidth
-

Performance specifications

Viscosity measurement

Specification	Value	
Calibration range and accuracy	Calibration code	Accuracy
	0.5 to 10 cP	±0.2 cP
	10 to 100 cP	±1% of calibration range maximum
Standard calibration range options	0.5 to 100 cP	
Repeatability	±0.5% of reading	

Density measurement (calibration code B only)

Specification	Value	
Accuracy	±1 kg/m ³	±0.001 g/cm ³
Operating density range	0 to 3000 kg/m ³	0 to 3.0 g/cm ³
Calibration range	600 to 1250 kg/m ³	0.6 to 1.25 g/cm ³
Repeatability	±0.1 kg/m ³	±0.0001 g/cm ³
Process temperature effect (corrected)	±0.1 kg/m ³ per °C	±0.0001 g/cm ³ per °C
Process pressure effect (corrected)	None	

Temperature measurement

Specification	Value	
Operating temperature range	-50 °C to +200 °C	-58 °F to +392 °F
Integral temperature measurement	<ul style="list-style-type: none"> ■ Technology: 100 Ω RTD ■ Accuracy: BS1904 Class, DIN 43760 Class B 	

Pressure ratings

Actual maximum operating pressures are limited by the process connection rating.

Specification	Value	
Maximum operating pressure	100 bar	1450 psi (cone-seated fitting)
Test pressure	Tested to 1.5 times the maximum operating pressure	
PED compliance	Not applicable	

Transmitter specifications

Transmitter features and process variables

	Feature		Process variables	
	Calibration code B	Calibration code R	Calibration code B	Calibration code R
Process measurement				
Viscosity measurement	Yes	Yes	Dynamic viscosity Kinematic viscosity	Dynamic viscosity Kinematic viscosity
Density measurement	Direct	Derived ⁽¹⁾	Density	Density ⁽²⁾
Two-phase flow detection	Yes	No	N/A	N/A
Internal temperature	Yes	Yes	Temperature	Temperature
Ignition quality	Yes	No	CCAI CII	N/A
Measurement applications				
Referred viscosity ⁽³⁾	Yes	No	Referred viscosity (dynamic or kinematic)	N/A
API referral	Yes	No	Referred density (API)	N/A
Measurement diagnostics				
Known Density Verification (KDV)	Yes	No	N/A	N/A

(1) Calculated from reference density and reference temperature using the API equations for crude oil.

(2) Derived value

(3) Three methods: ASTM D341 single-curve, ASTM D341 multi-curve, and matrix referral.

Transmitter I/O and communications

Typical application	Transmitter version	Output channels		
		A	B	C
Marine and power HFO combustion control, and oil-fired heater and boiler control	Analog	4-20 mA + HART	4-20 mA	RS-485/Modbus

Local display

Design	Features
Physical	<ul style="list-style-type: none"> ■ Segmented two-line LCD screen. ■ Can be rotated on transmitter, in 90-degree increments, for ease of viewing. ■ Suitable for hazardous area operation. ■ Optical switch controls for hazardous area configuration and display. ■ Glass lens. ■ Three-color LED indicates meter and alert status.
Functions	<ul style="list-style-type: none"> ■ View process variables. ■ View and acknowledge alerts. ■ Configure mA and RS-485 outputs. ■ Supports Known Density Verification (KDV). ■ Supports multiple languages.

Additional communication options



The following communications accessories are purchased separately from the meter.

Type	Description
WirelessHART®	WirelessHART is available via the THUM adapter
HART® Tri-Loop	Three additional 4-20 mA outputs are available via connection to a HART Tri-Loop

Hazardous area approvals

Ambient and process temperature limits are defined by temperature graphs for each meter and electronics interface option. Refer to the detailed approval specifications, including temperature graphs for all meter configurations, and safety instructions. See the product page at www.emerson.com.

ATEX, CSA, and IECEx approvals

ATEX		
Zone 1 Flameproof	Without display 	■ II 1/2G Ex d IIC T6 Ga/Gb
Zone 2	Without display 	■ II 3G Ex nA IIC T6 Gc
	With display 	■ II 3G Ex nA IIC T4 Gc

CSA	
Explosion proof	Without display <ul style="list-style-type: none"> ■ Class I, Division 1, Groups C & D ■ Class I, Division 2, Groups A, B, C & D ■ Class II, Division 1, Groups E, F & G
	With display <ul style="list-style-type: none"> ■ Class I, Division 2, Groups A, B, C & D

IECEX	
Zone 1 Flameproof	Without display <ul style="list-style-type: none"> ■ Ex d IIC T6 Ga/Gb
Zone 2	Without display <ul style="list-style-type: none"> ■ Ex nA IIC T6 Gc
	With display <ul style="list-style-type: none"> ■ Ex nA IIC T4 Gc

Marine approval classifications

Marine approval	Country
Lloyd's Register	United Kingdom
Germanische Lloyd	Germany
Det Norske Veritas	Norway
Bureau Veritas	France
American Bureau of Shipping	USA

Environmental specifications

Type	Rating	
Electromagnetic compatibility	All versions conform to the latest international standards for EMC, and are certified compliant with EN 61326	
Ambient temperature	-40 °C to +65 °C	-40 °F to +149 °F
Ingress protection rating	IP66/67, CSA Type 4	

Power requirements

Type	Description
DC Power requirements	<ul style="list-style-type: none"> ▪ 24 VDC, 0.65 W typical, 1.1 W maximum ▪ Minimum recommended voltage: 21.6 VDC with 1000 ft of 24 AWG (300 m of 0.20 mm²) power-supply cable ▪ At startup, power source must provide a minimum of 0.5 A of short-term current with a minimum of 19.6 V at the power input terminals.

Physical specifications

Construction materials

Component	Material
Wetted parts	316L stainless steel
Tine finish	DLC (Diamond-Like Carbon) coated
Transmitter housing	Polyurethane-painted aluminum

Weight

Specification	Value	
Weight (typical)	6.7 kg	15 lbs

Dimensions

Use these dimensional drawings as a basic guideline for sizing and planning. For complete and detailed dimensional drawings, see the product drawings link at the Micro Motion online store at www.emerson.com.

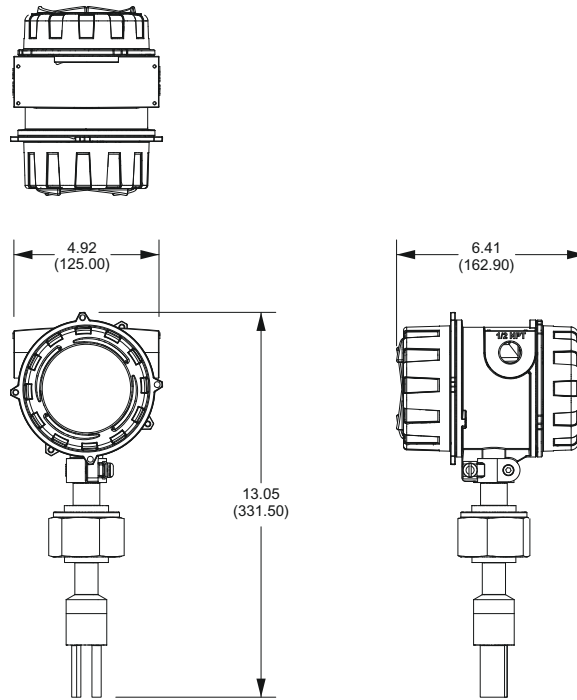

Note

Dimensions are in inches (mm)

Installation and retrofit accessories

A variety of installation accessories are available for both inline and slipstream/bypass installations. Additionally, you can replace other viscosity measurement technologies using retrofit adapter kits. For more information on these installation accessories, see the Micro Motion Insertion Density and Viscosity Meter Accessories product data sheet available at www.emerson.com.

Fuel heater control example

Most marine and land-based engine/burner applications use a fuel booster module to precondition the heavy fuel oil (HFO) prior to injection. These modules usually consist of a number of supply pumps fed by either HFO or MDO, a flow meter, inline filters to remove the impurities, and a holding/mixing tank.

Following the supply section, the fuel is usually sent to booster pumps that increase the flow rate up to a maximum of 20 m³/hr, and then through a series of liquid or electric heat exchangers to change the product viscosity for efficient combustion.

The following graphic shows different installation options for the HFVM in a fuel booster module.

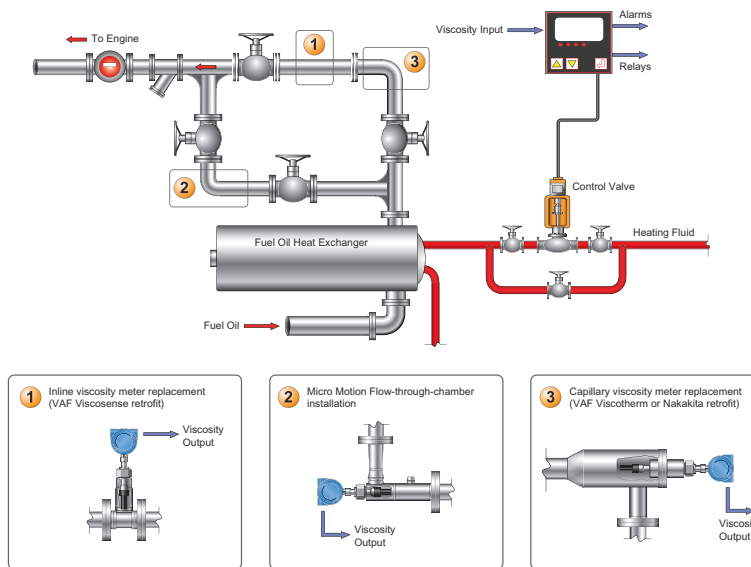

Ordering information

Model	Description
HFVM	Heavy Fuel Viscosity Meter (HFVM) Viscomaster

Code	Sensor calibration code and performance
1	Viscosity accuracy $\pm 0.2\text{cSt}$ (0-10cSt range) then $\pm 1\%$ FS, viscosity limit 100cSt

Code	Stem length
1	0 mm: no stem extension and with standard spigot

Code	Materials of wetted parts (including process connection)
L	316L stainless steel, Diamond-Like Carbon (DLC) coated tines
X	Special order (ETO) material of wetted parts

Code	Process connections
729	1-1/2 inch, cone-seat compression fitting, 316/316L
999	Special order (ETO) process connection

Code	Sensor calibration types
B	2-inch schedule 40 boundary
E	3-inch schedule 80 boundary
H	2-1/2 inch schedule 40 boundary
J	DN80 boundary – Viscosity limits = 1000cSt (782791 Flow Through Chamber)

Code	Sensor calibration types
X	Special order (ETO) calibration type: Requires X factory option

Code	Transmitter housing option
A	Integral, aluminum alloy

Code	Transmitter outputs option
C	Integral transmitter, Channel A = mA + HART, Channel B = mA output, Channel C = RS485 Modbus

Code	Display option
Available with approvals codes M, 2, V and 3 only	
2	Integral two-line display (non-backlit)
Available with all approvals codes	
3	No display

Code	Approvals
M	Safe area - no hazardous area approval
2	CSA Class 1, Div 2 (US and Canada)
V	ATEX equipment category 3 (zone 2)
3	IECEX zone 2
A	CSA (US and Canada) explosion-proof
F	ATEX - zone 1 flameproof
I	IECEX - zone 1 flameproof
G	Country-specific approval. Requires an R1 or R2 selection from the <i>Special tests and certificates, tests, calibrations and services (optional)</i> table.

Code	Primary mA output (Channel A): Default process variable and scaling
H	Line viscosity (4 mA = 0 cSt, 20 mA = 25 cSt)
J	Line viscosity (4 mA = 0 cSt, 20 mA = 50 cSt)
E	Line viscosity (4 mA = 0 cSt, 20 mA = 100 cSt)
X	Special order (ETO) mA output configuration (customer data required): Requires X factory option

Code	Calibration code
B	0.5 to 100 cP viscosity and density calibration
R	5 to 50 cP viscosity calibration only
X	Special order (ETO) calibration code: Requires X factory option

Code	Language (manual and software)
Transmitter display language English	

Code	Language (manual and software)
E	English installation manual and English configuration manual
I	Italian installation manual and English configuration manual
M	Chinese installation manual and English configuration manual
R	Russian installation manual and English configuration manual
Transmitter display language French	
F	French installation manual and English configuration manual
Transmitter display language German	
G	German installation manual and English configuration manual
Transmitter display language Spanish	
S	Spanish installation manual and English configuration manual

Code	Future option 1
Z	Reserved for future use

Code	Conduit connections
Z	Standard 1/2-inch NPT fittings (no adapters)
B	M20 stainless steel adapters

Code	Factory options
Z	Standard product
X	Special order (ETO) product

Code	Special tests and certificates, tests, calibrations and services (optional)
Material quality examination tests and certificates	
MC	Material Inspection Certificate 3.1 (Supplier Lot Traceability per EN 10204)
NC	NACE Certificate 2.1 (MR0175 and MR0103)
Pressure testing	
HT	Hydrostatic Test Certificate 3.1 (Pressure-retaining parts only)
Dye penetrant examination	
D1	Dye Penetrant Test Package 3.1 (Sensor only; Liquid Dye Penetration NDE Qualification)
Weld examination	
WP	Weld Procedure Package (Weld Map, Weld Procedure Specification, Weld Procedure Qualification Record, Welder Performance Qualification)
Positive material testing (select only one from this group)	
PM	Positive Material Test Certificate 3.1 (without carbon content)
PC	Positive Material Test Certificate 3.1 (including carbon content)
Sensor completion options	
WG	Witness General

Code	Special tests and certificates, tests, calibrations and services (optional)
SP	Special Packaging
Instrument tagging	
TG	Instrument Tagging - customer information required (max. 24 characters)
Country-specific approvals (Select only one when Approvals option G is selected)	
R1 ⁽¹⁾ (2)	EAC Zone 1 - Hazardous area approval - intrinsically safe
R2 ⁽¹⁾ (2)	EAC Zone 1 - Hazardous area approval - flameproof terminal compartment

(1) Available only with approval G

(2) Not available with Transmitter Output Options code F or Transmitter Housing Option B

**Emerson Automation Solutions
Micro Motion Americas**

Worldwide Headquarters
7070 Winchester Circle
Boulder, Colorado USA 80301
T: +1 800-522-6277
T: +1 303-527-5200
F: +1 303-530-8459
Mexico: 52 55 5809 5300
Argentina: 54 11 4837 7000
Brazil: 55 15 3413 8147
Chile: 56 2 2928 4800

**Emerson Automation Solutions
Micro Motion Europe/Middle East**

Central Europe: +41 41 7686 111
Eastern Europe: +41 41 7686 111
Dubai: +971 4 811 8100
Abu Dhabi: +971 2 697 2000
France: 0800 917 901
Germany: +49 (0) 2173 3348 0
Italy: 8008 77334
The Netherlands: +31 (0) 70 413 6666
Belgium: +32 2 716 77 11
Spain: +34 913 586 000
U.K.: 0870 240 1978
Russian/CIS: +7 495 981 9811

**Emerson Automation Solutions
Micro Motion Asia Pacific**

Australia: (61) 3 9721 0200
China: (86) 21 2892 9000
India: (91) 22 6662 0566
Japan: (81) 3 5769 6803
South Korea: (82) 31 8034 0000
Singapore: (65) 6 777 8211

©2017 Micro Motion, Inc. All rights reserved.

The Emerson logo is a trademark and service mark of Emerson Electric Co. Micro Motion, ELITE, ProLink, MVD and MVD Direct Connect marks are marks of one of the Emerson Automation Solutions family of companies. All other marks are property of their respective owners.