

Instruction Manual

CI-ControlWave EPAC

Part: D301384X012

March, 2011

ControlWave ExpressPAC

**ControlWave ExpressPAC
(Process Automation Controller / Remote Terminal Unit)**



IMPORTANT! READ INSTRUCTIONS BEFORE STARTING!

Be sure that these instructions are carefully read and understood before any operation is attempted. Improper use of this device in some applications may result in damage or injury. The user is urged to keep this book filed in a convenient location for future reference.

These instructions may not cover all details or variations in equipment or cover every possible situation to be met in connection with installation, operation or maintenance. Should problems arise that are not covered sufficiently in the text, the purchaser is advised to contact Emerson Process Management, Remote Automation Solutions division (RAS) for further information.

EQUIPMENT APPLICATION WARNING

The customer should note that a failure of this instrument or system, for whatever reason, may leave an operating process without protection. Depending upon the application, this could result in possible damage to property or injury to persons. It is suggested that the purchaser review the need for additional backup equipment or provide alternate means of protection such as alarm devices, output limiting, fail-safe valves, relief valves, emergency shutoffs, emergency switches, etc. If additional information is required, the purchaser is advised to contact RAS.

RETURNED EQUIPMENT WARNING

When returning any equipment to RAS for repairs or evaluation, please note the following: The party sending such materials is responsible to ensure that the materials returned to RAS are clean to safe levels, as such levels are defined and/or determined by applicable federal, state and/or local law regulations or codes. Such party agrees to indemnify RAS and save RAS harmless from any liability or damage which RAS may incur or suffer due to such party's failure to so act.

ELECTRICAL GROUNDING

Metal enclosures and exposed metal parts of electrical instruments must be grounded in accordance with OSHA rules and regulations pertaining to "Design Safety Standards for Electrical Systems," 29 CFR, Part 1910, Subpart S, dated: April 16, 1981 (OSHA rulings are in agreement with the National Electrical Code).

The grounding requirement is also applicable to mechanical or pneumatic instruments that include electrically operated devices such as lights, switches, relays, alarms, or chart drives.

EQUIPMENT DAMAGE FROM ELECTROSTATIC DISCHARGE VOLTAGE

This product contains sensitive electronic components that can be damaged by exposure to an electrostatic discharge (ESD) voltage. Depending on the magnitude and duration of the ESD, this can result in erratic operation or complete failure of the equipment. Read supplemental document S14006 for proper care and handling of ESD-sensitive components.

Remote Automation Solutions

A Division of Emerson Process Management
1100 Buckingham Street, Watertown, CT 06795
Telephone (860) 945-2200

Emerson Process Management *Training*

GET THE MOST FROM YOUR EMERSON INSTRUMENT OR SYSTEM

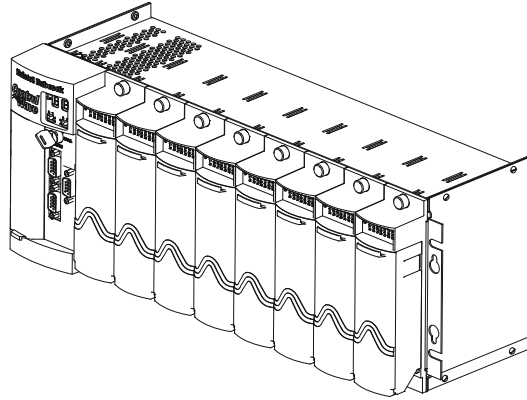

- Avoid Delays and problems in getting your system on-line
- Minimize installation, start-up and maintenance costs.
- Make the most effective use of our hardware and software.
- Know your system.

As you know, a well-trained staff is essential to your operation. Emerson offers a full schedule of classes conducted by full-time, professional instructors. Classes are offered throughout the year at various locations. By participating in our training, your personnel can learn how to install, calibrate, configure, program and maintain your Emerson products and realize the full potential of your system.

For information or to enroll in any class, go to <http://www.EmersonProcess.com/Remote> and click on “Educational Services” or contact our training department in Watertown at (860) 945-2200.

This page is intentionally left blank

Contents

Chapter 1 – Introduction 1-1

1.1	Scope of the Manual	1-2
1.2	Physical Description	1-2
1.3	CPU/System Controller Board	1-4
1.4	Power Options	1-6
1.5	I/O Options	1-6
1.6	Software Tools	1-7

Chapter 2 – Installation 2-1

2.1	Site Considerations	2-1
2.1.1	Class I, Div 2 Installation Considerations.....	2-3
2.2	Installation Overview	2-3
2.2.1	Mounting the Housing	2-4
2.2.2	Grounding the Housing	2-9
2.3	Configuring the CPU/System Controller Board.....	2-10
2.3.1	Setting DIP Switches on the CPU/System Controller Board	2-11
2.3.2	Setting Jumpers on the CPU/System Controller Board	2-13
2.3.3	General Wiring Guidelines	2-14
2.3.4	Wiring Power to the CPU/System Controller Board.....	2-14
2.3.5	Mounting the Solar Panel.....	2-18
2.3.6	Connections to RS-232 Serial Port(s) on the CPU/System Controller Board.....	2-21
2.3.7	Connections to the COM3 (RS-485/RS-232) Serial Port on the CPU/System Controller Board	2-26
2.3.8	Connections to the Ethernet Port on the CPU/System Controller Board.....	2-28
2.4	Radios and Modems	2-29
2.5	Optional Display/Keypads	2-29

Chapter 3 – I/O Configuration and Wiring 3-1

3.1	I/O Options	3-1
3.2	Process I/O Board.....	3-2
3.2.1	Setting Jumpers on the Process I/O Board.....	3-2
3.2.2	Setting DIP Switches on the Process I/O Board.....	3-2
3.3	I/O Wiring	3-4
3.3.1	Non-Isolated Discrete Inputs (DI) on TB2 and TB3 of Process I/O Board.....	3-6
3.3.2	Non-Isolated Discrete Outputs (DO) on TB3 of Process I/O Board.....	3-7
3.3.3	Non-Isolated Analog Inputs (AI) on TB6 of Process I/O Board.....	3-8
3.3.4	Non-Isolated Analog Output (AO) on TB7 of Process I/O Board.....	3-9
3.3.5	Non-Isolated Pulse Counter/Discrete Inputs on TB5 of CPU/System Controller Bd ..	3-10
3.3.6	Non-Isolated High Speed Counter/ Discrete Inputs on TB4 of Process I/O Bd.....	3-11
3.3.7	Resistance Temperature Device (RTD) Inputs on CPU/System Controller Board.....	3-12
3.3.8	Connections to a Bristol Model 3808 Transmitter	3-14

Chapter 4 – Operation 4-1

4.1	Powering Up/Powering Down the ControlWave ExpressPAC.....	4-1
4.2	Communicating with the ControlWave ExpressPAC	4-2
4.2.1	Default Comm Port Settings.....	4-2
4.2.2	Collecting Data from the ControlWave ExpressPAC	4-2
4.3	Creating and Downloading an Application (ControlWave Project)	4-3

4.4	Creating and Maintaining Backups	4-3
4.4.1	Creating a Zipped Project File (*.ZWT) For Backup	4-4
4.4.2	Saving Flash Configuration Parameters (*.FCP)	4-5
4.4.3	Backing up Data.....	4-6

Chapter 5 – Service and Troubleshooting **5-1**

5.1	Upgrading Firmware.....	5-2
5.2	Removing or Replacing Components	5-5
5.2.1	Accessing Modules for Testing	5-5
5.2.2	Removing/Replacing the CPU/System Controller Board and the Process I/O Board ..	5-5
5.2.3	Removing/Replacing the Primary Battery System.....	5-6
5.2.4	Removing/Replacing the Backup Battery	5-7
5.2.5	Enabling / Disabling the Backup Battery.....	5-8
5.2.6	Removing/Replacing the Case-Mounted Radio or Modem	5-9
5.3	General Troubleshooting Procedures	5-9
5.3.1	Checking LEDs	5-9
5.3.2	Status Messages on LCD Display	5-10
5.3.3	WINDIAG Diagnostic Utility.....	5-11
5.3.4	Available Diagnostics.....	5-12
5.4	Core Updump	5-15
5.5	Calibration Checks	5-17

Appendix A – Special Instructions for Class I, Division 2 Hazardous Locations **A-1**

Appendix Z – Sources for Obtaining Material Safety Data Sheets (MSDS) **Z-1**

Index **IND-1**

Chapter 1 – Introduction

This manual focuses on the hardware aspects of the ControlWave[®] ExpressPAC Process Automation Controller/Remote Terminal Unit (RTU). For information about the software used with the ControlWave ExpressPAC, refer to *Getting Started with ControlWave Designer* (D5085), the *ControlWave Designer Programmer's Handbook* (D5125), and the online help in ControlWave Designer.

This chapter provides an overview of the ControlWave ExpressPAC and its components and details the structure of this manual

In This Chapter

1.1	Scope of the Manual.....	1-2
1.2	Physical Description	1-2
1.3	CPU/System Controller Board.....	1-4
1.4	Power Options	1-6
1.5	I/O Options.....	1-6
1.6	Software Tools.....	1-7

ControlWave ExpressPAC is designed to perform as the ideal platform for remote site automation, measurement, and data management in process control and manufacturing. It can serve as a process automation controller or remote terminal unit (RTU). Typical process inputs used by the ControlWave ExpressPAC are pressure, flow, level, temperature and frequency input [typically used for positive displacement (PD)], turbine, or ultrasonic meters. In some cases, inputs may also be derived from external multivariable transmitters using either the BSAP or Modbus protocols. Emerson provides the ControlWave ExpressPAC in a NEMA 3R rated enclosure which allows operation in an un-protected outdoor environment.

Features ControlWave ExpressPAC has the following key features:

- Exceptional performance and low power consumption through use of the ARM microprocessor
- Very low power consumption to minimize costs of integrated solar panel / battery power systems
- Three CPU / System Controller board configurations (see *Table 1-1*.)
- Three process I/O board configurations (see *Table 1-2*.)
- Two RS-232 and one RS-232/RS-485 asynchronous serial communication ports
- Optional 10/100 MB Ethernet port
- Broad selection of modem and wireless communication options
- Optional display or display/keypad

- Wide operating temperature range: (–40 to +70°C) (–40 to 158°F)
- Battery backup for Static RAM (SRAM) and real-time clock.
- Nonincendive Class I, Division 2 (Groups C and D) Hazardous Location approvals - See *Appendix A*.
- Cost-effective for small RTU/process controller applications.

1.1 Scope of the Manual

This manual contains the following chapters:

Chapter 1 Introduction	Provides an overview of the hardware and general specifications for the ControlWave ExpressPAC.
Chapter 2 Installation	Provides information on mounting the ControlWave ExpressPAC and setting CPU jumpers and switches.
Chapter 3 I/O Configuration	Provides general information on wiring the process I/O points.
Chapter 4 Operation	Provides information on day-to-day operation of the ControlWave ExpressPAC.
Chapter 5 Service and Troubleshooting	Provides information on service and troubleshooting procedures.

1.2 Physical Description

The ControlWave ExpressPAC includes the following major components:

- Enclosure with a local communication port and LCD display/keypad.
- CPU/System Controller Board (SCB) – See *Section 1.3*
- Optional process I/O board – See *Section 1.5*
- Internal mounting brackets and battery
- Optional RTD probe– See *Section 1.5*
- Radio/modem options

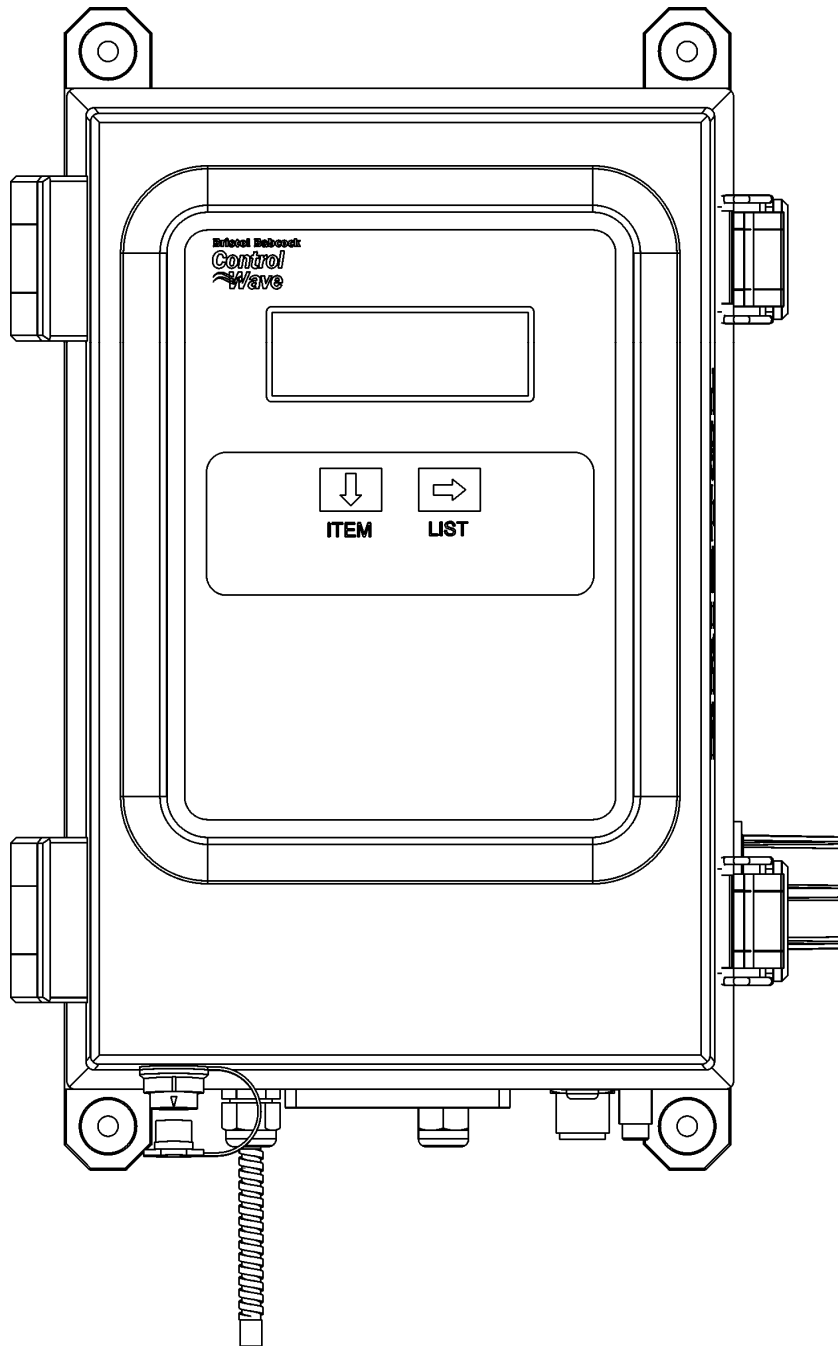

Figure 1-1. ControlWave ExpressPAC Enclosure shown with wall/panel mounting brackets and dual-button display/keypad

Enclosure The ControlWave ExpressPAC enclosure is a standard NEMA 3R rated fiberglass enclosure. The enclosure consists of the body and the front cover. A continuous gasket seals the unit when you close the front cover. Two latches on the enclosure's right side secure the cover. The enclosure includes a weatherproof connector (local port) mounted to the bottom of the cover and connected internally to RS-232 COM port 1.

The enclosure includes a display or display/keypad for an operator or technician to view process values locally.

Internal Mounting Brackets and Battery Internal mounting brackets support the various system components, such as the battery, CPU/System Controller and Process I/O boards, and the radio/modem option. These components attach to the one piece mounting bracket which is secured to the inner rear wall of the enclosure. A factory-supplied radio or modem mounts in front of the battery on a battery cover/radio mounting plate.

You can order the ControlWave Express from the factory with one of the following power options:

- Single 6V lithium battery
- Dual 12V lithium battery pack
- 6V, 7AH lead acid battery used with a 1W, 6V solar panel.
- 6V, 7AH lead acid battery used with a 5W, 6V solar panel.
- 12V, 7AH lead acid battery used with a 5W, 12V solar panel.
- No battery; user-supplied power source.

Radio/Modem You can order the ControlWave ExpressPAC with a factory-installed modem or spread spectrum radio. The unit supports a variety of MDS and FreeWave radios and modems. Contact Emerson Remote Automation Solutions for more information.

1.3 CPU/System Controller Board

The CPU (central processing unit) and System Controller Board (SCB) contains the ControlWave ExpressPAC CPU, I/O monitor/control, memory, and communication functions.

The CPU/System Controller board includes:

- Sharp LH7A400 System-on-Chip ARM microprocessor with 32-bit ARM9TDMI Reduced Instruction Set Computer (RISC) core, with a system clock speed of either 14 MHz or 33 MHz.
- two RS-232 communication ports
- one communication port configurable by jumpers as either RS-232 or RS-485
- optional 10/100baseT Ethernet port (See *Table 1-1*)
- 2 MB of battery backed Static RAM (SRAM),

- 512KB boot/downloader FLASH,
- 8MB simultaneous read/write FLASH memory

Board Variations The CPU/System Controller board has three basic variations:

Table 1-1. CPU/System Controller board Variations

CPU	Nominal Input Power	Ethernet Port?	Solar Regulator ?	Auxiliary Power Output?	RTD Input?
14MHz ultra low power	+6Vdc or +12Vdc	No	Yes	Yes	Yes. Connects to 100-ohm platinum bulb. Uses DIN 43760 curve.
33MHz low power	+12V or +24Vdc	No	Yes	Yes	No
33MHz	+12V or +24Vdc	Yes	No	No	Yes (same as ultra low power)

Note: Each of the variants shown in *Table 1-1* may be ordered with or without special gas calculation firmware.

CPU Backup Battery The CPU/System Controller board has a coin cell socket that accepts a 3.0V, 300 mA-hr lithium battery. This 3.0V battery provides backup power for the real-time clock and the system's Static RAM (SRAM).

CPU Memory There are several different types of memory used by the CPU:

Boot/Downloader FLASH

Boot/download code is contained in a single 512 Kbyte FLASH chip. Boot FLASH also holds the value of soft switches, audit/archive file configurations, and user account and port information.

FLASH Memory

The ControlWave ExpressPAC includes 8 MB of FLASH memory. The FLASH memory holds the system firmware and the boot project. Optionally FLASH memory also stores the zipped ControlWave project (*.zwt), user files, and historical data (audit/archive files). The FLASH does not support hardware write protection.

System Memory (SRAM)

The ControlWave ExpressPAC has 2 MB of static random access memory (SRAM). During power loss periods, SRAM enters data

retention mode (powered by a backup 3.0V lithium battery). Critical system information that must be retained during power outages or when the system has been disabled for maintenance is stored here. This includes the last states of all I/O points, audit/archive historical data (if not stored in FLASH), the values of any variables marked RETAIN, the values of any variables assigned to the static memory area, and any pending alarm messages not yet reported.

1.4 Power Options

You can power the ControlWave ExpressPAC by:

- factory-supplied rechargeable 6/12V lead acid battery (used in conjunction with a solar panel),
- factory-supplied single or dual lithium battery pack
- user-supplied bulk (nominal +6Vdc, +12Vdc or +24Vdc) power supply.

If you connect solar panels to rechargeable battery systems to power the ControlWave ExpressPAC, there is a secondary power input you can use to provide power if there is no power from the solar panel/battery system.

1.5 I/O Options

ControlWave ExpressPAC comes with the following standard I/O

- 2 Pulse Counter Inputs with a 1 second scan rate (can be configured as discrete inputs (DI))
- The 14 MHz CPU and 33 MHz CPU with Ethernet also include a Resistance Temperature Device (RTD) probe.

In addition, three different versions of the optional process I/O board are available:

Table 1-2. Process I/O Configurations

Type	Discrete Input / Output (DI/DO)	Discrete Input (DI)	Discrete Output (DO)	High Speed Counter (HSC)	Analog Input (AI)	Analog Output (AO)
A	2	4	2	2		
B	2	4	2	2	3	
C	2	4	2	2	3	1

1.6 Software Tools

The ControlWave programming environment consists of a set of integrated software tools which allow you to create, test, implement, and download complex control strategies for use with the ControlWave ExpressPAC. *Figure 1-2* graphically presents the programming environment.

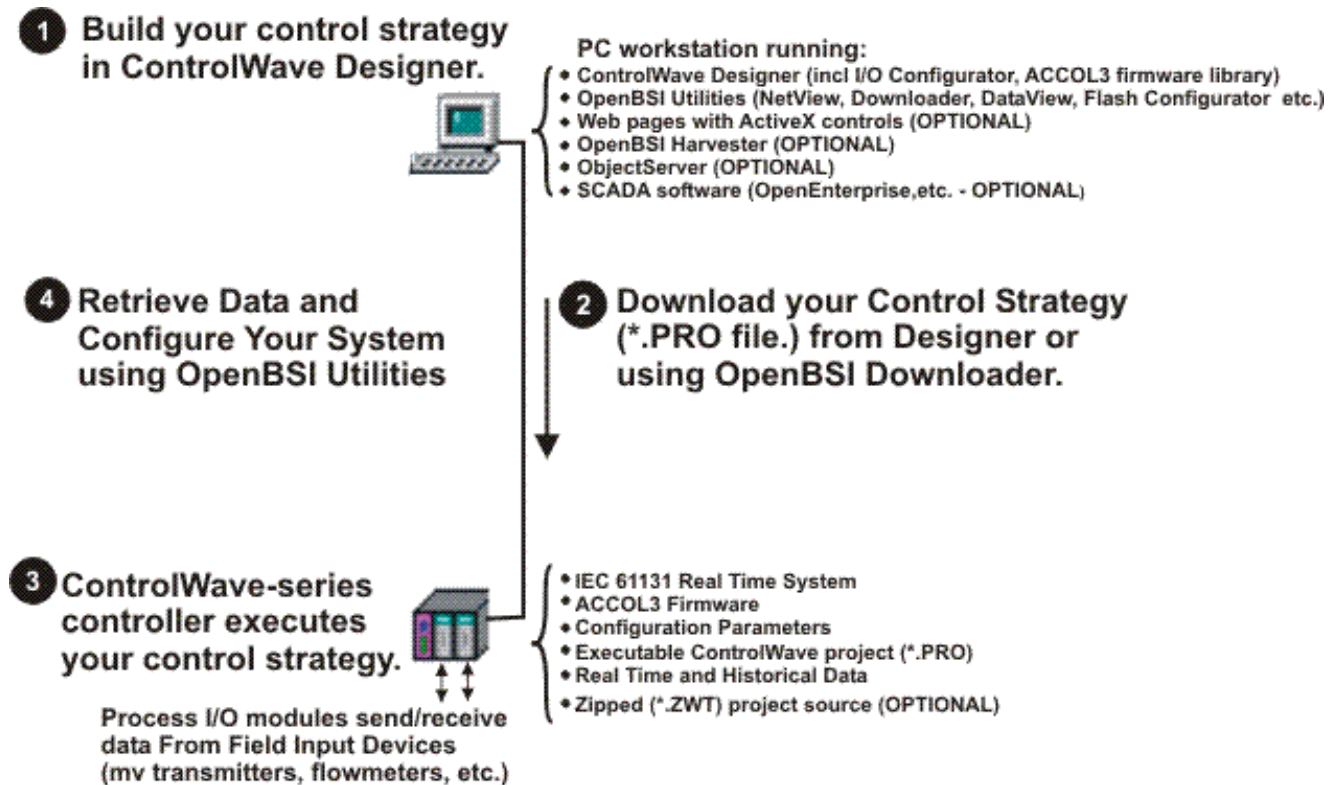

Figure 1-2. ControlWave Programming Environment

The tools which make up the programming environment include:

- **ControlWave Designer** is your load-building package. It offers several different methods for you to create control strategy programs that run in your ControlWave ExpressPAC. You can use pre-made function blocks, ladder logic, or structured languages. The resulting process control strategy programs (called **projects**) are fully compatible with **IEC 61131** standards. For information on ControlWave Designer, see the *Getting Started with ControlWave Designer* manual (document D5085), and the *ControlWave Designer Programmer's Handbook* (document D5125).
- The **I/O Configurator**, accessible via a menu item in ControlWave Designer, allows you to define process I/O in the ControlWave and configure the individual mapping of I/O points for discrete and analog inputs and outputs. For information on the I/O Configurator see the *ControlWave Designer Programmer's Handbook* (document D5125).

- The **ACCOL3 Firmware Library**, available within ControlWave Designer, includes a series of ControlWave-specific function blocks. These pre-programmed function blocks let you accomplish various tasks common to most user applications including alarming, historical data storage, as well as process control algorithms such as PID control. For information on individual function blocks, see the online help within ControlWave Designer.
- **OpenBSI Utilities** provides a set of programs that allow you to configure a communication network of ControlWave controllers, download files to the controllers, and collect data from the network. OpenBSI also exports data from the network to a SCADA/host package, such as **OpenEnterprise**. For information on configuring OpenBSI communications, see the *OpenBSI Utilities Manual* (document D5081).
- **OpenBSI Harvester** is a special add-on package that allows scheduled data collections from large networks. For information on the Harvester, see the *OpenBSI Harvester Manual* (document D5120).
- A series of **web page controls** are available for retrieval of real-time data values and communication statistics. These controls utilize ActiveX technology and are called through a set of fixed web pages, compatible with Microsoft® Internet Explorer. Alternatively, developers can place the controls in third-party ActiveX compatible containers such as Visual BASIC or Microsoft® Excel. For information on the ActiveX controls, see the *Web_BSI Manual* (document D5087).
- **User-defined web pages** - If desired, you can use the ActiveX web controls in your own user-defined web pages you can store at the PC to provide a customized human-machine interface (HMI).
- **Flash Configuration Utility** – Parameters such as the BSAP local address, IP address, etc. are set using the Flash Configuration Utility, accessible via OpenBSI LocalView, NetView, or TechView. For information on the Flash Configuration Utility, see *Chapter 5* of the *OpenBSI Utilities Manual* (document D5081).

Communication Protocols In addition to the **Bristol Synchronous/Asynchronous Protocol (BSAP)**, ControlWave supports communications using:

Internet Protocol (IP) - You can use an Ethernet port or use a serial port with serial IP using **Point-to-Point Protocol (PPP)**.

Other supported protocols include: Modbus, Allen-Bradley DF1, CIP, DNP3, and Hex Repeater. See the ControlWave Designer online help for details and restrictions.

Chapter 2 – Installation

This chapter discusses the physical configuration of the ControlWave ExpressPAC, considerations for installation, and instructions for setting switches and jumpers.

In This Chapter

2.1	Site Considerations.....	2-1
2.1.1	Class I, Div 2 Installation Considerations.....	2-3
2.2	Installation Overview.....	2-3
2.2.1	Mounting the Housing	2-4
2.2.2	Grounding the Housing	2-9
2.3	Configuring the CPU/System Controller Board	2-10
2.3.1	Setting DIP Switches on CPU/System Controller Board.....	2-11
2.3.2	Setting Jumpers on the CPU/System Controller Board	2-13
2.3.3	General Wiring Guidelines	2-14
2.3.4	Wiring Power to the CPU/System Controller Board.....	2-14
2.3.5	Mounting the Solar Panel.....	2-18
2.3.6	Connections to RS-232 Serial Port(s) on the CPU/System Controller Board.....	2-21
2.3.7	Connections to the COM3 (RS-485/RS-232) Serial Port on the CPU/System Controller Board.....	2-26
2.3.8	Connections to the Ethernet Port on the CPU/System Controller Board	2-28
2.4	Radios and Modems.....	2-29
2.5	Optional Display/Keypads.....	2-29

2.1 Site Considerations

When choosing an installation site, check all clearances. Ensure that you can open the ControlWave ExpressPAC cover (hinged on the left side) for wiring and service. If present, make sure the optional display/keypad is accessible and visible. See *Figure 2-2* for a dimensional drawing of the NEMA enclosure.

Ensure adequate clearance for the solar panel (if required).

The ControlWave ExpressPAC comes in an enclosure/chassis that you can mount to a panel, a wall or a 2 inch vertical pipe. The ControlWave ExpressPAC is designed to operate in an outdoor un-protected Class I Division 2, Groups C & D environment with a nonincendive rating (see *Appendix A*).

Caution

To ensure safe use of this product, please review and follow the instructions in the following supplemental documentation:

- **Supplement Guide - ControlWave Site Considerations for Equipment Installation, Grounding, and Wiring (S1400CW)**
- **ESDS Manual – Care and Handling of PC Boards and ESD Sensitive Components (S14006)**

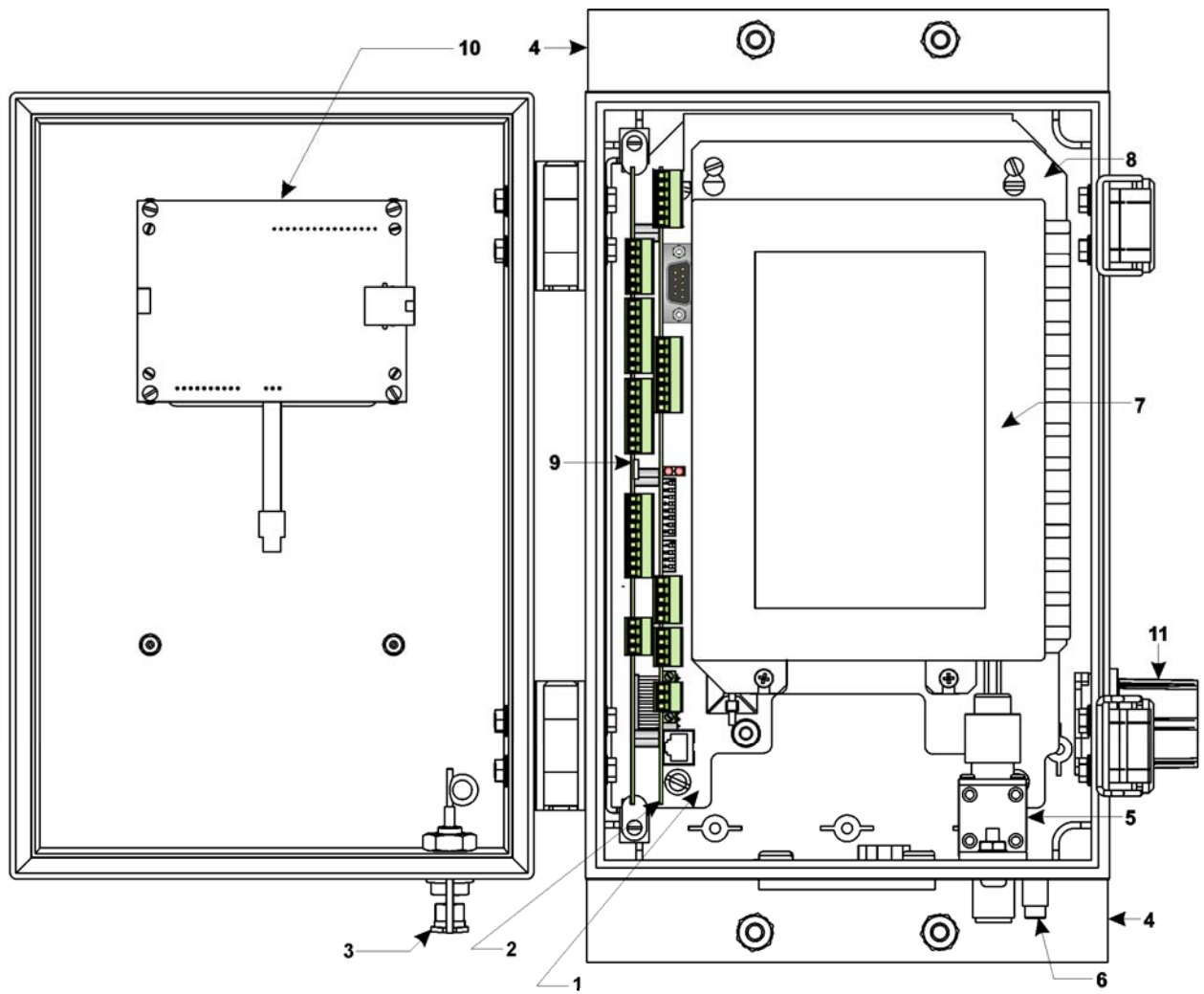

- | | |
|--|---------------------------------------|
| 1. One Piece/Battery Mounting Bracket | 7. External Radio (MDS - Transnet) |
| 2. CPU/System Controller Board (w LED Bd.) | 8. Radio/Modem Mounting Bracket |
| 3. Local Comm. Port Connector & Cover | 9. Process I/O Board |
| 4. Rear Pipe Mounting Bracket (Qty. 2) | 5. Optional Polyphaser |
| 5. Optional Polyphaser | 11. 3/4" Conduit Fitting (I/O Wiring) |
| 6. Ground Lug | |

Figure 2-1. ControlWave ExpressPAC Component Identification

**Specifications
for Temperature,
Humidity and
Vibration**

- See document [420DS-7d](#) available on our website for detailed technical specifications for temperature, humidity, and vibration for the ControlWave ExpressPAC.
- Ensure that the ambient temperature and humidity at the installation site remains within these specifications. Operation beyond the specified ranges could cause output errors and erratic performance. Prolonged operation under extreme conditions could also result in failure of the unit.
- Check the mounted enclosure, panel, or pipe for mechanical vibrations. Make sure that the ControlWave ExpressPAC is not exposed to a level of vibration that exceeds that provided in the technical specifications.

2.1.1 Class I, Div 2 Installation Considerations

Underwriters Laboratories (UL) lists the ControlWave ExpressPAC as non-incendive and suitable **only** for use in Class I, Division 2, Groups C, and D hazardous locations and non-hazardous locations. Read this chapter and *Appendix A* carefully before you install a ControlWave ExpressPAC in a hazardous location.

Perform all power and I/O wiring in accordance with Class I, Division 2 wiring methods as defined in *Article 501-4 (b)* of the *National Electrical Code, NFPA 70* (for installations within the United States) or as specified in *Section 18-152* of the *Canadian Electrical Code* (for installation in Canada).

**WARNING EXPLOSION HAZARD**

Substitution of components may impair suitability for use in Class I, Division 2 Groups C and D environments.

When the ControlWave ExpressPAC is situated in a hazardous location, turn off power before servicing or replacing the unit and before installing or removing I/O wiring.

Do not disconnect equipment unless the power is switched off or the area is known to be non-hazardous.

2.2 Installation Overview

ControlWave ExpressPAC ships from the factory with all components wired and mounted, except for the unit's solar panel and primary battery; these items are shipped separately.

Installing a ControlWave ExpressPAC involves several general steps:

1. Installing and configuring the hardware. This includes:
 - a) Mounting the chassis on a panel, wall, or vertical pipe. (See *Section 2.2.1*)

- b) Enabling the backup battery by setting jumper W3 on the CPU/System Controller board to position 1 to 2. (See *Section 2.3.2*)
 - b) Setting switches and jumpers on the CPU/System Controller board (see *Section 2.3.1* and *Section 2.3.2*) and on the Process I/O board (see *Section 3.2.1* and *Section 3.2.2*) and placing both boards (as a single assembly) into the chassis.
 - d) Connecting communication cables, including a cable to a 3808 transmitter, if required. (See *Sections 2.3.6, 2.3.7, 2.3.8, and 3.3.8.*)
 - e) Wiring I/O. (See *Section 3.3*)
 - f) Installing a ground wire between the enclosure ground lug and a known good Earth ground. (See *Section 2.2.2*)
 - g) Connecting the RTD probe (if required). (See *Section 3.3.7*)
 - h) Installing the solar panel and rechargeable battery (if applicable).(See *Section 2.3.5*)
 - i) Wiring power to the unit. (See *Section 2.3.4*)
 - j) Turning on power. (See *Section 4.1*)
2. Installing PC-based software (ControlWave Designer).
 3. Establishing communications.
 4. Creating an application-specific control strategy (ControlWave project).
 5. Creating application-specific web pages (optional).
 6. Adding the ControlWave ExpressPAC to an OpenBSI network.
 7. Downloading the application-specific ControlWave project into the ControlWave ExpressPAC.

Note: Steps 2 through 7 require that you install and use ControlWave Designer software on your PC. This manual focuses on hardware installation and preparation. Software installation and configuration is beyond the scope of this manual. Refer to the *Getting Started with ControlWave Designer Manual (D5085)* and the *ControlWave Designer Programmer's Handbook (D5125)* for material related to software installation and use.

2.2.1 Mounting the Housing

- You must position the ControlWave ExpressPAC vertically. See *Figure 2-2* for enclosure dimensions.
- Make sure the front of the assembly is visible and you can open the front cover for service, installation, and so on. Ensure you can clearly see and use the optional LCD display/keypad.

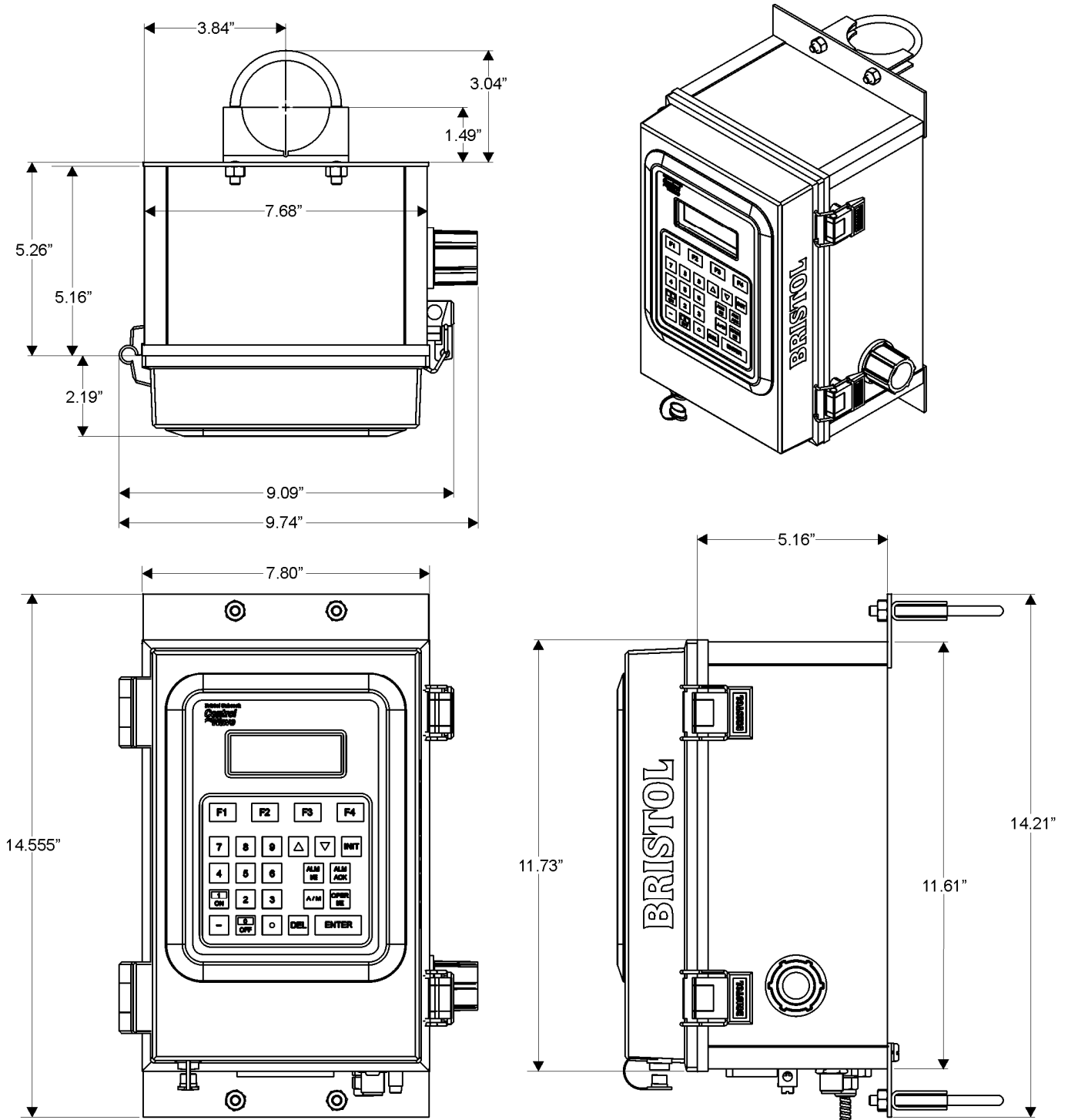

Figure 2-2. ControlWave ExpressPAC NEMA 3R Enclosure Dimensions

- Mount the unit to a panel, a wall or to a vertical 2 inch pipe clamped at the rear of the unit using two clamps and four bolts. See *Figure 2-4* and *Figure 2-5*. If you mount to a pipe, it must be anchored in cement deep enough to conform to local building codes associated with frost considerations.

- If your unit requires a solar panel, you can mount it to the same 2 inch pipe that holds the controller. Make sure there is adequate clearance for the solar panel. For more information on the solar panel, see *Section 2.3.5*.
- Only connect power wiring after the unit is mounted and properly grounded.
- I/O wiring, external power wiring, RTD wiring, antenna cabling, and communication port cabling enters the bottom of the unit through conduit or special function fittings. (See *Figure 2-3*.) I/O wiring is routed through the left side of the unit (right when facing the front) via a 3/4 inch conduit fitting.

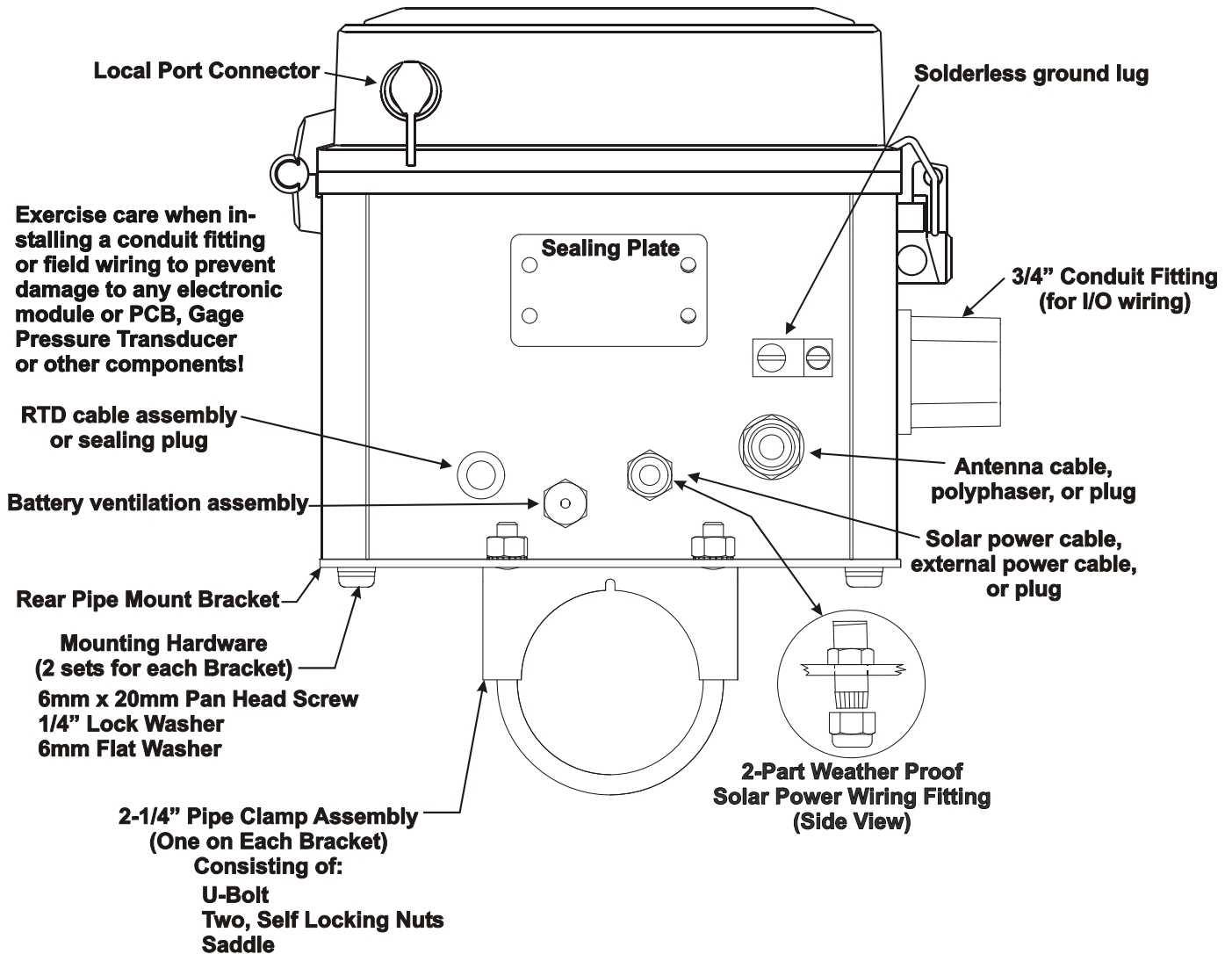

Figure 2-3. ControlWave ExpressPAC Bottom View

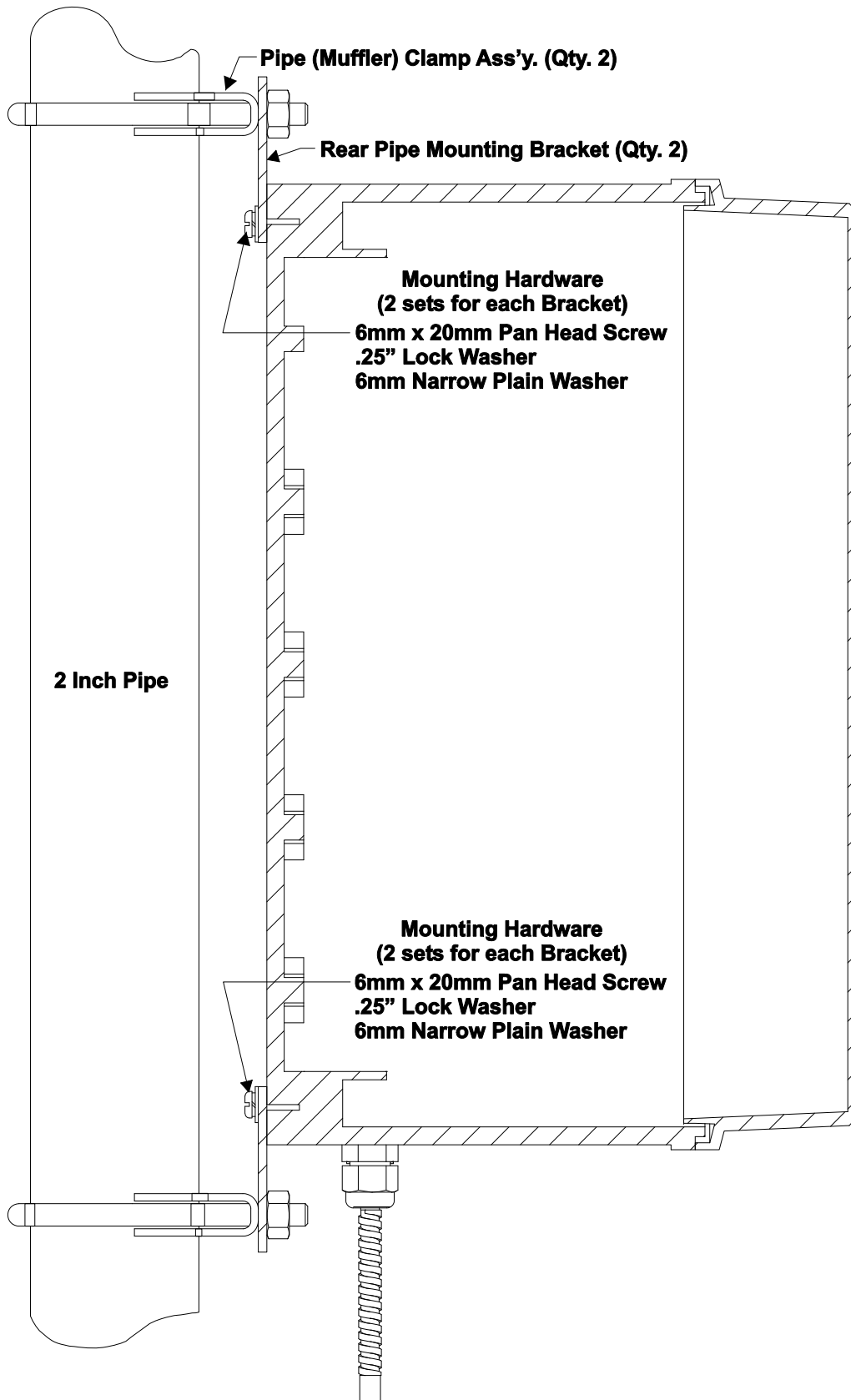

Figure 2-4. Side View of ControlWave ExpressPAC (Mounted to a 2" Pipe)

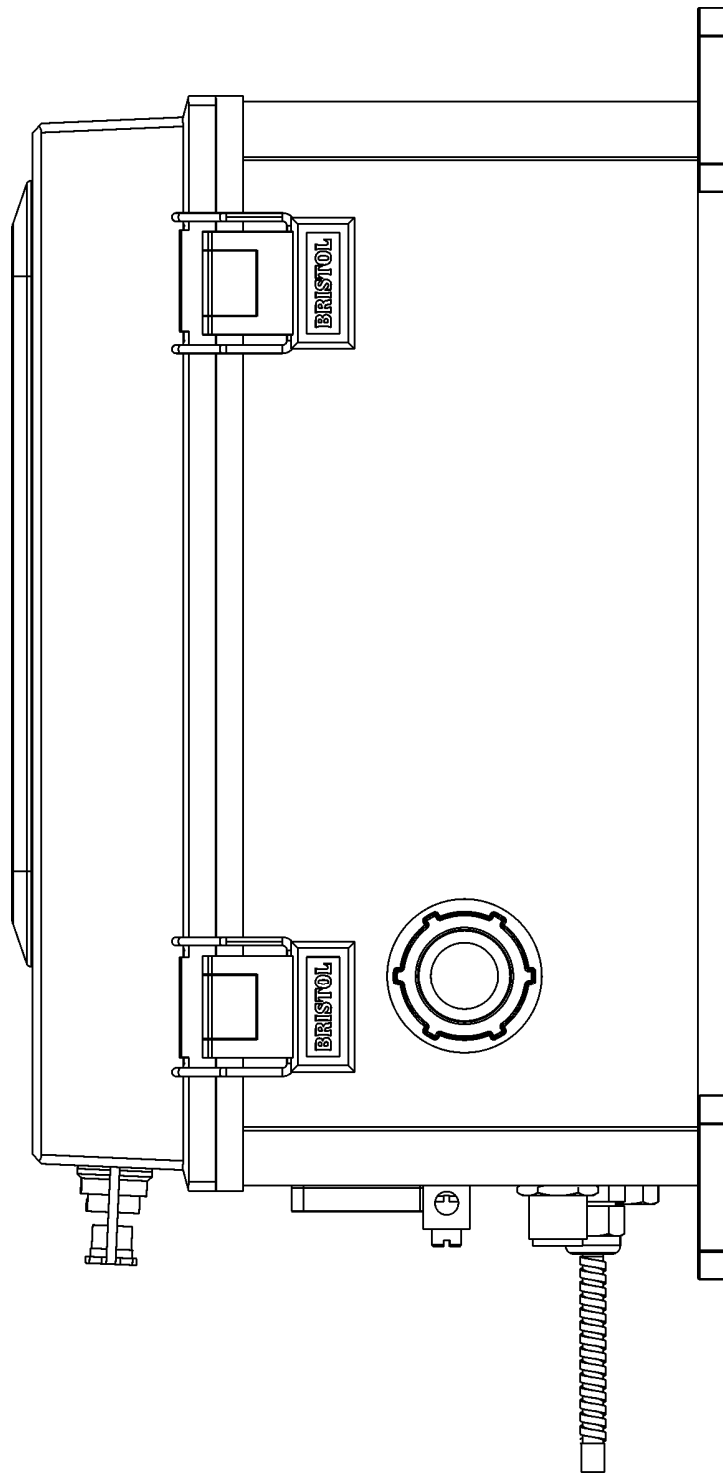

Figure 2-5. Side View of ControlWave ExpressPAC (Wall or Panel Mounted)

2.2.2 Grounding the Housing

The ControlWave ExpressPAC enclosure includes a ground lug that accommodates up to a #4 AWG wire size. Once you install the unit, run a ground wire between the enclosure's ground lug and a known good Earth ground. For more information on grounding see the *ControlWave Grounding Supplement (S1400CW)*:

Additional grounding guidelines include:

- Use stranded copper wire (#4 AWG) to earth ground, and keep the length as short as possible.
- Clamp or braze the ground wire to the ground bed conductor (typically a stranded copper AWG 0000 cable installed vertically or horizontally).
- Using a high-wattage soldering iron, tin the ground wire with solder before you insert it into the chassis ground.
- Run the ground wire so that any routing bend in the cable has a minimum radius of 12-inches below ground and 8-inches above ground.

2.3 Configuring the CPU/System Controller Board

To configure the CPU/System Controller board, you need to set some switches and jumpers.

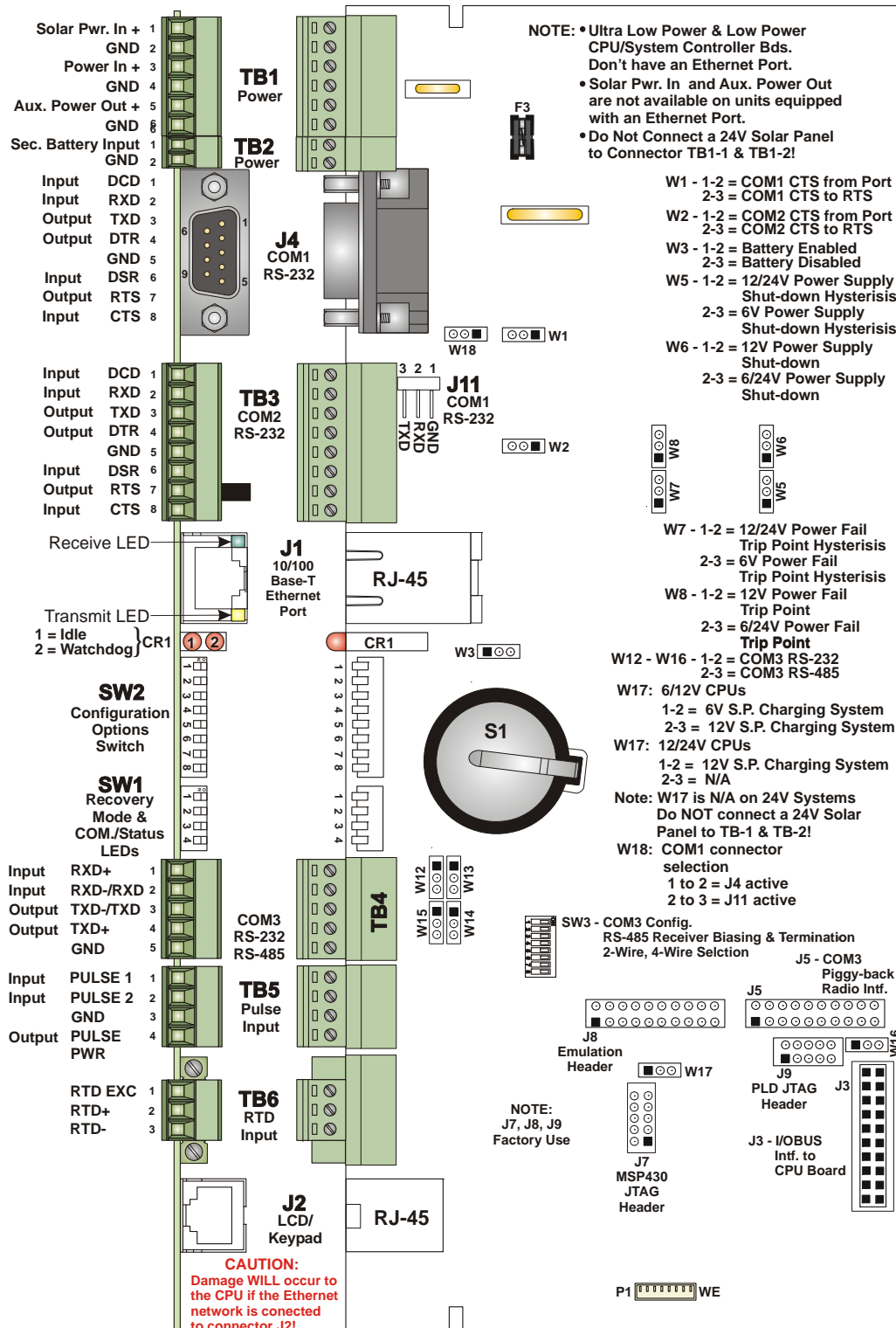

Figure 2-6. - CPU/System Controller Board Component I.D. Diagram

2.3.1 Setting DIP Switches on the CPU/System Controller Board

Before you install the CPU/System Controller board, you must determine the settings for three banks of DIP switches. Refer to *Figure 2-6* for the location of the DIP switch banks. Refer to *Tables 2-1, 2-2, and 2-3* for an explanation of the DIP switch positions.

Note: Examine each bank of DIP switches carefully to note the switch direction for ON or OFF.

Table 2-1. CPU/System Controller Board Switch SW1

SW1 Setting	Function	Mode
1 & 2	Recovery Mode	Recovery Mode = Both SW1-1 and SW1-2 ON or both SW1-1 and SW1-2 OFF Local Mode = SW1-1 OFF and SW1-2 ON (Factory Default)
3	Force Recovery Mode	Enables recovery mode. Values are: ON (enables recovery mode) OFF (disables recovery mode). – This is the factory default .
4	LED status	ON (Enable Idle LED) OFF (Disable Idle LED)

Table 2-2. CPU/System Controller Board Switch SW2

SW2 Setting	Function	Mode
1	Watchdog Enable	Controls whether the system enters a watchdog state when a crash or system hangup occurs and automatically restarts. Values are: ON (Enables watchdog circuit; factory default) OFF (Disables watchdog circuit and prevents automatic restart)
2	Lock/Unlock Soft Switches	Controls the ability to modify soft switches, other configurations, and flash files. Values are: ON (Unlocks soft switches and flash files; factory default). OFF (Locks soft switches, configurations, and flash files)
3	Use/Ignore Soft Switches	Controls the use of soft switches. Values are: ON (Enable user-defined soft switches configured in flash memory; factory default) OFF (Disable soft switch configuration and use factory defaults) Note: Setting both switch 3 and switch 8 to OFF (closed) sets all serial communication ports to 9600 bps operation. All serial communication ports must be set at 9600 bps before WINDIAG can perform communication tests.
4	Core Updump	Causes the ControlWave ExpressPAC to perform a core updump, provided you have set the SW1 switches to allow recovery mode. Values are:

SW2 Setting	Function	Mode
		ON (Disables core updump; factory default) OFF Core updump
5	SRAM Control	Manages SRAM contents following a low power situation or a power outage. Values are: ON (Retain values in SRAM during restarts; factory default) OFF (Reinitialize SRAM) – Data in SRAM lost during power outage or re-start.
6	System Firmware	Allows a remote download of system firmware (on units equipped with boot PROM version 4.7 or higher and system PROM version 4.7 and higher). Values are: ON (Enable remote download of system firmware; factory default) OFF (Disable remote download of system firmware)
7	N/A	Not currently used.
8	Enable WINDIAG	Suspends normal operation and allows diagnostic routines. Values are: ON (Permits normal system operation, including the boot project, and disables the WINDIAG diagnostics from running; factory default) OFF (Allow WINDIAG to run test; disable boot project and normal system operation.) Note: Setting both switch 8 and switch 3 to OFF (closed) sets all communication ports to 9600 bps operation. All serial communication ports must be set at 9600 bps before WINDIAG can perform communication tests.

Note: *Table 2-3* describes switch settings for RS-485 port operation. You may want to review *Section 2.3.7* on RS-485 configuration before you set these switches.

Table 2-3. RS-485 Configuration Switch SW3

Switch Setting	Function	Mode
1	TX+ to RX+ Loopback / 2-wire	ON (2-wire operation or loopback enabled) OFF (4-wire operation and loopback disabled)
2	TX- to RX- Loopback / 2-wire	ON (2-wire operation or loopback enabled) OFF (4-wire operation and loopback disabled)
3	100 Ohm RX+ Termination	ON (End nodes only)
4	100 Ohm RX- Termination	ON (End nodes only)
5	N/A	Not currently used
6	N/A	Not currently used

Switch Setting	Function	Mode
7	RX+ Bias (End Node)	ON (4-wire = Both End nodes only; 2-wire= One end node only) OFF = No bias
8	RX- Bias (End Node)	ON (4-wire = Both End nodes only; 2-wire= One end node only) OFF = No bias

2.3.2 Setting Jumpers on the CPU/System Controller Board

The CPU has several jumpers.

- **W1:** COM1 CTS usage:
 - 1-to-2 Installed = COM1 CTS source is from device.
 - 2-to-3 Installed = COM1 RTS to CTS loopback
- **W2:** COM2 CTS usage:
 - 1-to-2 Installed = COM2 CTS source is from device.
 - 2-to-3 Installed = COM2 RTS to CTS loopback

Note: You must enable the backup battery by setting jumper W3 to position 1-2.

- **W3:** Enable/disable battery backup selection:
 - 1-to-2 Installed = Enable battery backup.
 - 2-to-3 Installed = Disable battery backup
- **W5:** Power supply shut down selection:
 - 1-to-2 Installed = 12/24V power supply shut down hysteresis
 - 2-to-3 Installed = 6V power supply shut down hysteresis
- **W6:** Power supply shut down selection:
 - 1-to-2 Installed = 12V power supply shut down
 - 2-to-3 Installed = 6/24V power supply shut down
- **W7:** Power fail trip point hysteresis selection:
 - 1-to-2 Installed = 12/24V power fail trip point hysteresis
 - 2-to-3 Installed = 6V power fail trip point hysteresis
- **W8:** Power fail trip point selection:
 - 1-to-2 Installed = 12V power fail trip point
 - 2-to-3 Installed = 6/24V power fail trip point
- **W12:** COM3 configuration selection:
 - 1-to-2 Installed = COM3 is RS-232
 - 2-to-3 Installed = COM3 is RS-485
- **W13:** COM3 configuration selection:
 - 1-to-2 Installed = COM3 is RS-232
 - 2-to-3 Installed = COM3 is RS-485

- **W14:** COM3 configuration selection:
 - 1-to-2 Installed = COM3 is RS-232
 - 2-to-3 Installed = COM3 is RS-485
- **W15:** COM3 configuration selection:
 - 1-to-2 Installed = COM3 is RS-232
 - 2-to-3 Installed = COM3 is RS-485
- **W16:** COM3 configuration selection:
 - 1-to-2 Installed = COM3 is RS-232
 - 2-to-3 Installed = COM3 is RS-485
- **W17:** Input power selection (controls solar power shunt regulation. Not applicable for +24Vdc CPUs):
 - 1-to-2 Installed = 6V power
 - 2-to-3 Installed = 12V power
- **W18:** COM1 connector selection:
 - 1-to-2 Installed = connector J4 (D connector) is active
 - 2-to-3 Installed = alternate connector J11 is active

2.3.3 General Wiring Guidelines

- ControlWave ExpressPAC terminal blocks use compression-type terminals that accommodate up to #16 AWG wire.
- When making a connection, insert the bare end of the wire (approx ¼” max) into the clamp adjacent to the screw and secure the screw.
- To prevent shorts, ensure that no bare wire is exposed. If using standard wire, tin the bare end with solder to prevent flattening and improve conductivity.
- Allow some slack in the wire while making terminal connections. Slack makes the wires more manageable and helps minimize mechanical strain on the terminal blocks.

2.3.4 Wiring Power to the CPU/System Controller Board

You can power the ControlWave ExpressPAC by:

- factory-supplied 6V lithium battery
- factory-supplied 12V lithium battery pack (dual lithium batteries)
- factory-supplied 6V, 7AH lead acid battery – used with a 1W, 6V solar panel system
- factory-supplied 6V, 7AH lead acid battery – used with a 5W, 6V solar panel system
- factory-supplied 12V, 7AH lead acid battery – used with a 5W, 12V solar panel system
- user-supplied bulk (nominal +6Vdc, +12Vdc or +24Vdc) power supply.

If you connect solar panels to rechargeable battery systems to power the ControlWave ExpressPAC, there is a secondary power input you can use to provide power if there is no power from the solar panel/battery system.

**Caution**

At this time you can connect power wiring. However; for safety reasons and to prevent accidental damage to your bulk DC power supply, do not connect the pluggable terminal block connectors TB1 and TB2 to the CPU/System Controller board until after you install, wire, ground, and configure the entire unit.

Follow the instructions in *Section 2.3.3 General Wiring Guidelines* when wiring connections.

**Power Supply
Current
Requirements**

Depending upon the CPU type, the ControlWave ExpressPAC accepts either a 6Vdc, 12Vdc or 24Vdc bulk power input. You can estimate the maximum current required for your ControlWave ExpressPAC using the following equation:

$$\text{Bulk +6/12/24 Vdc Supply Current} = \text{CPU/System Controller Board (with options) + Process I/O Board + LCD display/keypad + optional external modem/radio}$$

Refer to *Table 2-4* for ControlWave ExpressPAC power requirements based on the CPU type.

Table 2-4. ControlWave ExpressPAC Bulk Power Requirements

CPU Type and Components	Bulk 6Vdc Power Supply	Bulk 12Vdc Power Supply	Bulk 24Vdc Power Supply
14 MHz Ultra Low Power CPU with LCD display/keypad	7 mA	without field supply and with AO output under range: 5 mA	Not Supported
33 MHz Low Power CPU without Ethernet, but with LCD display/keypad	Not Supported	without process I/O board: 14 mA	without process I/O board: 14 mA
33 MHz CPU with Ethernet and LCD display/keypad	Not Supported	without process I/O board: 80 mA	without process I/O board: 47 mA

Note: This summation accommodates steady state current draw and is based on typical application loads. For 3808 power consumption, see the 3808 manual (*CI-3808*). If your ControlWave ExpressPAC includes a modem or radio, contact the radio/modem manufacturer for power consumption specifications.

**Caution**

If your ControlWave ExpressPAC is configured to use a solar panel to charge a 7AH (6V or 12V) battery for power, NEVER CONNECT THE SOLAR PANEL/CHARGER WITHOUT ALSO CONNECTING THE

BATTERY. Connections without the battery present can damage power supply components.

Terminal Block Connector TB1

Unplug removable connector TB1 from the CPU/System Controller board. We recommend you do **not** plug the connector back into the CPU until the unit is already installed in the housing.

You can power low powered versions of the ControlWave ExpressPAC using a solar panel connected to a factory-installed rechargeable 7AH (6V/12V) lead acid battery at connections TB1-1 and TB1-2.

Alternatively, a factory-installed lithium battery/battery pack or a user-supplied bulk power supply connects to TB1-3 and TB1-4.

TB1 connections are:

- TB1-1: (Solar Power IN+): Power from a 1W – 6V, 5W – 6V or 5W – 12V solar panel (internally wired to recharge a factory-supplied internal battery). **Not available on units with Ethernet.**
- TB1-2 = Ground (GND). (GND = -)
- TB1-3 = Primary Power: Power from an internal factory-supplied battery or a nominal +6Vdc , +12Vdc or +24Vdc external power supply, depending upon the CPU type. Refer to the model specification when ordering the type of battery.
- TB1-4 = Ground (GND)
- TB1-5 = Auxiliary Power Out+: for an optional factory-installed radio or modem (if supported). COM2 DTR high enables the aux. power output. **Note: Aux. Power Out is not available on units with Ethernet.**
- TB1-6 = Ground (GND) for Aux power out.

Figure 2-7 shows the typical wiring at the TB1 block.

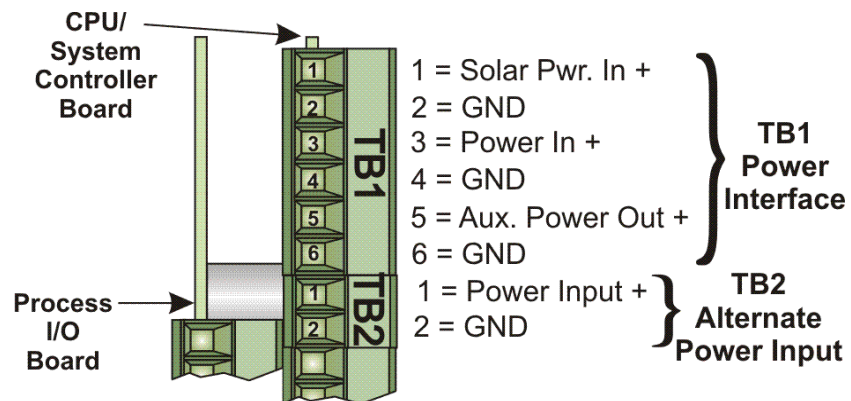

Figure 2-7. CPU/System Controller Board (TB1 & TB2) Power Wiring

If you power the ControlWave ExpressPAC using a bulk DC power supply use connections TB1-3 and TB1-4.

Nominal input source operating ranges for the DC power supply are:

- +6Vdc (+5.4Vdc to +16.0Vdc nominal operating range)
- +12Vdc (+11.4Vdc to +16.0Vdc nominal operating range)
- +24Vdc (+21.8Vdc to +28.0Vdc nominal operating range)

Not all ControlWave ExpressPAC CPUs support all DC power supplies. Supported options are:

- 14MHz Ultra Low Power CPU: Supports +6Vdc or +12Vdc nominal power supply.
- 33MHz Low Power CPU: Supports +12Vdc nominal or +24Vdc nominal power supply.
- 33MHz CPU with Ethernet: Supports +12Vdc nominal or +24Vdc nominal power supply.

Terminal Block Connector TB2

The ControlWave ExpressPAC includes an alternative power connector, TB2, to provide power if none is available at TB1. For example, you can connect a bulk DC power supply to TB2 to handle situations where the solar panel/battery does not have sufficient power.

TB2 connections are:

- TB2-1 = Power Input
- TB2-2 = Ground (GND)

2.3.5 Mounting the Solar Panel

Depending upon the type of power system you choose, your ControlWave ExpressPAC may require a solar panel. The solar panel charges a rechargeable 6V 7AH lead acid battery. Solar panel wires enter the unit through a liquid tight conduit fitting on the bottom of the enclosure and connect to TB1 on the CPU/System Controller board.

Caution

If your ControlWave ExpressPAC is configured to use a solar panel to charge a 7AH (6V or 12V) battery for power, NEVER CONNECT THE SOLAR PANEL/CHARGER WITHOUT ALSO CONNECTING THE BATTERY. Connections without the battery present can damage power supply components.

You can mount the solar panel to a 2" to 2-3/8" pipe using muffler (pipe) clamps. You secure the pipe clamps using four 1/4-20 nuts and washers. (See *Figure 2-8* and *Figure 2-9*.)

You must swivel the solar panel for optimum alignment with the sun. In the northern hemisphere, face the panel due south (not magnetic south). In the southern hemisphere, face the panel due north (not magnetic north).

1 and 5 watt solar panel systems have adjustable tilt angles. Adjust the tilt angle for maximum performance to accommodate the latitude of your installation site. *Table 2-5* shows the angle (from horizontal) at which you should install the solar panel to maximize annual energy output. At most latitudes, performance can be improved by less of an angle during the summer and more of an angle during winter.

Table 2-5. Solar Panel Tilt Angle

Latitude	Tilt Angle
0-4°	10° from Horizontal
5-20°	Add 5° to the Local Latitude
21-45°	Add 10° to the Local Latitude
46-65°	Add 15° to the Local Latitude
66-75°	80° from Horizontal

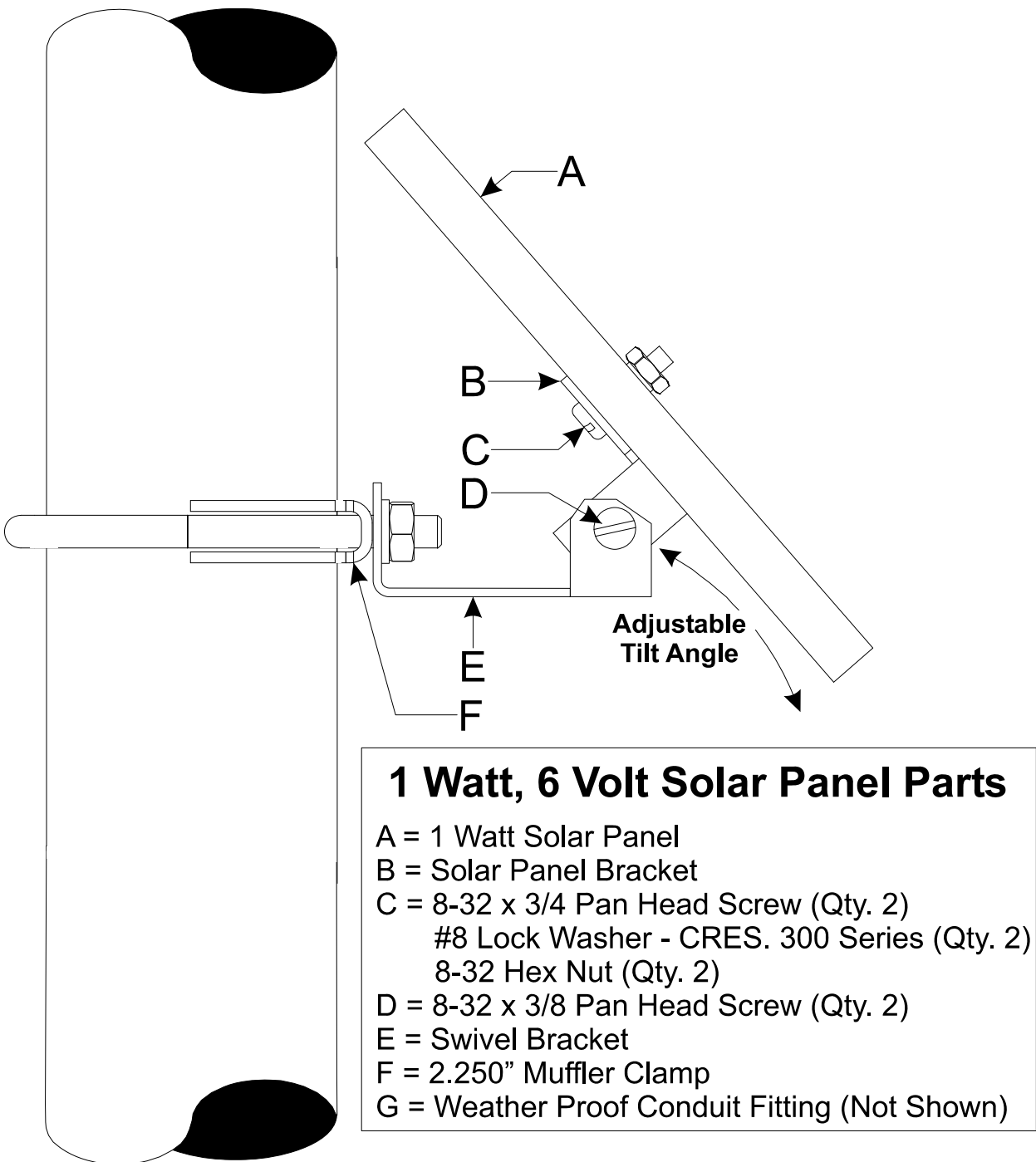
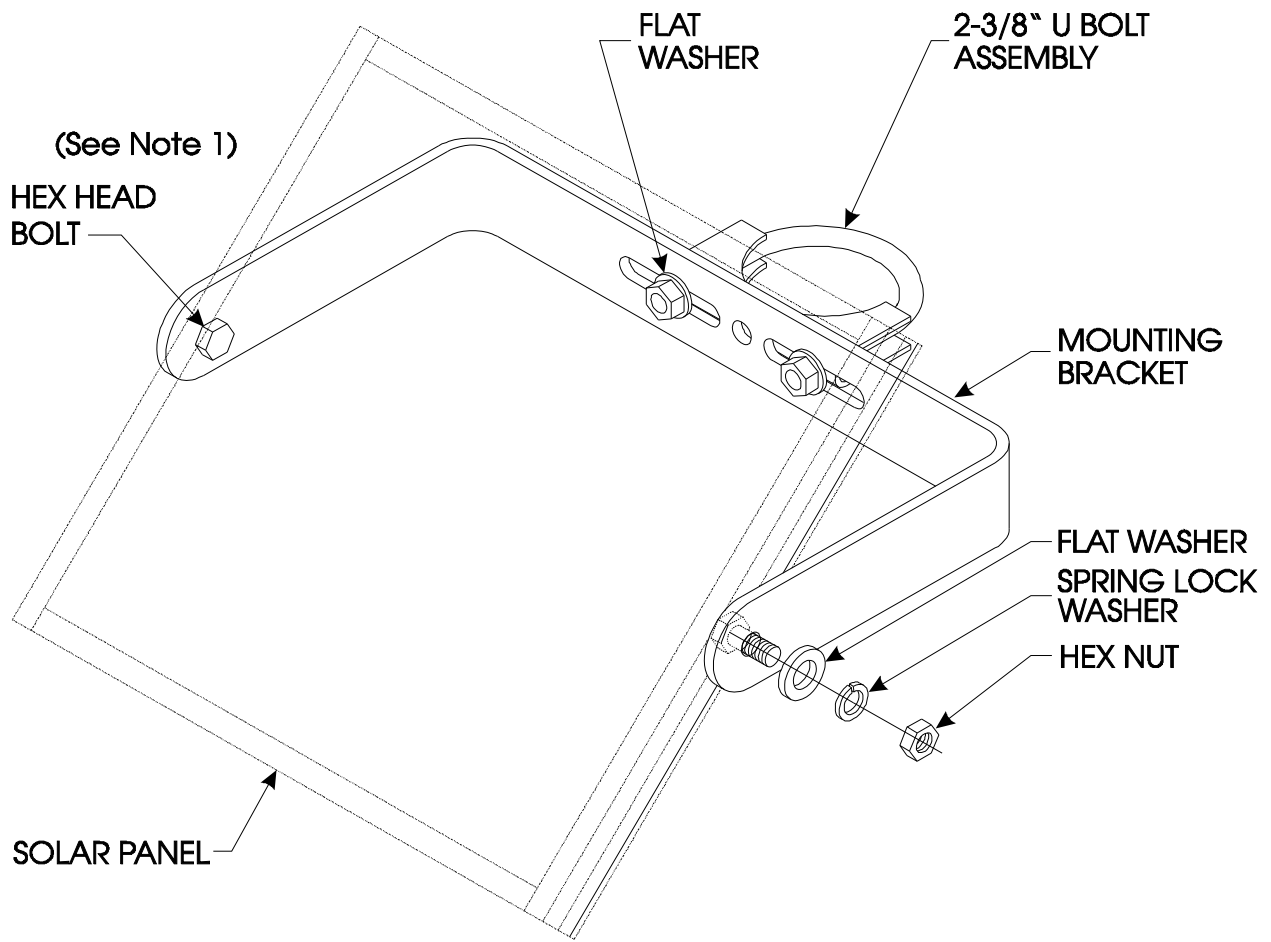

Figure 2-8. 1 Watt Solar Panel Mounting Diagram



NOTE 1:
SLIDE THE BOLT HEADS INTO THE CHANNELS IN THE SIDES OF THE SOLAR PANEL. MAX. TORQUE 125 INCH-POUNDS.

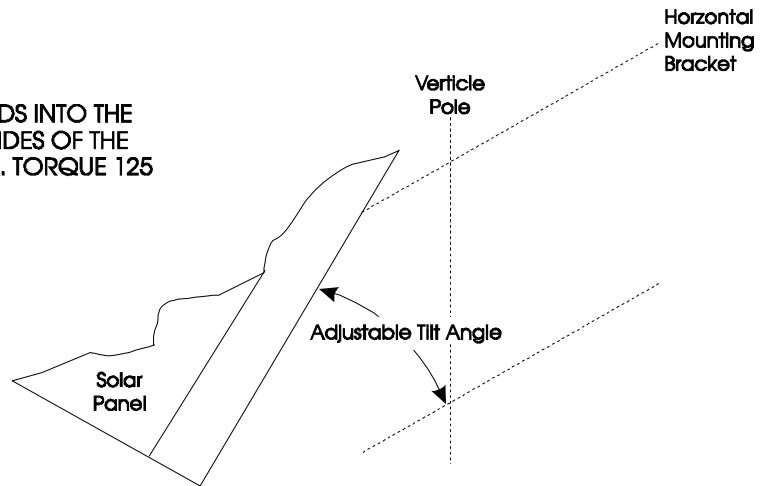

Figure 2-9. 5 Watt Solar Panel Mounting Diagram

2.3.6 Connections to RS-232 Serial Port(s) on the CPU/System Controller Board

An RS-232 port provides point-to-point, half-duplex and full-duplex communications (for a maximum of 20 feet using data quality cable).

Your CPU includes two RS-232 ports and one port configurable for either RS-232 or RS-485 operation.

RS-232 COM Port Names and Connectors

RS-232 COM ports use different connector types.

Table 2-6. RS-232 Connectors

Connector	Name	# Pins and Type	Notes
J4	COM1	9-pin male D-type	Choice of active connector for COM1 determined by jumper W18. J4 is factory wired to the local port connector on the outside bottom of the enclosure cover.
J11	COM1	3-pin male	Choice of active connector for COM1 determined by jumper W18.
TB3	COM2	8-pin terminal block	Supports the modem/radio option.
TB4	COM3	5-pin terminal block	This port can be configured as either RS-232 or RS-485. See Section 2.3.7 for more information.

RS-232 COM1/COM2 Port Cables

For the ControlWave ExpressPAC, half-duplex communications use Modbus or BSAP protocol, while full-duplex communications use point-to-point protocol (PPP). RS-232 ports use a “null modem” cable (see *Figure 2-11*) to connect with other devices (such as a PC, a printer, another ControlWave [except the CW_10/30/35]) when the ControlWave ExpressPAC uses the full-duplex PPP protocol.

Note: You can configure the ControlWave ExpressPAC as either a master or slave node on a Modbus or BSAP network.

Figure 2-10 illustrates the CPU module’s male 9-pin D-type connector for COM1. Use the content provided in *Table 2-7* to determine pin assignments for the COM1 and COM2 ports.

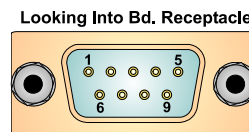

Figure 2-10. Male DB9 9-Pin Connector

Note: A factory-installed wiring harness connects J4 (COM1) to the circular 5-pin Local Port connector at the bottom of the enclosure cover.

Table 2-7. RS-232 COM1 (J4) and COM2 (TB3) Port Connector Pin Assignment

Pin	RS-232 Signal	RS-232 Description	Local Port (RS-232 Pin#)
1	DCD	Data Carrier Detect Input	1 (green wire)
2	RXD	Receive Data Input	2 (red wire)
3	TXD	Transmit Data Output	7 (white wire)
4	DTR	Data Terminal Ready Output	4 (brown wire – Pin 4 connected to pin 4 at TB5 of CPU = external power for local port communication cable)
5	GND	Power Ground	6 (black wire)
6	DSR	Data Set Ready Input	
7	RTS	Request to Send Output	RTS connected to CTS at J4 of CPU for local port communication cable
8	CTS	Clear to Send Input	RTS connected to CTS at J4 of CPU for local port communication cable
9		N/A	

Table 2-8. RS-232 COM1 (J11) Alternate Connector Pin Assignment

Pin	RS-232 Signal	RS-232 Description
1	GND	Power ground
2	RXD	Receive data input
3	TXD	Transmit data output

Use the “null modem” cable for full-duplex (PPP protocol) communications when connecting a ControlWave ExpressPAC to a PC. (See top part of *Figure 2-11*.)

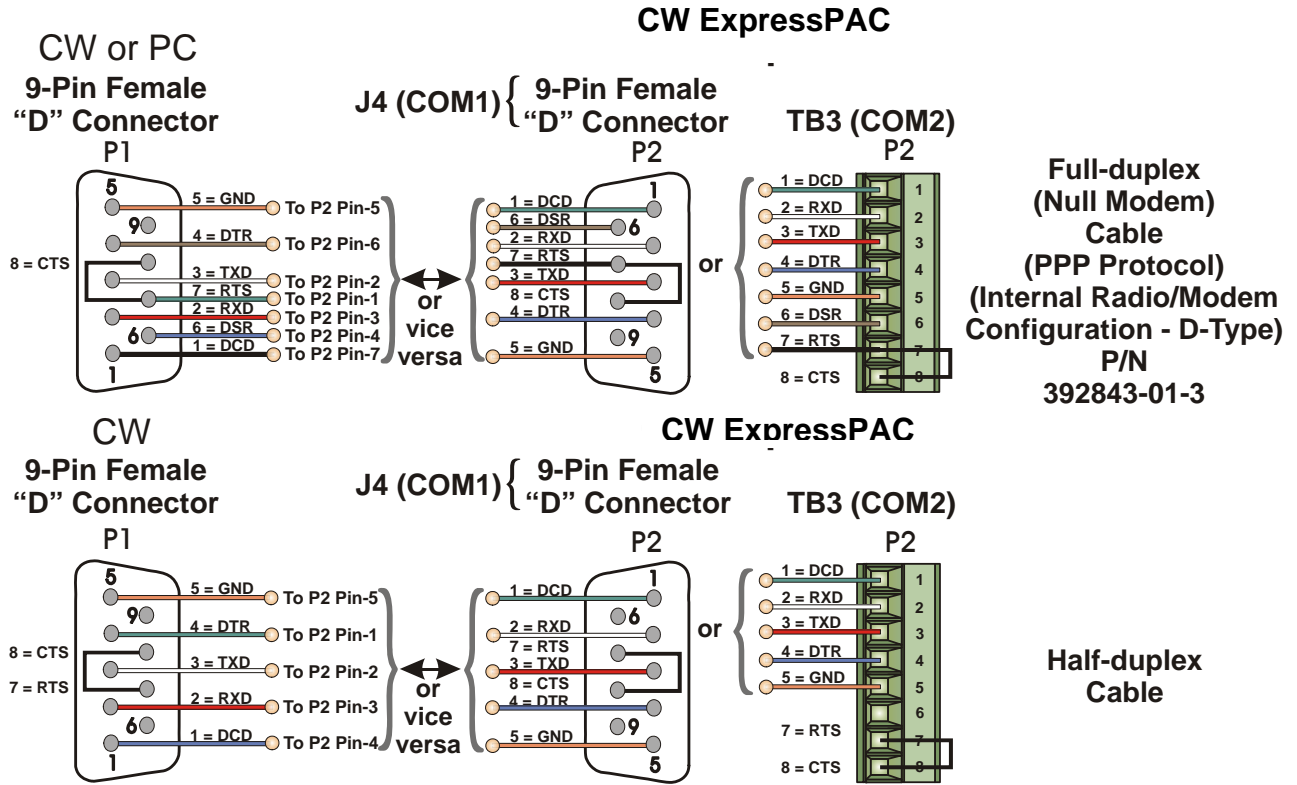

Figure 2-11. Full-duplex and Half-duplex Cable

Use the half-duplex cable (shown in the bottom part of *Figure 2-11*) when connecting the ControlWave ExpressPAC to another ControlWave series unit (again, with the exception of the CW_10/30/35).

When communicating with a Network 3000 series RTU 3305, RTU 3310, DPC 3330, or DPC 3335 or CW_10/30/35, you must use one of the cables shown in *Figure 2-12*.

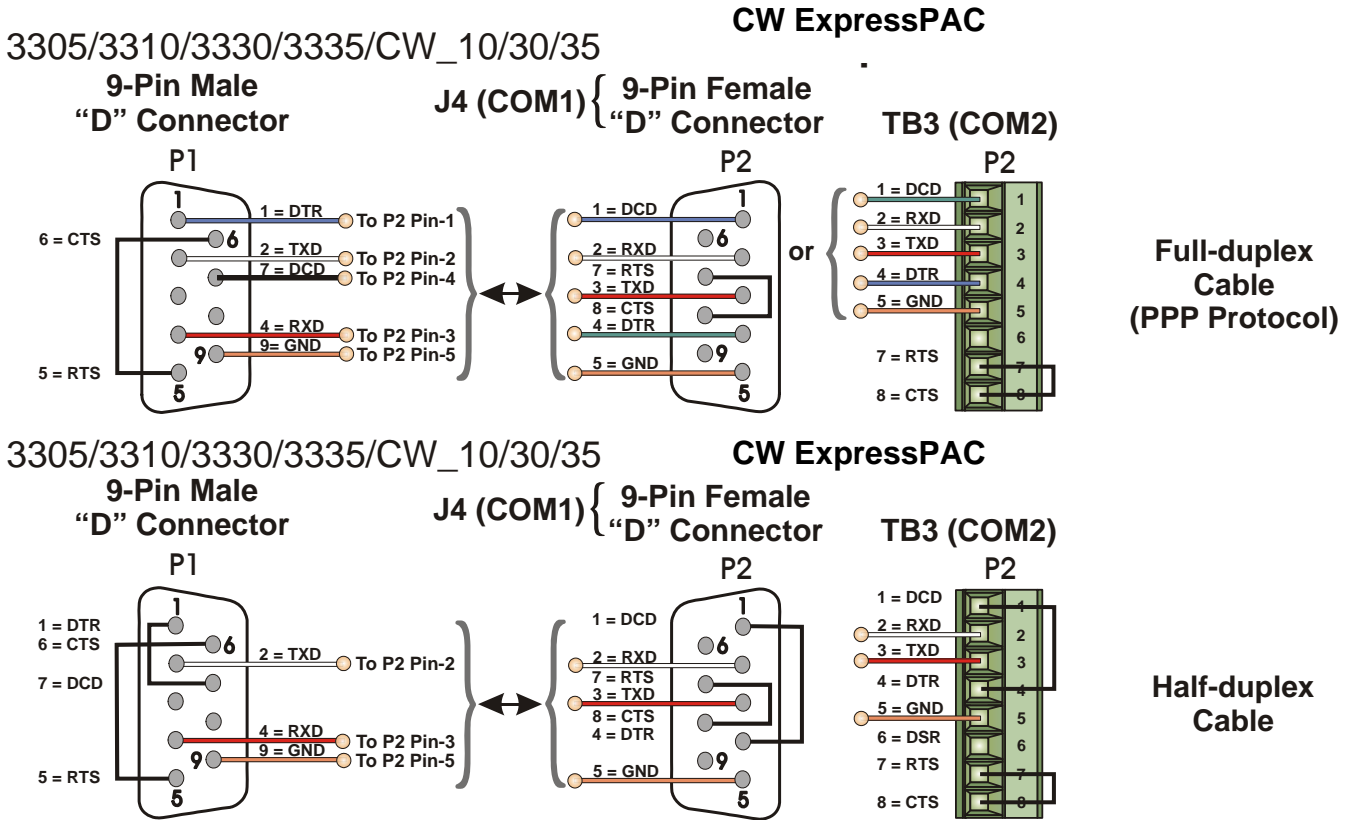

Figure 2-12. Full-duplex and Half-duplex Cable

Refer to Figure 2-13 when using COM2 of the ControlWave ExpressPAC to connect with a modem or radio (mounted on the battery cover/radio mounting bracket).

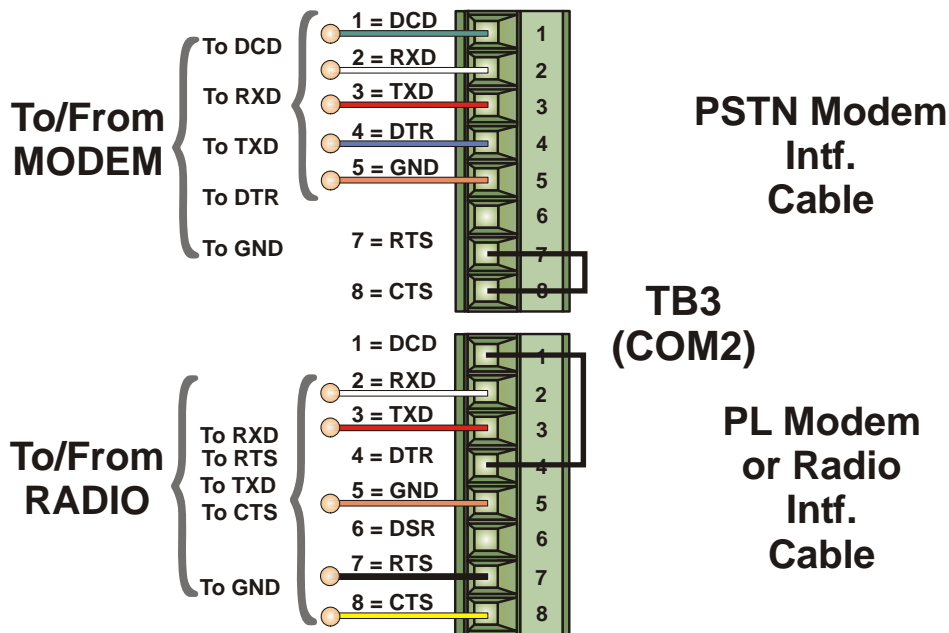

Figure 2-13. Connection from an Modem/Radio to COM2 of the ControlWave ExpressPAC

When interfacing to the COM3 port of a ControlWave, or the COM5 or COM6 port a ControlWaveEXP unit, use the cable presented in *Figure 2-14* along with one of the cables shown in *Figure 2-11* or *Figure 2-12*.

**RJ45 to DB9 Cable Ass’y.
(P/N 392844-01-0)**

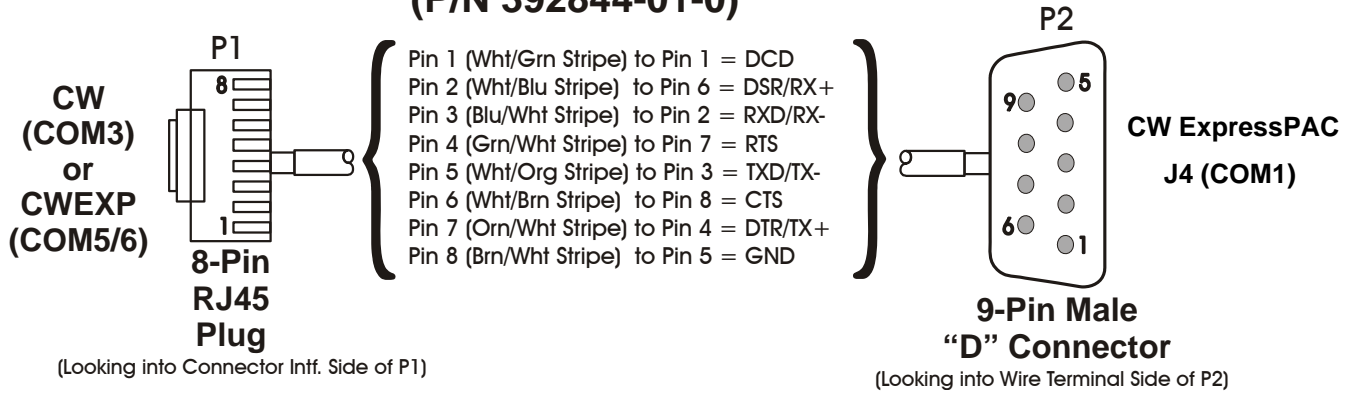

Figure 2-14. Full-duplex and Half-duplex Cable

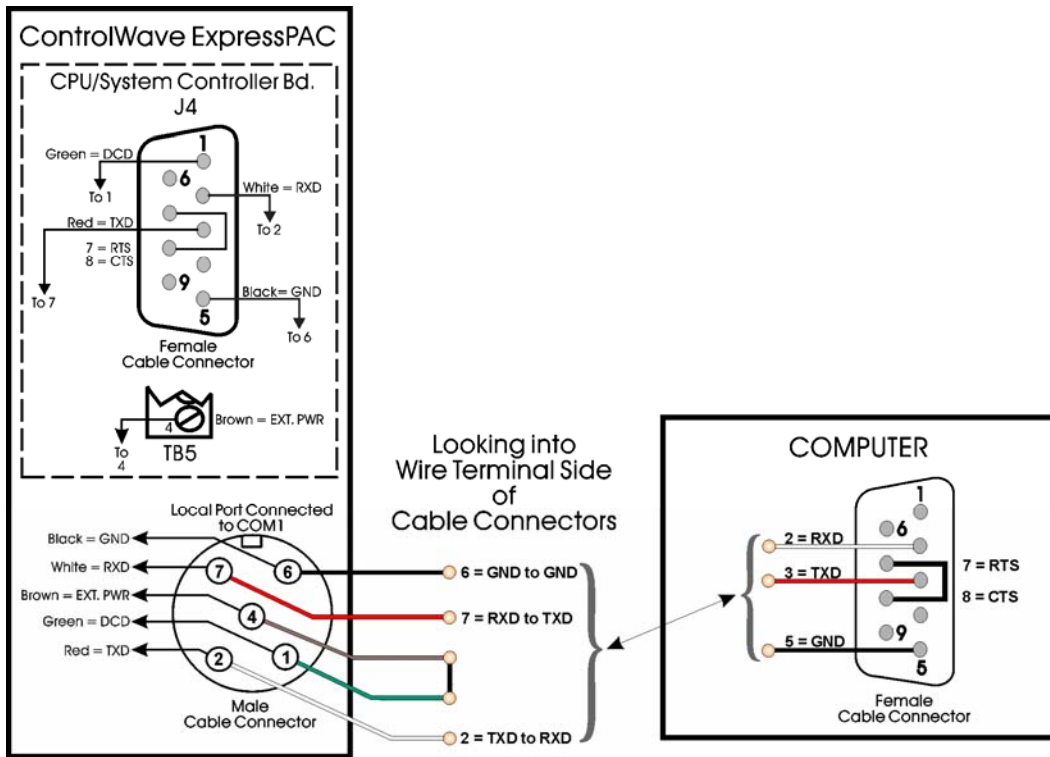

Figure 2-15. PC Connected to ControlWave ExpressPAC via Circular Local Port; 10-foot Cable Part Number 395402-01-8; 25-foot cable part number 395402-02-6

RS-232 Cable Guidelines

Observe the following guidelines when constructing RS-232 communication cables:

- Ensure that DCD is high to transmit (except when dialing a modem).
- Verify that each RS-232 transceiver has one active receiver while disabled (in power down mode); connect the DCD signal to the active receiver.
- Set CTS to high to transmit.
- If the port is set for full-duplex operation, RTS is always ON.
- Ensure that DTR is always high when port is active; DTR enables RS-232 transceivers.

Note: Control DTR using the PORTCONTROL function block and the `_Pn_AUTO_DTR` system variable in your ControlWave project. If you turn DTR off through these mechanisms, the port remains off, even though hardware is fully configured.

- When port is set for half-duplex operation, CTS must go low after RTS goes low.
- All RS-232 comm ports support RTS, DTR, CTS, DCD, and DSR control signals.
- All RS-232 comm port I/O signals are protected by surge protectors.

2.3.7 Connections to the COM3 (RS-485/RS-232) Serial Port on the CPU/System Controller Board

You use jumpers W12 through W16 to configure COM3 of the ControlWave ExpressPAC for either RS-232 or RS-485 operation. See *Section 2.3.2* for information on these jumpers.

Table 2-9. COM3 RS-485 Connector (TB4) on CPU/System Controller Board

Connector	Name	# Pins and Type	Notes
TB4	COM3	5-pin terminal block	This port can be configured as either RS-232 or RS-485.

RS-485 COM3 Port Cables

Table 2-10 shows connector pin assignments for COM3.

Note: If you use COM3 for RS-232 operation, pins 1 and 4 do not apply.

Table 2-10. COM3 Connector Pin Assignment

Pin	Signal	Description
1	RXD+	Receive Data + input (Not applicable for RS-232 usage)
2	RXD-/RXD	Receive Data – Input
3	TXD-/TXD	Transmit Data – Output
4	TXD+	Transmit Data + Output (Not applicable for RS-232 usage)
5	Power Ground	Ground

When serving as an RS-485 port, COM3 supports local network communications to multiple nodes up to 4000 feet away.

Since the RS-485 port is intended for network communications, refer to *Table 2-11* for the appropriate connections for wiring the master, first slave, and *n*th slave.

Essentially, the master and the first slave transmit and receive data on opposite lines; all slaves (from the first to the *n*th) are paralleled (daisy-chained) across the same lines. Wire the master node to one end of the RS-485 cable run using a 24-gauge paired conductor cable (such as a Belden 9843).

Note: ControlWave ExpressPAC supports **only** half-duplex RS-485 networks.

Table 2-11. RS-485 Network Connections

From Master	To First Slave	To nth Slave
TXD+	RXD+	RXD+
TXD-	RXD-	RXD-
RXD+	TXD+	TXD+
RXD-	TXD-	TXD-
GND	GND	GND

To ensure that the “Receive Data” lines are in a proper state during inactive transmission periods, you must maintain certain bias voltage levels at the master and most distant slave units (end nodes).

To establish proper network performance, you enable receiver biasing and termination (as well as 2-wire or 4-wire selection) using an 8-position DIP switch located on the CPU/System Controller board – see *Table 2-3*. The biasing and termination is required at the end nodes and is not used for other nodes of the network.

2.3.8 Connections to the Ethernet Port on the CPU/System Controller Board

Caution The RJ45 Ethernet port is connector (J1) located on the CPU/System Controller board. The board also has one RJ45 port (J2) for the optional Display/Keypad. **Never** connect Ethernet to J2 (the Display/Keypad port) or damage will result.

The 33MHz ControlWave ExpressPAC can support one Ethernet port. This port uses a 10/100Base-T RJ-45 modular connector (J1) that provides a shielded twisted pair interface to an Ethernet hub.

A typical Ethernet hub provides eight 10/100Base-T RJ-45 ports (with port 8 having the capability to link either to another hub or to an Ethernet communications port). Both ends of the Ethernet twisted pair cable are equipped with modular RJ-45 connectors.

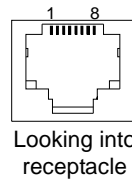

Figure 2-16. RJ-45 Ethernet Connector

These cables have a one-to-one wiring configuration as shown in Figure 2-17. Table 2-12 provides the assignment and definitions of the 8-pin 10/100Base-T connectors.

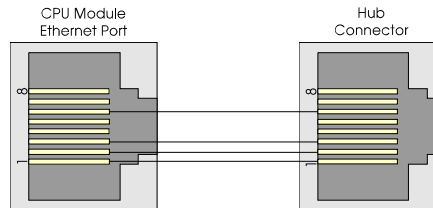

Figure 2-17. Standard 10/100Base-T Ethernet Cable (CPU Module to Hub)

Table 2-12. Ethernet 10/100Base-T CPU Module Pin Assignments

Pin	Description
1	Transmit Data+ (Output)
2	Transmit Data- (Output)
3	Receive Data+ (Input)
4	Not connected
5	Not connected
6	Receive Data- (Input)

Pin	Description
7	Not connected
8	Not connected

Note: You can swap TX and RX at the hub.

You can connect two nodes in a point-to-point configuration without using a hub. However, you must configure the cable so that the TX+/- Data pins connect to the RX+/- Data pins (swapped) at the opposite ends of the cable (see *Figure 2-18*).

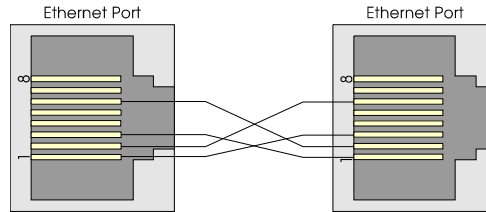

Figure 2-18. Point-to-Point 10/100Base T Ethernet Cable

The maximum length of one segment (CPU to hub) is 100 meters (328 feet). The use of Category 5 shielded cable is recommended.

2.4 Radios and Modems

ControlWave ExpressPAC supports several different third-party radios/modems. You can:

- order ControlWave ExpressPAC with the radio/modem factory installed within the enclosure (in front of the battery mounting bracket)
- order the unit without a radio/modem and then order the supported radio/modem from Emerson separately, and install it yourself. This option is called “radio-ready.” If you choose to install it yourself, you must ensure that the remote antenna (associated with a case-mounted radio) is properly installed and connected.

For information on configuring the third party radio/modem, see the documentation from the manufacturer.

For information on installing a radio in a radio-ready unit, see the *ControlWave Radio Ready Installation Guide (D5138)*.

2.5 Optional Display/Keypads

The ControlWave ExpressPAC supports two optional display/keypads and a display without a keypad:

- A 2-button keypad (shown in the left of *Figure 2-19*)
- A 25-button keypad (shown in the right *Figure 2-19*)

- Display only (no keypad) – (see *Figure 2-20*)

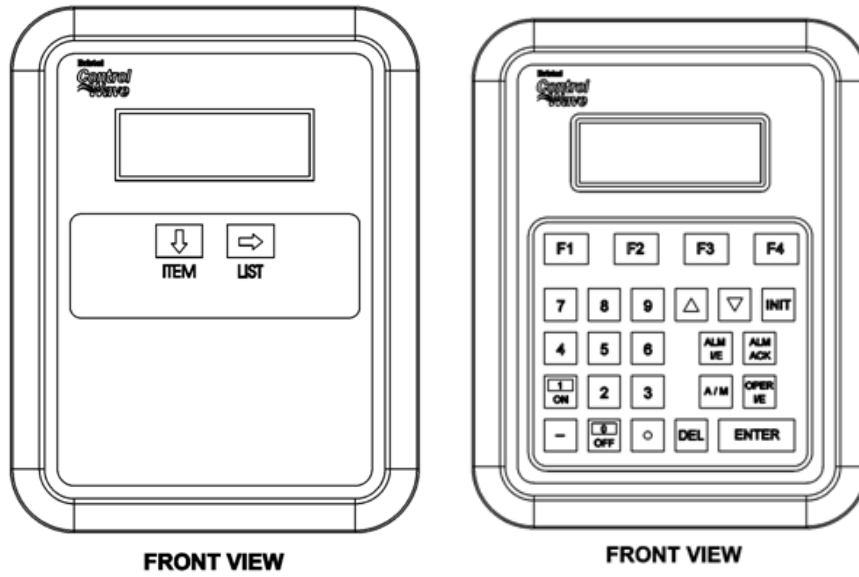

Figure 2-19. Optional 2-Button and 25-Button Keypads

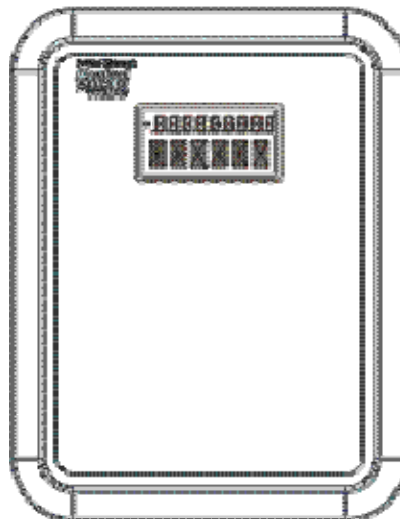

Figure 2-20. Display with No Keypad

Both keypads use the same 4-line by 20-character LCD displays.

The Display without a keypad has a 2-line display with 10 characters on the first line, and 6 characters on the second line. This display shows variable values on line 1, and variable names on line 2.

You connect the Display/Keypad or Display to the ControlWave ExpressPAC using a cable, one end of which has an RJ-45 jack (connected into the RJ-45 equipped with two plugs. This cable connects between the RJ-45 display jack (J2) on the CPU/System Controller board and RJ-45 jack (J1) on the remote Display or remote Display/Keypad assembly. A potentiometer, provided on the keypad, allows you to set the contrast of the LCD display.

Note: For further information on the installation and use of the optional keypads, refer to the *ControlWave Display/Keypad Manual (D5135)*.

This page is intentionally left blank

Chapter 3 – I/O Configuration and Wiring

This chapter discusses setting I/O configuration switches and jumpers and wiring I/O connections to the ControlWave ExpressPAC.

In This Chapter

3.1	I/O Options.....	3-1
3.2	Process I/O Board	3-2
3.2.1	Setting Jumpers on the Process I/O Board.....	3-2
3.2.2	Setting DIP Switches on the Process I/O Board	3-2
3.3	I/O Wiring.....	3-4
3.3.1	Non-Isolated Discrete Inputs (DI) on TB2 and TB3 of Process I/O Board.....	3-6
3.3.2	Non-Isolated Discrete Outputs (DO) on TB3 of Process I/O Board	3-7
3.3.3	Non-Isolated Analog Inputs (AI) on TB6 of Process I/O Board	3-8
3.3.4	Non-Isolated Analog Output (AO) on TB7 of Process I/O Board	3-9
3.3.5	Non-Isolated Pulse Counter/Discrete Inputs on TB5 of CPU/System Controller Board.....	3-10
3.3.6	Non-Isolated High Speed Counter (HSC) / Discrete Inputs (DI) on TB4 of Process I/O Board.....	3-11
3.3.7	Resistance Temperature Device (RTD) Inputs on CPU/System Controller Board	3-12
3.3.8	Connections to a Bristol Model 3808 Transmitter	3-14

3.1 I/O Options

ControlWave ExpressPAC comes with the following standard I/O:

- 2 Pulse Counter Inputs with a 1 second scan rate (can be configured as discrete inputs (DI))
- The 14 MHz CPU and the 33MHz CPU with Ethernet also includes a Resistance Temperature Device (RTD) probe.

In addition, three different versions of the optional process I/O board are available:

Table 3-1. Process I/O Configurations

Type	Discrete Input / Output (DI/DO)	Discrete Input (DI)	Discrete Output (DO)	High Speed Counter (HSC)	Analog Input (AI)	Analog Output (AO)
A	2	4	2	2		
B	2	4	2	2	3	
C	2	4	2	2	3	1

3.2 Process I/O Board

ControlWave ExpressPAC may include an optional Process I/O board.

The Process I/O board stands vertically on edge against the inner left side of the enclosure and mounts to the CPU/System Controller board using six nylon mounting posts.

To configure the Process I/O board, you need to set some switches and jumpers. See *Figure 3-1* for the location of the switches and jumpers.

3.2.1 Setting Jumpers on the Process I/O Board

The Process I/O board has several jumpers.

- **JP1:** AO output source (1-5V or 4-20mA):
 - 1-to-2 Installed = 4-20mA analog output
 - 2-to-3 Installed = 1-5V analog output
- **JP3:** AO power source:
 - 1-to-2 Installed = system power
 - 2-to-3 Installed = external power (+11 to +30 Vdc)
- **JP4:** AI field power configuration:
 - 1-to-2 Installed = external 24Vdc power
 - 2-to-3 Installed = bulk input supply (system power)
- **JP5:** AI1 input type (1-5V or 4-20mA)
 - 1-to-2 Installed = 4-20mA analog input
 - 2-to-3 Installed = 1-5V analog input
- **JP6:** AI2 input type (1-5V or 4-20mA)
 - 1-to-2 Installed = 4-20mA analog input
 - 2-to-3 Installed = 1-5V analog input
- **JP7:** AI3 input type (1-5V or 4-20mA)
 - 1-to-2 Installed = 4-20mA analog input
 - 2-to-3 Installed = 1-5V analog input

3.2.2 Setting DIP Switches on the Process I/O Board

The Process I/O board includes a single switch bank (SW1) to configure the frequency for the high speed counters (HSC), the source current for discrete inputs/counters, and the analog output.

Table 3-2. Process I/O Board Switch SW1

SW1	Function	Mode
SW1-1	Frequency for High Speed Counter1 (HSC1)	OFF = 10 kHz (high speed) ON = 300 Hz (low speed)
SW1-2	Frequency for High Speed Counter2 (HSC2)	OFF = 10 kHz (high speed) ON = 300 Hz (low speed)

SW1	Function	Mode
SW1-3	DI/HSC 2mA source current	OFF = disabled ON = enabled
SW1-4	AO configuration	OFF = current ON = voltage



Figure 3-1. Process I/O Board Component Identification Diagram



Caution

Power down the ControlWave ExpressPAC before you perform I/O wiring. Shut down any processes the ControlWave ExpressPAC may be managing (or switch them over manually or handle with another controller). Perform any hardware configuration (wiring, jumper configuration, and installation) only when the ControlWave ExpressPAC is powered down.

Before any I/O connections can become operational, you must use ControlWave Designer to configure and then download the application (project).

To ensure safe use of this product, please review and follow the instructions in the following supplemental documentation:

- Supplement Guide - ControlWave Site Considerations for Equipment Installation, Grounding, and Wiring (S1400CW)
- ESDS Manual – Care and Handling of PC Boards and ESD Sensitive Components (S14006)

3.3 I/O Wiring

The ControlWave ExpressPAC uses card edge terminal blocks to accommodate field wiring. You route the wires into the enclosure/chassis through the left side of the unit (right when facing the front) via a 3/4 inch conduit fitting.

ControlWave ExpressPAC I/O uses compression-type terminals that accommodate up to #16 AWG wire. Insert the wire's bared end (approx. 1/4" max) into the clamp beneath the screw and secure the wire. To prevent shorts, ensure that no bare wire is exposed. If using standard wire, tin the bare end with solder to prevent flattening and improve conductivity. Allow some slack in the wires when making terminal connections. Slack makes the wires more manageable and helps minimize mechanical strain on the terminal blocks.

Shielding and Grounding

Use twisted-pair, shielded and insulated cable for I/O signal wiring to minimize signal errors caused by electromagnetic interference (EMI), radio frequency interference (RFI), and transients. When using shielded cable, ground all shields at only one point in the appropriate system. This prevents circulating ground current loops that can cause signal errors.

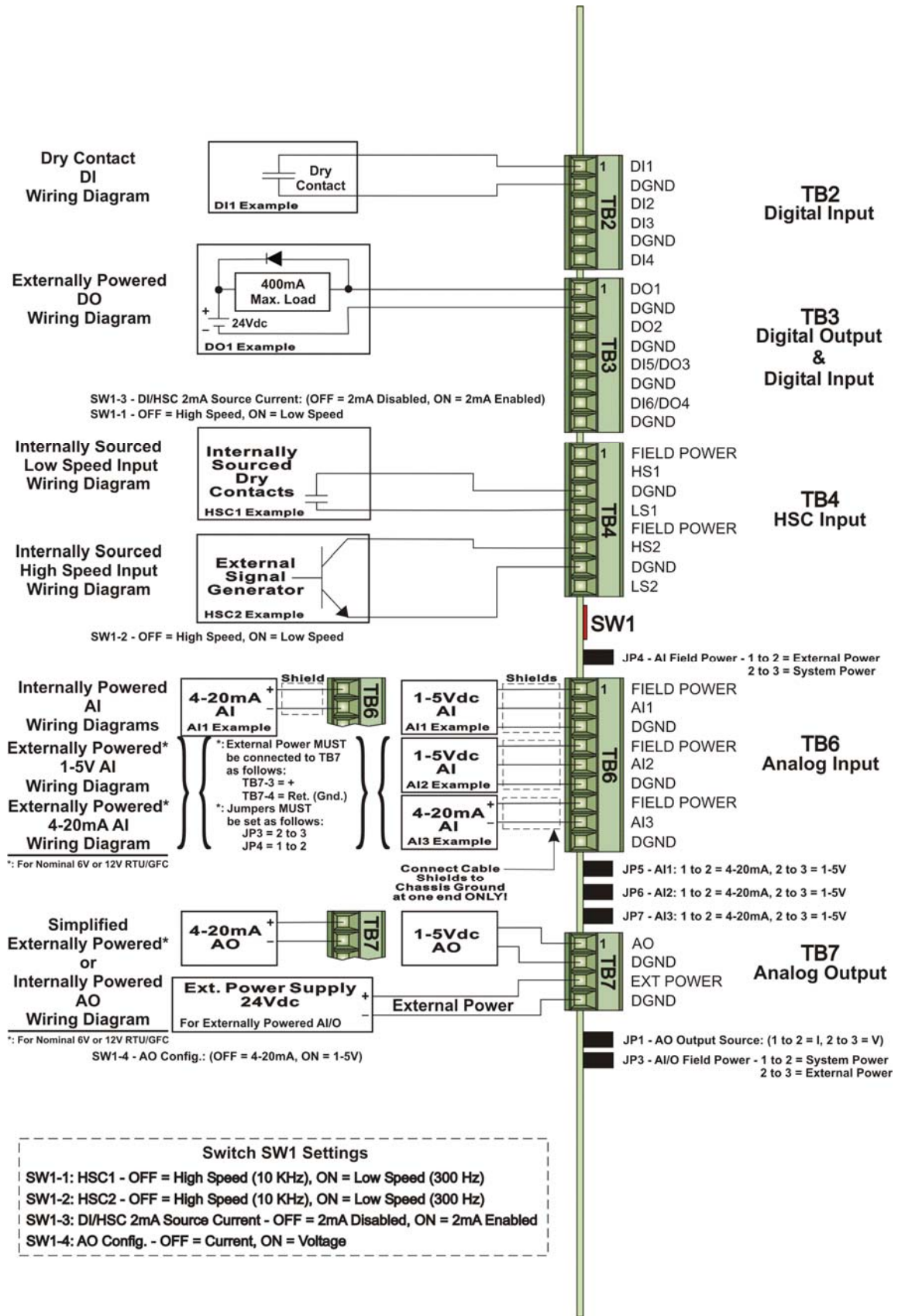

Figure 3-2. Process I/O Board Wiring Diagrams

3.3.1 Non-Isolated Discrete Inputs (DI) on TB2 and TB3 of Process I/O Board

Process I/O Board terminal block connector TB2 provides interface to four dedicated internally-sourced, non-isolated Discrete Inputs DIs – DI1 through DI4. In addition, terminal block connector TB3 provides two additional points that can serve as either discrete inputs or discrete outputs (DI5 and DI6 when wired as inputs).

Table 3-3. Non-Isolated DI General Characteristics

Type	Number Supported	Characteristics
Discrete Inputs (DI)	4 on TB2 (optionally 2 on TB3)	<ul style="list-style-type: none"> ▪ Supports dry contact inputs pulled internally to 3.3 Vdc when field input is open. ▪ Source current for DI1 to DI4 of either 60 μA or 2 mA based on switch SW1-3 setting. See <i>Table 3-2</i>. ▪ Source current for DI5 to DI6 of either 200 μA or 2.2 mA based on switch SW1-3 setting. See <i>Table 3-2</i>. ▪ 15 ms input filtering

Wiring See *Figure 3-2* for wiring diagrams.

Software Configuration To use data from these DIs you must include a **CWM_EIO** board in your ControlWave project using ControlWave Designer's I/O Configurator, and then configure it. See the *ControlWave Designer Programmer's Handbook* (D5125) for more information. That same manual includes an *I/O Mapping* section that describes, for advanced users, the I/O map for this board.

Note: You must specify whether a discrete input/output is a DI or a DO in ControlWave Designer's I/O Configurator by configuring a DI pin or a DO pin.

3.3.2 Non-Isolated Discrete Outputs (DO) on TB3 of Process I/O Board

Process I/O Board terminal block connector TB3 provides interface to two dedicated non-isolated discrete outputs DOs – DO1 and DO2. In addition, terminal block connector TB3 provides two additional points that can serve as either discrete inputs or discrete outputs (DO3 and DO4 when wired as outputs).

Table 3-4. Non-Isolated DO General Characteristics

Type	Number Supported	Characteristics
Discrete Outputs (DO)	2 to 4 (on TB3)	<ul style="list-style-type: none"> ▪ Supports 30V operating range. Can sink 400 mA max at 30Vdc (open drain). ▪ Maximum output frequency of 20Hz. ▪ Surge protection between signal and ground.

Wiring See *Figure 3-2* for wiring diagrams.

Software Configuration To use data from these DOs you must include a **CWM_EIO** board in your ControlWave project using ControlWave Designer's I/O Configurator, and then configure it. See the *ControlWave Designer Programmer's Handbook* (D5125) for more information. That same manual includes an *I/O Mapping* section that describes, for advanced users, the I/O map for this board.

Note: You must specify whether a discrete input/output is a DO or a DI in ControlWave Designer's I/O Configurator by configuring a DO pin or a DI pin.

3.3.3 Non-Isolated Analog Inputs (AI) on TB6 of Process I/O Board

Process I/O Board terminal block connector TB6 provides interface to three single-ended analog inputs (AIs).

Table 3-5. Non-Isolated AI General Characteristics

Type	Number Supported	Characteristics
Analog Inputs (AI)	3 (on TB6)	<ul style="list-style-type: none"> ▪ Jumper-selectable using JP5, JP6, and JP7 for either 4-20mA or 1-5V operation. ▪ Jumper JP4 determines whether AI field power comes from system power (bulk input supply applied to TB1-3 and TB1-4 on the CPU/System Controller board) or the external loop power source connected to TB7-3 and TB7-4 on the Process I/O board. ▪ 2 Hz low pass filter for each AI. ▪ Surge Suppression. ▪ Self calibrating.

Setting Jumpers See *Section 3.2.1* for details on setting jumpers.

Wiring Each AI includes three terminals (field power, AI# and DGND). See *Figure 3-2* for wiring diagrams. If using the ControlWave Loop Power Supply, see document *PIP-ControlWave-LS*.

Notes:

- You must connect cable shields associated with AI wiring to the ControlWave ExpressPAC chassis ground.
- Multiple shield terminations require you to supply a copper ground bus. You must connect the ground bus to the ControlWave ExpressPAC chassis ground using up to a #4 AWG wire size. The ground bus must accommodate a connection to a known good Earth ground (in lieu of a direct connection from the ControlWave ExpressPAC chassis ground) and to all AI cable shields.
- Use an appropriate terminal lug for shield wires and secure them to the copper bus using industry rugged hardware (screw/bolt, lock washer and nuts).

Software Configuration To use data from these AIs you must include a **CWM_EIO** board in your ControlWave project using ControlWave Designer's I/O Configurator, and then configure it. See the *ControlWave Designer Programmer's Handbook* (D5125) for more information. That same manual includes an *I/O Mapping* section that describes, for advanced users, the I/O map for this board.

3.3.4 Non-Isolated Analog Output (AO) on TB7 of Process I/O Board

Process I/O board terminal block connector TB7 provides interface to a single analog output (AO).

Table 3-6. Non-Isolated AO General Characteristics

Type	Number Supported	Characteristics
Analog Output (AO)	1 (on TB7)	<ul style="list-style-type: none"> ▪ Supports either 4-20mA or 1-5V operation. Selection using jumper JP1 and switch SW1-4. ▪ Jumper JP3 determines whether AO field power comes from system power (nominally 12 or 24V from bulk input supply applied to TB1-3 and TB1-4 on the CPU/System Controller board) or from an external 24V power source (+11 to +30Vdc connected to TB7-3 and TB7-4) such as the ControlWave Loop Power Supply. ▪ Maximum external load you can connect to a 4-20mA output is 250 ohms for an external 11V power source or 650 ohms for an external 24V power source. ▪ Maximum external load current for the 1-5V output is 5 mA (with an external 11 to 30 V power source.) ▪ Self calibrating.

Setting Jumpers See *Section 3.2.1* for details on setting jumpers.

Wiring See *Figure 3-2* for wiring diagrams. If using the ControlWave Loop Power Supply, see document *PIP-ControlWave-LS*.

Note: **If your ControlWave ExpressPAC uses 6V bulk power, you must provide external power for the AO.**

Software Configuration To use data from this AO you must include a **CWM_EIO** board in your ControlWave project using ControlWave Designer's I/O Configurator, and then configure it. See the *ControlWave Designer Programmer's Handbook (D5125)* for more information. That same manual includes an *I/O Mapping* section that describes, for advanced users, the I/O map for this board.

3.3.5 Non-Isolated Pulse Counter/Discrete Inputs on TB5 of CPU/System Controller Board

CPU/System Controller board connector TB5 provides interface to two internally sourced open collector pulse counter/discrete inputs (Pulse1 and Pulse2) with a 1 second scan rate. Pulse counters act like high speed counters but cannot function with contact relays because they lack contact debounce circuitry.

Table 3-7. Non-Isolated Pulse Counter/Discrete Inputs General Characteristics

Type	Number Supported	Characteristics
Pulse Counter / Discrete Inputs	2 on TB5 of CPU/System Controller board	<ul style="list-style-type: none"> ▪ Signal conditioning circuitry provides 20 microsecond filtering. ▪ Surge suppression. ▪ Maximum input frequency for each pulse counter/discrete input circuit is 10 KHz.

Wiring Pulse counter/discrete inputs are field driven by open collector circuits and are sourced for 3.3V (internally) with a 200 μ A source current. See Figure 3-3 for information on the open collector wiring arrangement.

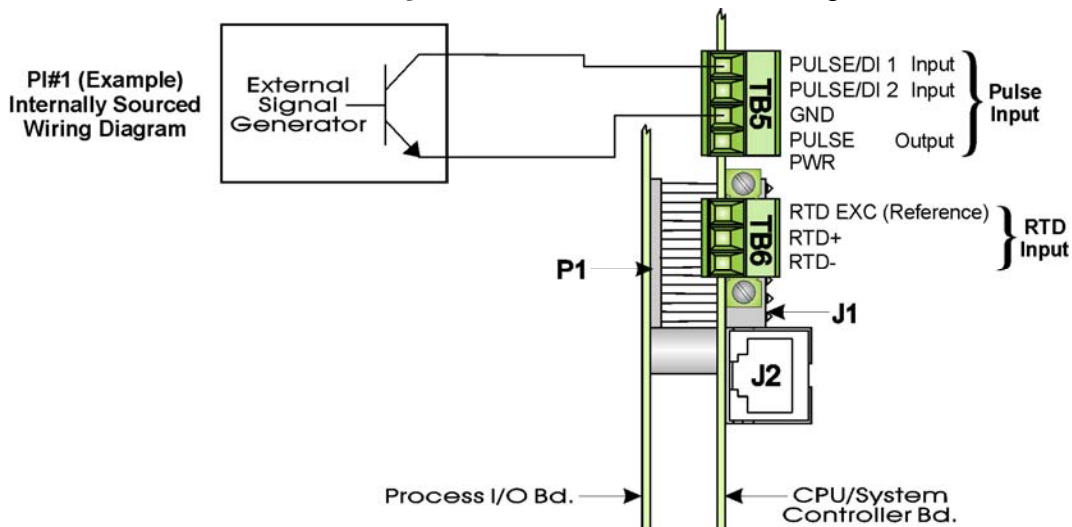

Figure 3-3. Pulse Input Wiring Diagram

Software Configuration To use data from these pulse counter/discrete inputs you must include a `CWM_ECPU` board in your ControlWave project using ControlWave Designer's I/O Configurator, and then configure it. See the *ControlWave Designer Programmer's Handbook* (D5125) for more information. That same manual includes an *I/O Mapping* section that describes, for advanced users, the I/O map for this board. To read a DI value, look at the appropriate offset for the `_STATE` variable for the board.

3.3.6 Non-Isolated High Speed Counter (HSC) / Discrete Inputs (DI) on TB4 of Process I/O Board

Process I/O board connector TB4 provides interface to two internally sourced single-ended high speed counter/discrete inputs (HSC1 and HSC2).

Table 3-8. Non-Isolated High Speed Counter/Discrete Inputs General Characteristics

Type	Number Supported	Characteristics
High Speed Counter / Discrete Inputs	2 on TB4 of Process I/O board	<ul style="list-style-type: none"> ▪ Surge suppression and signal conditioning. ▪ HSCs can use dry contacts or open collector field circuits. ▪ High speed counter switch-selectable frequency of 10kHz or 300Hz. ▪ Sourced from 3.3Vdc and switch selectable for a source current of 200µA (switch SW1-3 = OFF) or 2.2mA (switch SW1-3 = ON). Note: These switches affect all DIs and HSCs.

Wiring See *Figure 3-2* for wiring diagrams.

Switch Settings See *Table 3-2* for details on setting switches.

Software Configuration To use data from these high speed counter/discrete inputs you must include a **CWM_EIO** board in your ControlWave project using ControlWave Designer's I/O Configurator, and then configure it. See the *ControlWave Designer Programmer's Handbook (D5125)* for more information. That same manual includes an *I/O Mapping* section that describes, for advanced users, the I/O map for this board. To read a DI value, look at the appropriate offset for the `_STATE` variable for the board.

3.3.7 Resistance Temperature Device (RTD) Inputs on CPU/System Controller Board

CPU/System Controller board connector TB6 provides connection to a 3-wire 100 ohm platinum bulb RTD (using the DIN 43760 curve). The RTD connection enters the unit through the bottom of the enclosure.

Wire the RTD according to *Table 3-9* and *Figure 3-4* and *Figure 3-5*. In this configuration, the return lead connects to the RTD- terminal and the two junction leads (Sense and Excitation) connect to the RTD+ and RTD EXC terminals.

Caution

Never ground the RTD cable shield at both ends or allow it to come in contact with metallic/conductive conduit because multiple ground paths can cause RTD input errors.

Table 3-9. RTD Connections to CPU/System Controller Board Connector TB6

TB6 Pin	Signal	Function
1	RTD EXC	Reference
2	RTD+	Sense
3	RTD-	Return

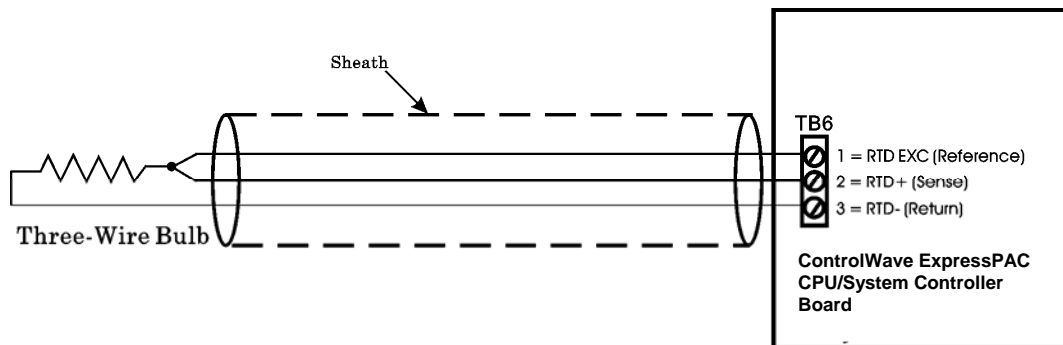

Figure 3-4. 3-Wire RTD Temperature Input Wiring

Installing the RTD Probe

To install the RTD probe, screw the fitting body into the thermowell with a 7/8" open-end wrench. While you apply pressure against the sheath to force the tip of the RTD probe into the bottom of the thermowell (so that the probe tip is in contact with the bottom of the thermowell), tighten the 9/16" nut using an open-end wrench against the 7/8" fitting body.

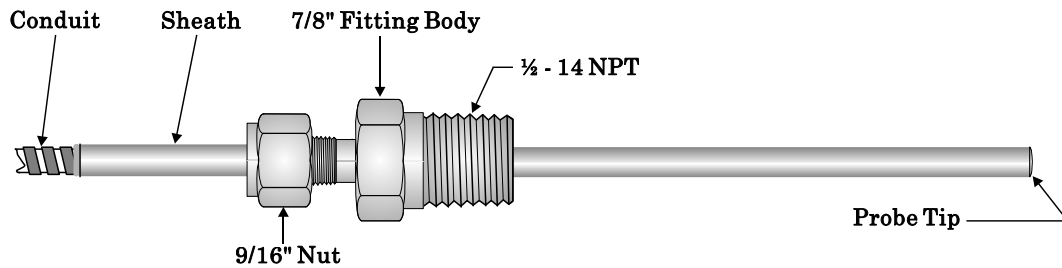

Figure 3-5. RTD Probe Installation/Removal Diagram

Software Configuration

To use data from the RTD you must include a **CWM_ECPU** board in your ControlWave project using ControlWave Designer's I/O Configurator, and then configure it. See the *ControlWave Designer Programmer's Handbook* (D5125) for more information. That same manual includes an *I/O Mapping* section that describes, for advanced users, the I/O map for this board.

3.3.8 Connections to a Bristol Model 3808 Transmitter

You can connect a Bristol 3808 transmitter (digital) to the ControlWave ExpressPAC through either an RS-232 or RS-485 port. Communication schemes and cable lengths determine the type of communication port you need to use. In general RS-232 communications require that you place the 3808 transmitter within 25 feet of the ControlWave ExpressPAC (local communications). You can use RS-485 communications to reach transmitters up to 4000 feet away (remote communications).

Figure 3-6 details RS-232 wiring connections required between the ControlWave ExpressPAC and the 3808 transmitter.

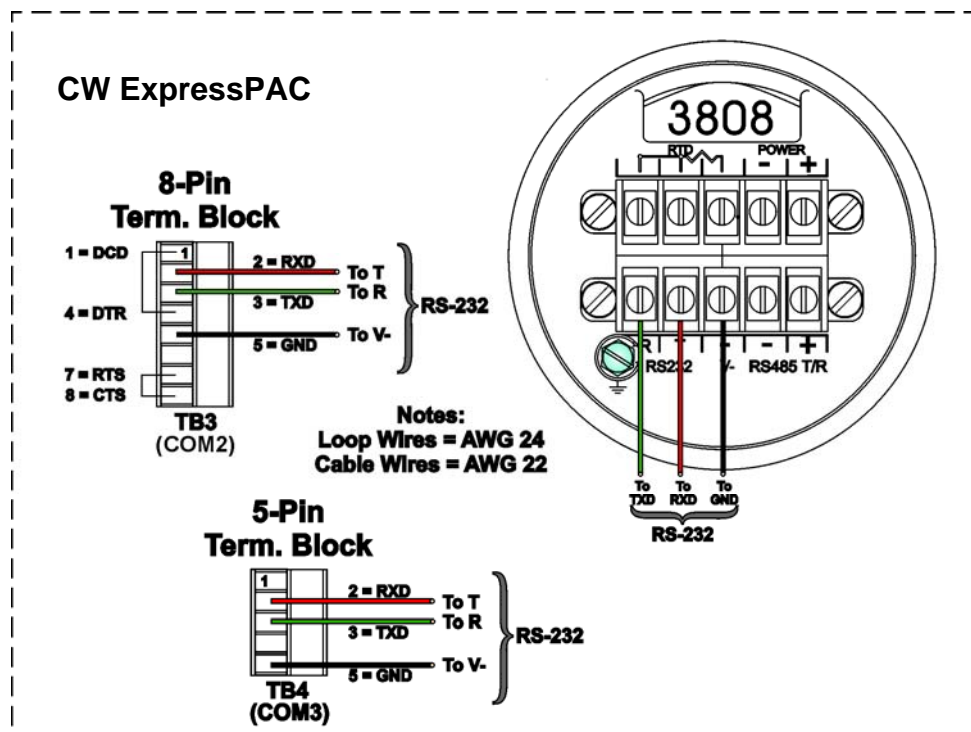

Figure 3-6. 3808 Transmitter to ControlWave ExpressPAC RS-232 Comm. Cable Diagram

Figure 3-7 details RS-485 wiring connections required between the ControlWave ExpressPAC and the 3808 transmitter.

Note: For loopback and termination control, use switch SW3 on the CPU/System Controller board to configure COM3.

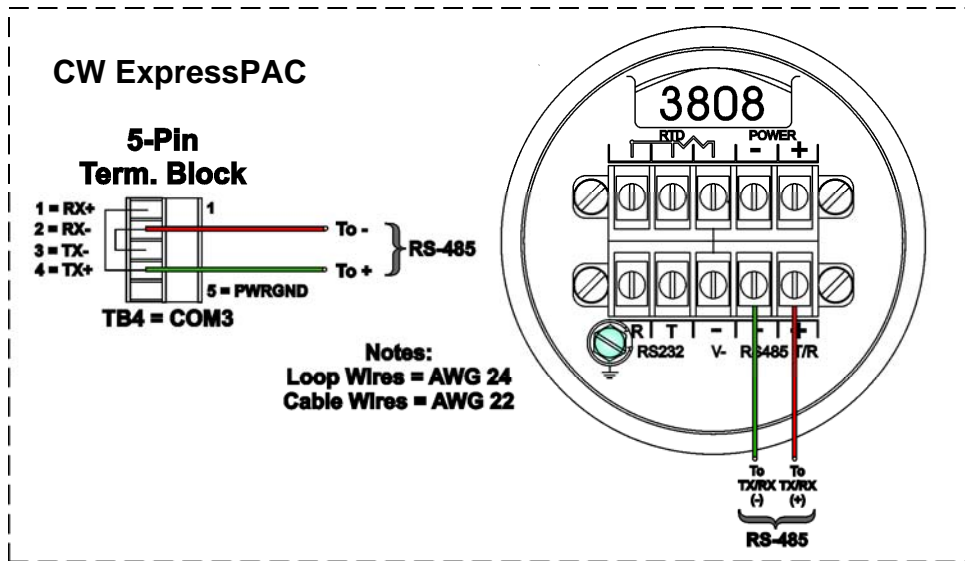

Figure 3-7. 3808 Transmitter to ControlWave ExpressPAC RS-485 Comm. Cable

You can connect up to two 3808 transmitters to a ControlWave ExpressPAC using a half-duplex RS-485 network. See Figure 3-8 for an illustration of this type of network.

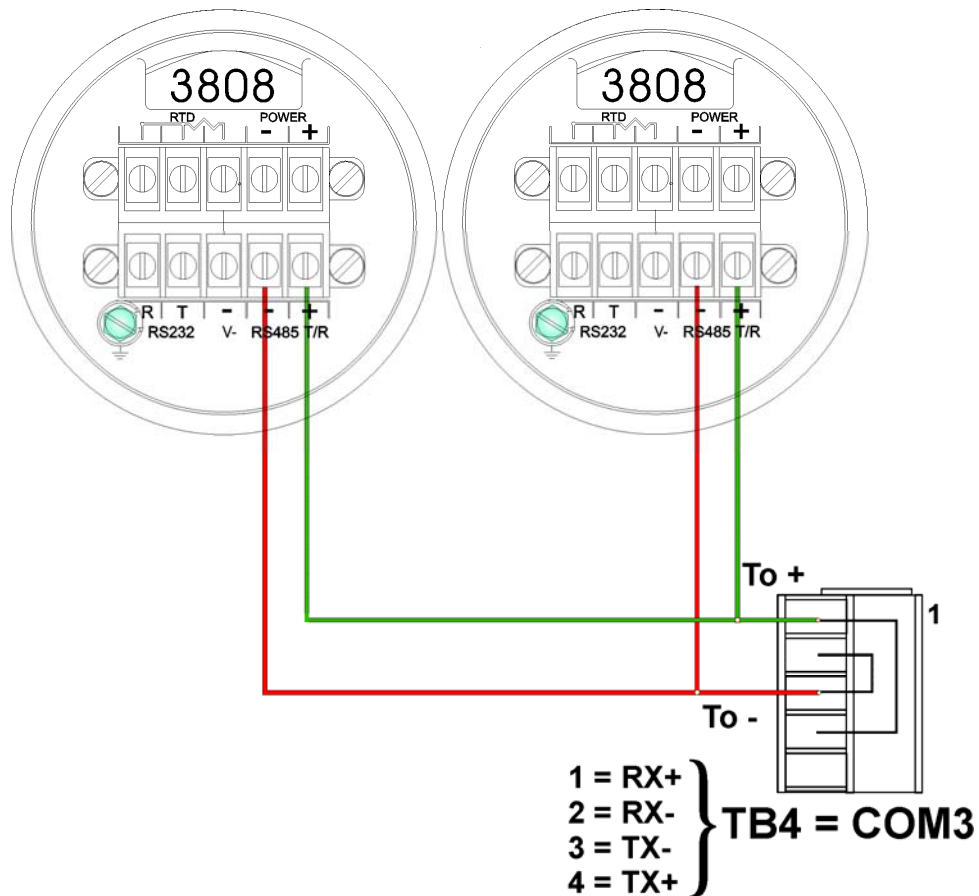

Figure 3-8. ControlWave ExpressPAC to 3808s - RS-485 Network Diagram

This page is intentionally left blank

Chapter 4 – Operation

This chapter provides general operational details for using the ControlWave ExpressPAC.

In This Chapter

4.1	Powering Up/Powering Down the ControlWave ExpressPAC	4-1
4.2	Communicating with the ControlWave ExpressPAC	4-2
4.2.1	Default Comm Port Settings.....	4-2
4.2.2	Collecting Data from the ControlWave ExpressPAC	4-2
4.3	Creating and Downloading an Application (ControlWave Project) ..	4-3
4.4	Creating and Maintaining Backups.....	4-3
4.4.1	Creating a Zipped Project File (*.ZWT) For Backup	4-4
4.4.2	Saving Flash Configuration Parameters (*.FCP)	4-5
4.4.3	Backing up Data.....	4-6

WARNING EXPLOSION HAZARD

Substitution of components may impair suitability for use in Class I, Division 2 environments.

When the ControlWave ExpressPAC is situated in a hazardous location, turn off power before servicing or replacing the unit and before installing or removing I/O wiring.

Do not disconnect equipment unless the power is switched off or the area is known to be non-hazardous.

4.1 Powering Up/Powering Down the ControlWave ExpressPAC

The ControlWave ExpressPAC receives power either from a solar panel and factory-supplied battery or from an external bulk power supply attached using connector TB1 on the CPU/System Controller board. It can also receive power through alternate connector TB2 on the same board. *Chapter 2* includes instructions for wiring power to the ControlWave ExpressPAC. See *Figure 2-3* for the location of these connectors.

Power Up To apply power to the ControlWave ExpressPAC, plug in connectors TB1 and optionally TB2 on the CPU/System Controller board. If your ControlWave project resides in flash memory, the project will load into SRAM and begin execution. Depending upon the setting of the SRAM control switch, retain variable values may load as well.

 **Caution** When you disconnect power from the ControlWave ExpressPAC, your running control strategy is erased from SRAM, as is any process data not stored in retention mode. When configured for retention and the backup battery remains good, SRAM stores the last states of all I/O points, audit/archive data not residing in FLASH, the values of all variables marked RETAIN, the values of variables stored in the static memory area, and any pending unreported alarm messages.

Power Down To remove power from the ControlWave ExpressPAC, unplug connectors TB1 and TB2 from the CPU/System Controller board.

4.2 Communicating with the ControlWave ExpressPAC

You communicate to the ControlWave ExpressPAC by connecting a cable between a port on your PC workstation and one of the ControlWave ExpressPAC ports.

The port at the PC workstation must match the configuration of the ControlWave ExpressPAC port.

4.2.1 Default Comm Port Settings

As delivered from the factory, ControlWave ExpressPAC communication ports have default settings. *Table 4-1* details these defaults.

Table 4-1. Default Comm Port Settings (by PCB)

Port	PCB	Default Configuration
COM1	CPU	RS-232; 115.2 Kbps using BSAP or ControlWave Designer protocol.
COM2	CPU	RS-232; 9600 baud, 8 bits, no parity, 1 stop bit, BSAP or ControlWave Designer protocol
COM3	CPU	RS-485; 9600 baud, 8 bits, no parity, 1 stop bit, BSAP or ControlWave Designer protocol. Intended for use with Bristol 3808 transmitters. You use jumpers W12 through W16 to configure COM3 for either RS-232 or RS-485

Note: You can re-enable the factory comm settings at any time by setting switch 3 on the CPU module's SW3 to "OFF."

Ethernet Using an optional Ethernet port (located on the CPU module), you can connect either directly or through a network to a PC equipped with an Ethernet port. The default IP address and mask for the Ethernet port is:

- ETH1 IP Address: 10.0.1.1 IP Mask: 255.255.255.

4.2.2 Collecting Data from the ControlWave ExpressPAC

OpenBSI utilities such as DataView, Data Array Save/Restore and Harvester allow you to collect real time data (values of variables, array values, alarm messages) and historical data (audit records, archive files) from the ControlWave. See the *OpenBSI Utilities Manual (D5081)* for details. SCADA software such as OpenEnterprise can then present this data to an operator in the form of graphical displays and reports.

4.3 Creating and Downloading an Application (ControlWave Project)

Your ControlWave ExpressPAC executes an application called a ControlWave project. You create the project using PC-based ControlWave Designer software. Instructions for creating a ControlWave project are beyond the scope of this manual. Please refer to the following sources for information:

- *Getting Started with ControlWave Designer* (D5085)
- *ControlWave Designer Programmer's Handbook* (D5125)
- ControlWave Designer online help

You must connect the ExpressPAC to a PC running ControlWave Designer software and OpenBSI software.

Note: You can download an application either from ControlWave Designer or from the OpenBSI 1131 Downloader.

1. Connect a serial cable between your PC and COM2 of the ControlWave ExpressPAC.
2. Define the ControlWave project in ControlWave Designer, and set communication and configuration parameters.
3. Download the project according to instructions in the *Downloading* section of the *ControlWave Designer Programmer's Manual* (D5125).

4.4 Creating and Maintaining Backups

You should always maintain a current backup of each ControlWave project and keep it in a safe place, preferably in a location physically separate from the controller.

The reason we recommend you keep backup files is that if a disaster occurs that damages or destroys your ControlWave hardware (flood, lightning strike, etc.) you don't want to also lose its control strategy software programs. Otherwise, when the unit is repaired or replaced, you'd have to create a new ControlWave project from scratch, which might take a lot longer than replacing a few damaged modules.

**Caution**

Always maintain a backup copy of your ControlWave project in a safe place.

Anytime you modify your ControlWave project, be sure to create a new backup of the new project.

Notes:

- You may find it useful to maintain more than one backup copy in case the backup media itself fails, for example, a CD-ROM becomes unreadable because it melted in the sun or a thumb drive fails because someone spilled coffee on it.
- If you don't keep more than one backup copy, it's a good idea to periodically test your backup copy to verify that the media has not failed.

4.4.1 Creating a Zipped Project File (*.ZWT) For Backup

Note: The .zwt file is a complete backup of your entire project including code, comments and graphics. It may be stored on your PC or removable storage media. It may also be downloaded and archived to ControlWave Flash memory where it may be uploaded at a later time for editing.

With your current ControlWave project open in ControlWave Designer, perform the following steps:

1. Click **File > Save Project As / Zip Project As**.

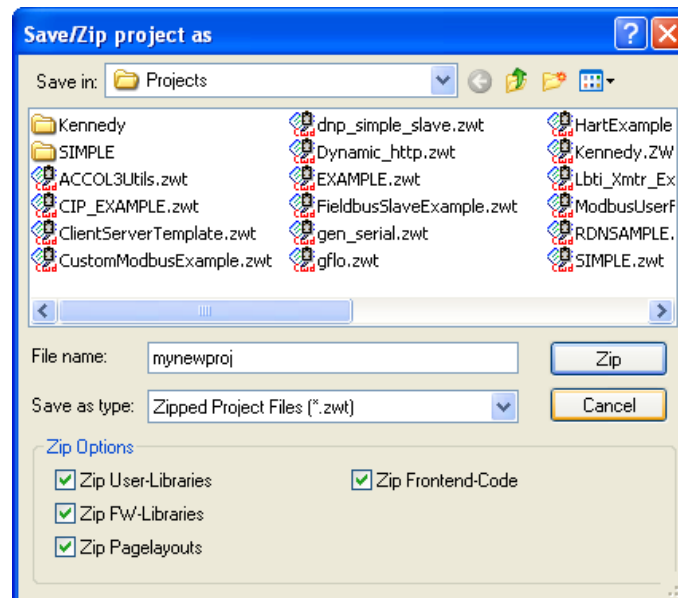

Figure 4-1. Saving a Backup of Your Project

2. In the “Save/Zip project as” dialog box, specify a project name in the **File name** field. In *Figure 4-1* we chose the name **mynewproj**.
3. In the **Save as type** field, choose **Zipped Project Files (*.zwt)**.
4. In the **Zip Options** area, select which additional files you want to include in the zwt file. Other than increasing the file size of the zwt, it doesn't hurt to check any or all of these options.

Zip Option	Description
Zip User-Libraries	If you created your own user-defined functions or function blocks, you must select this to preserve them.
Zip Frontend-Code	If you selected Zip User-Libraries you should also select this option to include compiled code for libraries in your zip file. Otherwise, you need to re-compile your user libraries with the project when you unzip the zwt.
Zip FW-Libraries	This includes firmware libraries, such as ACCOL3.FWL in your zwt.
Zip Pagelayouts	This includes pagelayout information for printing your project, as well as graphical elements used in certain 1131 languages.

- Click **Zip** and a progress bar displays the percent complete of the zipping process.
- When the zip process completes, you'll see a message box reporting successful completion. Click **OK**.
- Copy the resulting zwt file to backup media (CD-ROM, thumb drive, etc.) If you ever need to restore the project, just open the zwt file in ControlWave Designer, load libraries as needed, then compile the project and download it into the ControlWave.

4.4.2 Saving Flash Configuration Parameters (*.FCP)

You must establish communications with the ControlWave ExpressPAC using NetView, LocalView, or TechView before you can run the Flash Configuration utility.

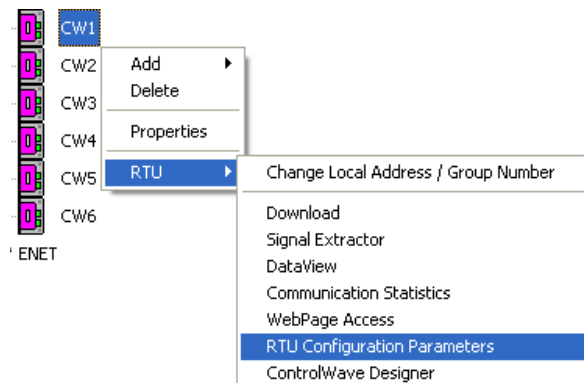

Note: For detailed information on using the Flash Configuration utility, see *Chapter 5 of the OpenBSI Utilities Manual (D5081)*.

- Start the Flash Configuration utility. To do this in NetView or LocalView, *right-click* on the icon for this ControlWave and choose **RTU > RTU Configuration Parameters**.

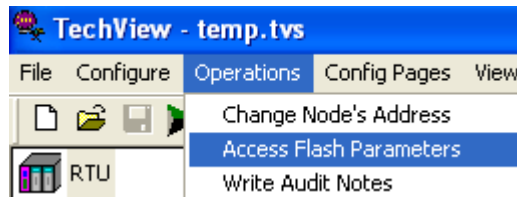

To do this in TechView, click **Operations > Access Flash Parameters** or click the Access Flash icon .



2. Depending upon how your system is configured, the Flash Configuration – Loading Options dialog box may open. If it does, choose **Load from device** and wait for the utility to retrieve all parameters from the ControlWave ExpressPAC, then skip to step 4, otherwise, just proceed to step 3.
3. Click  and wait for the utility to retrieve all parameters from the ControlWave.
4. Click  and specify a name for your FCP file, then click **Save**. When the status line indicates successful completion, your FCP file is done.
5. Copy the resulting FCP file to backup media (CD-ROM, thumb drive, etc.) If you ever need to restore the FCP parameters to the controller, establish communications with the unit, start the Flash Configuration utility, and load the FCP file using the **Read from FCP** button, then choose the **Write to RTU** button.

4.4.3 Backing up Data

You can back up certain types of data and restore it if needed. There are other types of data that you can only collect, but you cannot restore.

- If you have certain variables that represent tuning parameters (setpoints, for example) you can use tools such as the OpenBSI DataView recipe feature to save those values to a recipe file on the PC, and then restore them at a later time. See *Chapter 8* of the *OpenBSI Utilities Manual (D5081)*.
- You can store the contents of read/write data arrays using the OpenBSI Data Array Save/Restore utility. See *Chapter 13* of the *OpenBSI Utilities Manual (D5081)*.
- You can collect alarms, and historical data (audit records, archive files) but you cannot restore alarms or historical data.

Chapter 5 – Service and Troubleshooting

This chapter provides general diagnostic and test information for the ControlWave ExpressPAC, as well as some common maintenance procedures.

In This Chapter

5.1	Upgrading Firmware	5-2
5.2	Removing or Replacing Components.....	5-5
5.2.1	Accessing Modules for Testing	5-5
5.2.2	Removing/Replacing the CPU/System Controller Board and the Process I/O Board	5-5
5.2.3	Removing/Replacing the Primary Battery System	5-6
5.2.4	Removing/Replacing the Backup Battery	5-7
5.2.5	Enabling / Disabling the Backup Battery	5-8
5.2.6	Removing/Replacing the Case-Mounted Radio or Modem	5-9
5.3	General Troubleshooting Procedures	5-9
5.3.1	Checking LEDs.....	5-9
5.3.2	Status Messages on LCD Display.....	5-10
5.3.3	WINDIAG Diagnostic Utility	5-11
5.3.4	Available Diagnostics	5-12
5.4	Core Updump	5-15
5.5	Calibration Checks.....	5-17

Equipment You need the following equipment to perform the procedures described in this chapter:

To run diagnostics software:

- PC with WINDIAG software, and either OpenBSI LocalView, NetView, or TechView for communications
- Null modem interface cable
- Loop-back plug (See *Figure 5-7* and *Figure 5-8*.)

To perform firmware upgrades:

- Null modem interface cable
- PC with the following software:
 - o OpenBSI LocalView
 - o OpenBSI System Firmware Downloader and either NetView, LocalView, or TechView for communications.
 - o HyperTerminal (included in Windows®)

To replace the SRAM backup battery:

- Tweezers or needle-nose pliers

Note: When you service a ControlWave ExpressPAC on site, we recommend that you close down (or place under manual control) any associated processes. This precaution prevents any processes from accidentally running out of control when you conduct tests. Service and repairs should only be performed by qualified

personnel. Any damage to the unit resulting from improper handling or incorrect service is not covered under the product warranty agreement. If qualified personnel are not available, the unit should be returned to the factory (with prior authorization) for evaluation and repairs.

 **Caution** Harmful electrical potentials may still exist at the field wiring terminals even though the ControlWave ExpressPAC power source may be turned off or disconnected. Do not attempt to unplug termination connectors or perform any wiring operations until you verify that all associated power supply sources are turned off and/or disconnected.

Always turn off any external supply sources for externally powered I.O circuits before you change any modules.

5.1 Upgrading Firmware

The ControlWave ExpressPAC ships from the factory with system firmware already installed. If you need to upgrade the system firmware (stored in Flash memory) to acquire new functionality or restore firmware, you can use one of several methods.

System Firmware Downloader

Use this tool to download system firmware to an unattended remote ControlWave ExpressPAC. To use this utility, you must set CPU/System Controller board switch SW2-6 **ON** (the factory default position).

Note: For further information and detailed use instructions, refer to *Appendix J* of the *OpenBSI Utilities Manual* (D5081).

LocalView

One of the standard OpenBSI utilities, LocalView requires OpenBSI version 5.1 (or newer). If you have an older version of OpenBSI, use HyperTerminal.

Note: For further information and detailed use instructions, refer to the Flash Mode section of *Chapter 5* of the *OpenBSI Utilities Manual* (D5081).

HyperTerminal

HyperTerminal is a communications utility program included with Microsoft® Windows® XP.

Notes:

- If you are using a version of OpenBSI older than 5.1, or do not have OpenBSI software, you can only perform a firmware upgrade using HyperTerminal.
 - While HyperTerminal is included in Microsoft® Window® XP, some newer versions of Window® do not include it.
-

- The screens shown here may appear different depending upon the version of HyperTerminal you use.
 - HyperTerminal requires *.BIN files; newer ControlWave firmware upgrade files use *.CAB files. In cases such as those, you should use the Remote System Firmware Downloader.
1. Connect a null modem cable between COM1 of the ControlWave ExpressPAC and any RS-232 port on the associated PC.
 2. Click **Start > Programs > Accessories > Communications > HyperTerminal**
 3. If using HyperTerminal for the first time, set the communication properties (for the PC port) via the Properties Menu as follows: Bits per second: = 115200, Data bits: = 8, Parity: = None, Stop bits: = 1, and Flow control: = None and then click **OK**.
 4. Set CPU/System Controller board switch SW1-3 **ON** (ON = Force Recovery).
 5. Apply power; to the ControlWave ExpressPAC. The resident BIOS initializes and tests the hardware, this process is referred to as POST (Power On Self Test). Unless there is a problem, the LCD display shows “RECOV.” See *Table 5-1* for information on other LCD status messages.
 6. From the HyperTerminal Mode menu (*Figure 5-1*), press the **F** key to enter FLASH download. A message warns that the FLASH is about to be erased; press the **Y** key at the prompt. The screen displays dots as the system erases the flash memory; this could take a few minutes.

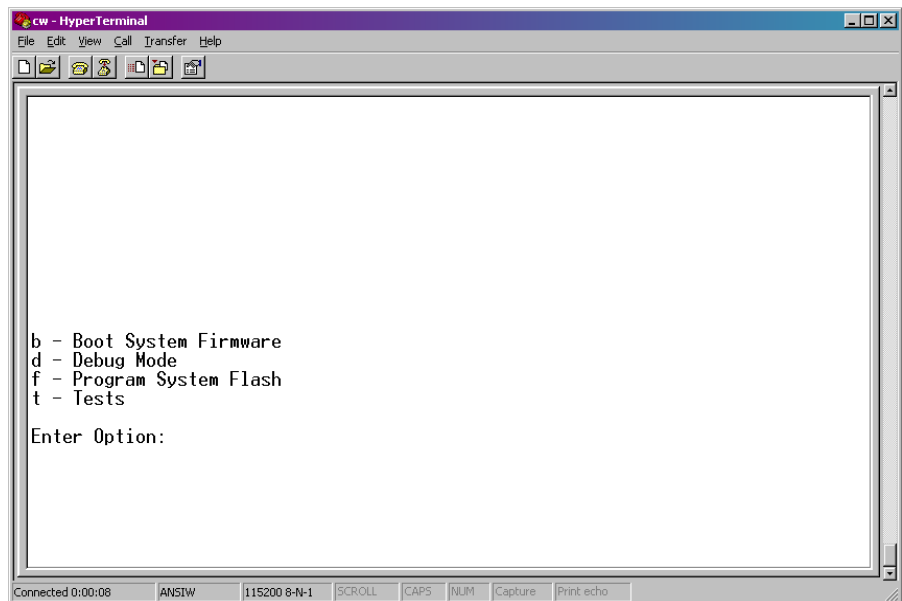

Figure 5-1. HyperTerminal Mode Menu

7. When the FLASH is ready for download, HyperTerminal repeatedly displays the letter C on the screen. In the HyperTerminal menu bar click **Transfer > Send File** (see *Figure 5-2*).

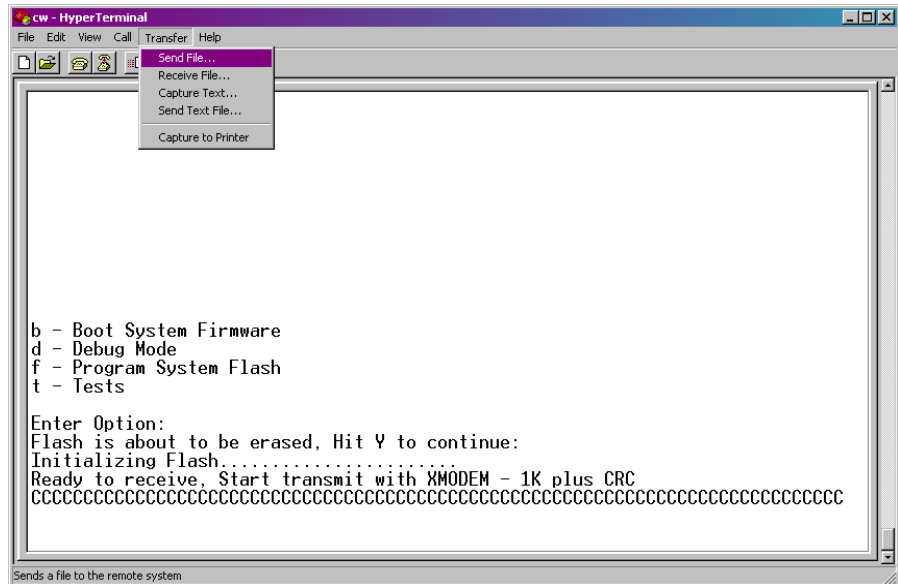

Figure 5-2. HyperTerminal (Ready to Download)

8. In the Send File dialog box (see *Figure 5-3*), select **1KXmodem** for the protocol, enter the filename of the appropriate .bin file in the format "E1Sxxxxx.bin" or "E3Sxxxxxx.bin" (where E1S refers to 14 MHz CPUs, and E3S refers to 33 MHz CPUs and xxxxx varies from release to release) and click **Send** to start the flash upgrade (see *Figure 5-4*). When you see the HyperTerminal Mode Menu again, it means the download has completed.
9. Exit HyperTerminal and power down the ControlWave ExpressPAC. If desired, you can disconnect the null modem cable between the ControlWave ExpressPAC and the PC.
10. Set switch SW1-3 to the **OFF** position (OFF = Recovery Mode Disabled).
11. Restore power to the ControlWave ExpressPAC.

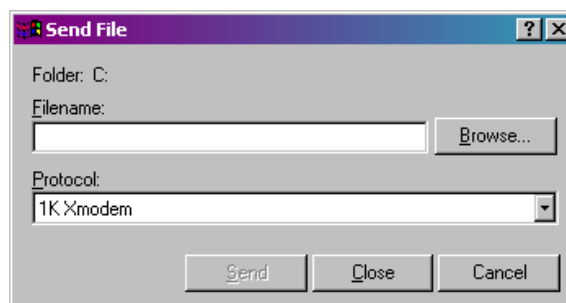

Figure 5-3. Send File dialog box

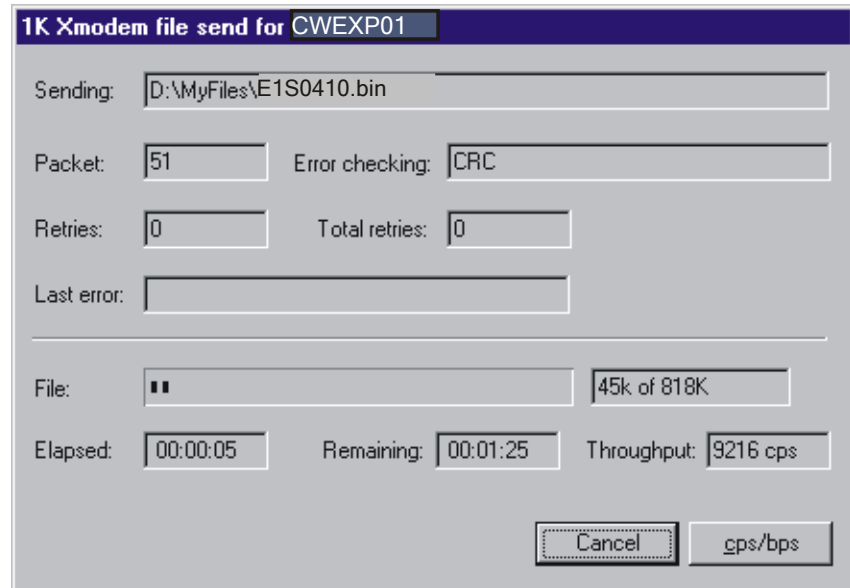

Figure 5-4. HyperTerminal (Download in Progress)

5.2 Removing or Replacing Components

This section provides information on accessing ControlWave ExpressPAC components for testing, as well as removal/replacement procedures.



Caution

Field repairs to the ControlWave ExpressPAC are strictly limited to the replacement of complete boards. Replacing board components constitutes tampering and violates the product warranty. Return defective boards or housings to the factory for authorized service.

5.2.1 Accessing Modules for Testing

Only technically qualified personnel should test and/or replace ControlWave ExpressPAC components. Read completely the disassembly and test procedures described in this manual before starting. Any damage to the ControlWave ExpressPAC resulting from improper handling or incorrect service procedures is not covered under the product warranty agreement. If you cannot properly perform these procedures, obtain authorization and then return the device to the factory for evaluation and repairs.

5.2.2 Removing/Replacing the CPU/System Controller Board and the Process I/O Board

Use this procedure to remove or replace the CPU/System Controller board and the Process I/O board.

1. If the ControlWave ExpressPAC is running, place any critical control processes under manual control.

2. Open the enclosure cover.
3. Shut down the ControlWave ExpressPAC by disconnecting the power at the CPU/System Controller assembly terminal TB1 (and if applicable, TB2).
4. Disconnect all removable card edge connectors from the CPU/System Controller board and the Process I/O board. Label or otherwise identify them so you can easily re-connect them later.
5. If present, disconnect the display/keypad from connector J2 on the CPU/System Controller board.
6. Loosen the upper and lower locking tabs and rotate them so the boards can be removed together.
7. Carefully slide the boards toward the front of the unit and unplug the MVT cable from the CPU/System Controller board connector P1.
8. If you need to replace either the CPU/System Controller board or Process I/O board, you need to separate the two boards. Use a pair of needle-nosed pliers to squeeze the pair of tabs associated with each of the six nylon mounting posts, while gently pulling the CPU/System Controller board away from the Process I/O board. Carefully unplug the boards from their interface connectors.
9. Align the replacement boards with each other and press them together so that the interface connectors and mounting posts properly mate; then squeeze together so that the mounting post tabs capture the CPU/System Controller board.
10. To install the replacement boards, power must be off. Align the Process I/O board with the upper and lower guides so that the CPU/System Controller board is on the right side. Slide the boards (assembly) into the unit, making sure to re-connect the MVT cable to connector P1 on the on the CPU/System Controller board before you fully insert the assembly.
11. Rotate the upper and lower locking tabs to secure the boards.
12. Replace all cables removed in steps 2 through 5.
13. Apply power and test the unit.

5.2.3 Removing/Replacing the Primary Battery System

Note: This procedure refers to the factory-supplied battery system (lithium battery/battery pack or lead acid battery) that provides primary power to the ControlWave ExpressPAC. For information on replacing the SRAM backup battery, see *Section 5.2.4*.

Use this procedure to remove or replace the CPU/System Controller board and the Process I/O board.

1. If the ControlWave ExpressPAC is running, place any critical control processes under manual control.
2. Open the enclosure cover.
3. Shut down the ControlWave ExpressPAC by disconnecting the power at the CPU/System Controller assembly terminal TB1 (and if applicable, TB2).
4. Carefully remove the battery wires from CPU/System Controller board connector TB1 (unplugged in step 3) **making sure they don't contact each other.**
5. Loosen the four screws that secure the battery cover/radio mounting plate to the one piece mounting bracket.
6. Slide the battery cover/radio mounting plate toward the top of the unit so that its slots clear the mounting screws and remove it. If a radio or modem is present, carefully set the battery cover/radio mounting plate to one side. **Note:** Lithium battery systems are located on the inside of the battery cover/radio mounting plate.
7. Carefully remove the primary battery system (with cables attached).
8. To install the new battery system, reverse the steps you did in steps 3 through 7, but perform the reversed steps in reverse order. After you connect power, test the unit.

5.2.4 Removing/Replacing the Backup Battery

Note: The CPU/System Controller board draws power from the backup battery only if the board loses power. The system SRAM has a standby current draw of 20 μA maximum for each part plus 2 μA for the real time clock. For a ControlWave ExpressPAC containing 2MB of SRAM, a worst-case current draw of 42 μA allows a battery life of approximately 9,000 hours. This means you should not need to replace a battery until the ControlWave ExpressPAC has been in service for an extended period (normally many years).

The CPU/System Controller board accommodates a 3 V, 300 mA lithium coin cell backup battery housed in a coin-cell socket (S1). A supervisory circuit on the CPU switches to battery power when the regulated 3.3 Vdc falls out of specification. The battery then provides backup power for the real-time clock (RTC) and the system SRAM on the CPU/System Controller board.

Note: If the real-time clock loses its battery backup, the ControlWave system variable `_QUEST_DATE` turns ON. You can monitor this to generate an alarm. See the *System Variables* section of the *ControlWave Designer Programmer's Handbook* (D5125) for more information.

 **Caution** You lose SRAM contents when you remove the backup battery.

If you replace a backup battery, wait at least one minute before re-powering the system. This enables the SRAM to completely discharge.

After you install the new battery, ensure that you have placed jumper W3 on pins 1-2 (to enable the battery).

Removing / Replacing the Battery

1. If the ControlWave ExpressPAC is running, place any critical control processes under manual control.
2. Remove power from the ControlWave ExpressPAC.
3. Remove the CPU/System Controller board assembly from the housing.
4. To remove the lithium battery, gently pry up the tab holding the battery in the coin cell socket and remove the battery with a pair of tweezers or needle-nosed pliers. Install the replacement battery.
5. Replace the CPU/System Controller board assembly in the housing.
6. Re-connect power to the ControlWave ExpressPAC.
7. Once the battery has been replaced, the unit executes its Flash-based application (“boot project”) at power-up, but all of the current process data is lost. At power-up, the ControlWave ExpressPAC acts as though it had just been booted and reverts back to the initial values specified in its application.

5.2.5 Enabling / Disabling the Backup Battery

For maximum shelf life, the CPU/System Controller board ships from the factory with the installed lithium backup battery disabled. You must enable it when you install the CPU/System Controller board.

Enabling To enable the battery, install jumper W3 on pins 1-2.

Disabling For maximum shelf life, you can isolate the battery from the circuit by placing jumper W3 on pins 2-3.

5.2.6 Removing/Replacing the Case-Mounted Radio or Modem

Use this procedure to remove or replace the case-mounted radio or modem.

1. If the ControlWave ExpressPAC is running, place any critical control processes under manual control.
2. Open the enclosure cover.
3. Shut down the ControlWave ExpressPAC by disconnecting the power at the CPU/System Controller assembly terminal TB1 (and if applicable, TB2).
4. Disconnect (unplug/unscrew) all connectors (power and interface) from the radio/modem.
5. Disconnect the antenna cable from the radio.
6. Loosen the four screws that secure the battery cover/radio mounting plate to the one piece mounting bracket.
7. Slide the battery cover/radio mounting plate toward the top of the unit and remove it with the radio or modem installed.
8. Remove the mounting screws from the inner side of the battery cover/radio mounting plate and remove the radio/modem..
9. To install the new radio/modem, reverse the steps you did in steps 3 through 8, but perform the reversed steps in reverse order. After you connect power, test the unit.

5.3 General Troubleshooting Procedures

This section presents some procedures to troubleshoot problems with the ExpressPAC.

5.3.1 Checking LEDs

The ControlWave ExpressPAC includes two light emitting diodes (LEDs) on the CPU/System Controller board. These are a watchdog LED (WD – CR1 right) and an idle LED (IDLE – CR1 left).

When the watchdog LED is ON (RED) it indicates a program crash; when OFF it indicates normal operation.

When the idle LED is ON (RED) it indicates the CPU has free time at the end of its execution cycle. This should be on frequently. When the idle LED is OFF, it indicates the CPU is overloaded.

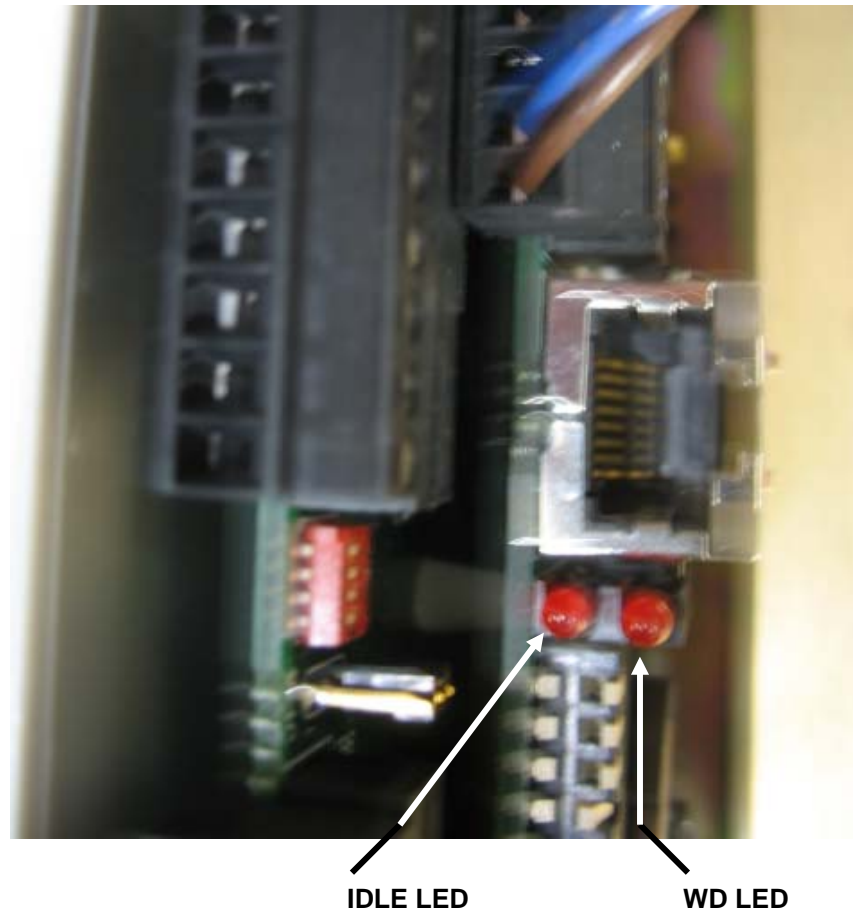

Figure 5-5. WD and IDLE LEDs

The Ethernet port connector (J1) on the CPU/System Controller board contains two LEDs that indicate transmit (yellow) and receive (green) activity when lit.

5.3.2 Status Messages on LCD Display

If your unit includes the optional LCD display, you may see the following status codes.

Table 5-1. LCD Status Codes

LCD Display	Indication / Explanation
Blank	Application running
DIAG	Unit in diagnostic mode
R DIAG	Unit running diagnostics
FWXSUM	Flash XSUM Error
DEVERR	Error initializing application device
FLASH	Flash programming error
FACT	Using factory defaults (flashed at startup)
BATT	Battery failure detected
STRUP	Currently loading the boot project

LCD Display	Indication / Explanation
INIT	System initialization in progress
RECOV	Waiting in recovery mode
RAMERR	Error testing SRAM
STOP	Application loaded
HALT	Stopped at breakpoint
NO APP	No application loaded
BREAKP	Running with breakpoints
POWERD	Waiting for power-down (after NMI)
UPDUMP	Waiting for updump to be performed
NOTRUN	Unit crashed (watchdog disabled)

5.3.3 WINDIAG Diagnostic Utility



Caution

The ControlWave ExpressPAC cannot execute your control strategy while it runs diagnostic routines; place any critical processes controlled by the ControlWave ExpressPAC under manual control before starting this procedure.

WINDIAG is a software-based diagnostic tool you use to test the performance of I/O, CPU memory, communication ports, and other system components. .

WINDIAG is a PC-based program, so the ControlWave ExpressPAC must be attached to and communicating with a PC running WINDIAG. Establish communication between the ControlWave ExpressPAC (with/without an application loaded) and the PC with a local or network port under the following conditions:

- Set CPU module switches SW2-3 to **OFF** and SW2-8 to **OFF**. Turning these switches off sets all serial ports on the ControlWave ExpressPAC to 9600 baud in preparation for diagnostic testing and prevents the boot project from running and also places the ControlWave ExpressPAC in diagnostic mode.
- Connect any ControlWave ExpressPAC serial communication port to the PC provided their port speeds match. Use a null modem cable to connect RS-232 ports between the ControlWave ExpressPAC and the PC; use an RS-485 cable to connect the RS-485 port of the ControlWave ExpressPAC and the PC. See *Chapter 2* for information on cables.
- Reserve the port running a diagnostic test for exclusive use; you cannot use that port for any other purpose during testing.

Follow these steps:

1. Start OpenBSI communications using NetView, TechView, or LocalView, and select the RTU you want to test.
2. Select **Start >Programs > OpenBSI Tools >Common Tools >Diagnostics**. The Main Diagnostics menu (*Figure 5-6*) opens.

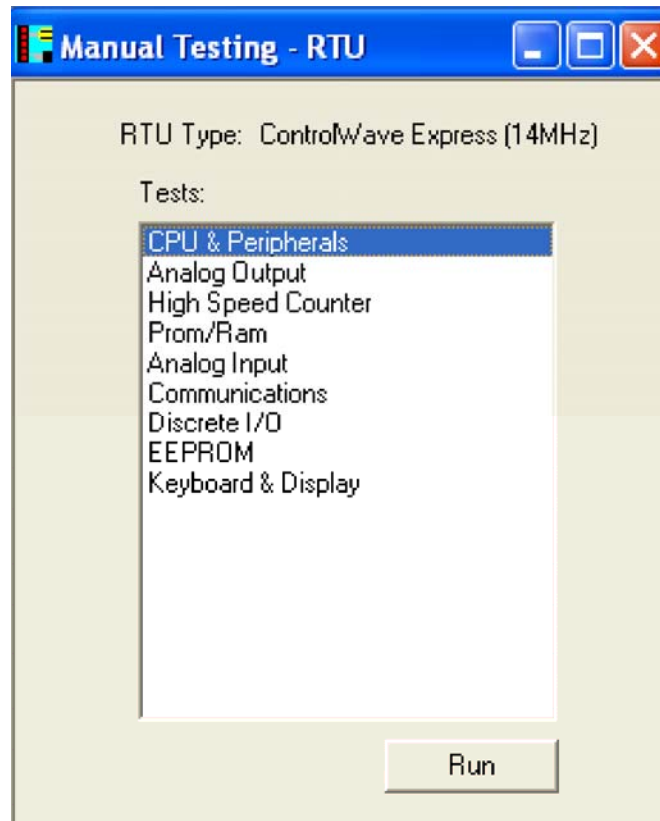

Figure 5-6. WINDIAG Main Diagnostics Menu

3. Select the component to be tested. See *Section 5.3.4* for a description of the tests. Enter any prompted parameters (slot #, etc.). WINDIAG performs the diagnostics and displays pass/fail results.

After performing all diagnostic testing, exit WINDIAG.

4. Set switches SW2-3 and SW2-8 on the CPU module to **ON**. The ControlWave ExpressPAC should resume normal operation.

5.3.4 Available Diagnostics

WINDIAG's Main Diagnostics Menu (see *Figure 5-6*) provides the following diagnostic selections:

Option	Tests
CPU & Peripherals	Checks the CPU/System Controller board except for memory.
Analog Output	Checks the AO on the Process I/O board.
High Speed Counter	Checks HSCs on the Process I/O board and

Option	Tests
	Pulse Counter inputs on the CPU/System Controller board.
Prom/Ram	Checks the SRAM and FLASH memory.
Analog Input	Checks AIs on the Process I/O board.
Communications	Checks serial communication ports COM1, COM2, and COM3. The External loop-back tests require the use of a loop-back plug.
Discrete I/O	Checks DIs and DOs on the Process I/O board.
Ethernet	Checks the Ethernet port.
Keypad & Display	Checks the optional display/keypad hardware.

Port Loop-back Test

WINDIAG allows you to select the communication port to test. Depending on the type of network (RS-232 or RS-485) and the port in question, a special loop-back plug is required:

- Port 1 - RS-232 uses a 9-pin female D-type loop-back plug (see *Figure 5-7*).

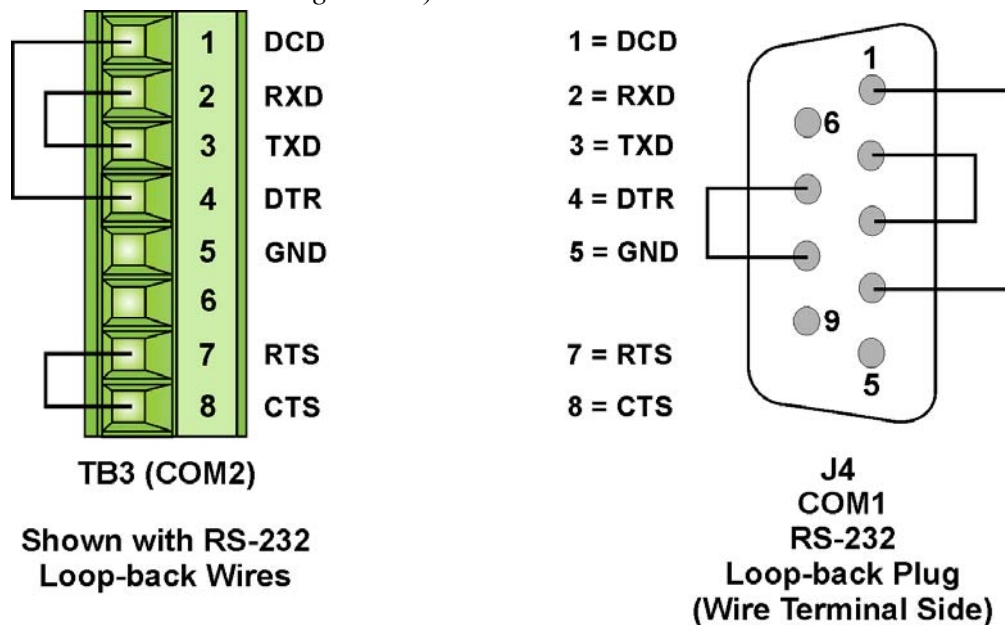

Figure 5-7. COM1 & COM2 RS-232 Loop-back Plug/Wires

- Port 2 - RS-232 use loop-back wires (see *Figure 5-7*).
- Port 3 - RS-232 use loop-back wires (see *Figure 5-8*).

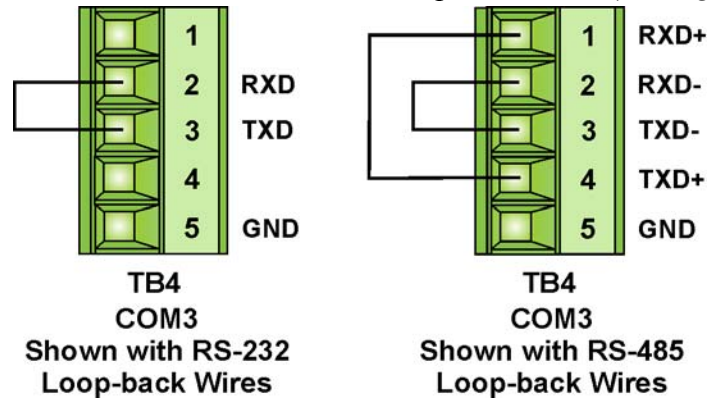

Figure 5-8. COM3 RS-232 & RS-485 Loop-back Wires

Note: You can configure RS-485 loopback by setting CPU/System Controller board switches SW3-1 & SW3-2 **ON**.

- Port 3 - RS-485 use loop-back wires or CPU Switch SW3 (see *Figure 5-8*).

These tests verify the correct operation of the communication ports.

Note: You **cannot** test a communications port while you are using it. You can only test currently unused ports. After you complete testing on all other communication ports (and verify their correct functioning), you must reconnect (using a now validated port) and test the remaining untested port.

Test Procedure Use this procedure to test the communication ports.

1. Connect an external loop-back plug to the port on the CPU you want to test. Valid ports are:
2. Select **Communications** on the WINDIAG Main Diagnostics Menu. The Communications Diagnostic screen opens:

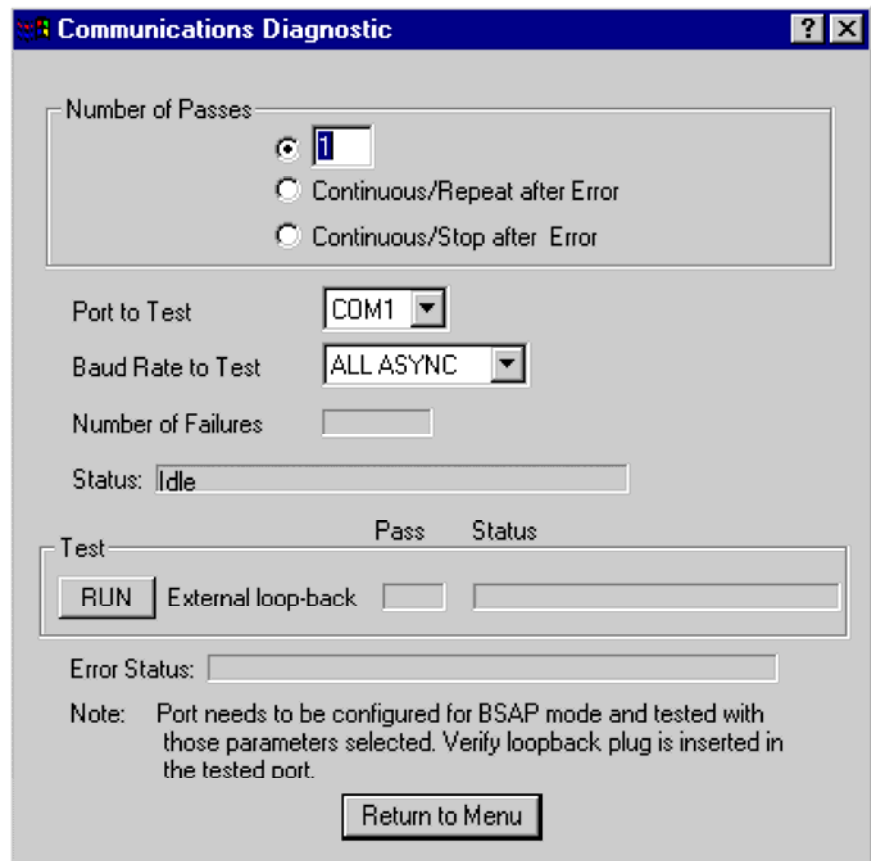

Figure 5-9. Communications Diagnostic Menu

3. Enter **5** in the Number of Passes field.
4. Select a port to test (click ▼ to display all available ports).

Note: The port you select must correlate to the port on which you placed the loop-back plug in step 1.

5. Select **115200** or **ALL ASYNC** as the baud rate (click ▼ to display all available rates).
6. Click **RUN** to start the test. At the completion of the test (which generally takes about 5 seconds), any failed results appear in the Status field to the right of the RUN button:
 - TXD RXD Failure
 - CTS RTS Failure
7. Click **Return to Menu** to display the WINDIAG Main Menu.

5.4 Core Updump

In some cases—such as when a ControlWave ExpressPAC fails for no apparent reason—you can upload a copy of the contents of SRAM and SDRAM to a PC for support personnel and service engineers to evaluate. This upload is called a “core updump.”

A core updump may be required if the ControlWave ExpressPAC spontaneously enters a watchdog state that affects all system operation. This occurs when the system crashes as a result of a CPU timeout (resulting from improper software operation, a firmware glitch, and so on). In some cases, the watchdog state can recur but you cannot logically reproduce the conditions.

The CPU's RAM contains "crash blocks," a firmware function provided specifically for watchdog troubleshooting. You can view and save the crash blocks by viewing the Crash Block Statistic Web Page (see the *Web_BSI Manual*, D5087). On request, you can forward crash block files to our technical support personnel. If they need additional information to evaluate the condition, the technical support group may request a core updump. Once the core updump process generates a file, you can forward that file to the support personnel for evaluation and resolution.

Use the following steps to preserve the "failed state" condition at a system crash and perform a core updump:

1. Set switch SW2-1 on the CPU/System Controller board to **OFF** (Disable Watchdog Timer). If switch SW2-4 is **ON**, set it to **OFF** (Enable Core Updump).

Note: The factory default setting for switch SW2-4 is **OFF**.

2. Wait for the error condition (typically "NOTRUN" on the optional display).
3. Connect the ControlWave ExpressPAC's Comm Port 1 to a PC using a half duplex null modem cable.
4. Set the ControlWave ExpressPAC for Recovery Mode by setting **both** SW1-1 and SW1-2 to the right for open operation or both to the left for closed operation.
5. Start the PC's HyperTerminal program (at 115.2 kbaud) and generate a receive using the 1KX-Modem protocol. Save the resulting core updump in a file so you can forward it later to the technical support group.

By setting the CPU/System Controller board switches SW2-1 and SW2-4 both off **before** the ControlWave ExpressPAC fails you prevent the ExpressPAC from automatically recovering from the failure and enable it to wait for you to take a core updump.

Once you complete the core updump, set the CPU/System Controller board's switch SW2-1 to **ON** (Watchdog Enabled) and SW2-4 to **OFF** (Core Updump Enabled).

Additionally, set switch SW1-1 to **OFF** and SW1-2 to **ON**.

With these switches set, power up the ControlWave ExpressPAC and begin standard operations.

5.5 Calibration Checks

The AO and AI on the Process I/O board are self-calibrating.

To calibrate the RTD, use TechView software. See the *TechView User's Guide* (D5131) for more information.

This page is intentionally left blank

Appendix A – ControlWave ExpressPAC– Special Instructions for Class I, Division 2 Hazardous Locations

1. The ControlWave ExpressPAC RTU is listed by Underwriters Laboratories (UL) as nonincendive and is suitable for use in Class I, Division 2, Groups C and D hazardous locations or non-hazardous locations only. Read this document carefully before installing a nonincendive ControlWave ExpressPAC RTU. Refer to instruction manual *CI-ControlWave EPAC* for general information. In the event of a conflict between *CI-ControlWave EPAC* and this appendix, always follow the instructions in this appendix.
2. The ControlWave ExpressPAC includes both nonincendive and unrated field circuits. Unless a circuit is specifically identified in this document as nonincendive, the circuit is unrated. Unrated circuits must be wired using Div. 2 wiring methods as specified in *Article 501-4(b)* of the *National Electrical Code (NEC)*, *NFPA 70* for installations in the United States, or as specified in *Section 18-152* of the *Canadian Electrical Code* for installation in Canada.
3. The local communications port terminates in a circular 5-pin connector on the bottom of the ControlWave ExpressPAC RTU's instrument front cover. The wiring on this connector is unrated. No connections may be made to this port unless the user ensures that the area is known to be nonhazardous. Connections to this port are temporary, and must be short in duration to ensure that flammable concentrations do not accumulate while it is in use.
4. The optional power system (solar panel and battery) approved for use with the nonincendive ControlWave ExpressPAC RTU are described in the model specification. The connection to the solar panel is approved as a nonincendive circuit so that Division 2 wiring methods are not required. The nominal panel voltage must match the nominal battery voltage (6V or 12V).
5. An RTD is normally supplied with the ControlWave ExpressPAC. Connection to the RTD is approved as a nonincendive circuit, so that Division 2 wiring methods are not required.
6. Signal connectors available for customer wiring are listed in *Table A-1*. Network communication port and I/O wiring connections are unrated and must be wired using Division 2 wiring methods.
7. The UL listed nonincendive ControlWave ExpressPAC RTU may include radio/modem communications (listed on model spec.) that is used in conjunction with a 5W, 12V, 7AH lead acid battery system. Connection to the radio or modem is approved as a nonincendive circuit, so that Division 2 wiring methods are not required.

 WARNING EXPLOSION HAZARD

Do not disconnect solar power from the battery or any other power connections within the ControlWave ExpressPAC enclosure or any power connections to optional items such as radio/modem, or cabling to the display/keypad unless the area is known to be nonhazardous.

 WARNING EXPLOSION HAZARD

Substitution of components may impair suitability for use in Class I, Division 2 environments.

 WARNING EXPLOSION HAZARD

The area must be known to be nonhazardous before servicing/replacing the unit and before installing or removing I/O wiring.

 WARNING EXPLOSION HAZARD

Do NOT disconnect equipment unless power has been disconnected and the area is known to be non-hazardous.

Table A-1. Module/Board Customer Wiring Connectors

Module/Item	Connector	Wiring Notes
CPU/System Controller board	TB1: 6-pin terminal block	Solar power: User wired * Primary power: Factory/User wired * Auxiliary output: Factory/User wired *
CPU/System Controller board	TB3: COM2, 8-pin terminal block RS-232	Remote comm. port: For radio or external network comm. Refer to model spec. and item 6 of this document. When used for network comm. use Div 2 wiring methods. If COM2 is used in conjunction with a radio/modem refer to item 7 of this document.
CPU/System Controller board	TB4: COM3, 5-pin terminal block RS-232/RS-485	RS-232/485 comm. port: For external network comm. Refer to model spec. and item 6 of this document.
CPU/System Controller board	TB5: 4-pin terminal block pulse input interface	Pulse input field wiring: Field I/O wiring connector is unrated, use Div. 2 wiring methods. *
CPU/System Controller board	TB6: 3-pin terminal block RTD interface	Field wired: Refer to item 5 of this document.
CPU/System Controller board	J1: 8-pin RJ-45 jack 10/100Base-T Ethernet port	10/100Base-T Ethernet port jack for external connection to an Ethernet hub. Refer to model spec. and item 6 of this

Module/Item	Connector	Wiring Notes
		document.
CPU/System Controller board	J2: 8-pin RJ-45 female connector – display or display/keypad interface	Factory wired *
CPU/System Controller board	J4: COM1, 9-pin male D-sub RS-232 J11:COM1 3-pin RS-232	RS-232 Comm. Port connectors: For external network comm. Refer to model spec. and item 6 of this document.
CPU/System Controller board	P1: MVT interface	Factory wired *
Process I/O board	TB2: 6-pin terminal block D1 interface	Discrete input field wiring: Field I/O wiring connector is unrated, use Div. 2 wiring methods. *
Process I/O board	TB3: 8-pin terminal block DO/DI interface	Discrete output/input field wiring: Field I/O wiring connector is unrated, use Div. 2 wiring methods. *
Process I/O board	TB4: 8-pin terminal block HSC interface	High speed counter field wiring: Field input wiring connector is unrated, use Div. 2 wiring methods. *
Process I/O board	TB6: 9-pin terminal block AI interface	Analog input field wiring: Field input wiring connector is unrated, use Div. 2 wiring methods. *
Process I/O board	TB7: 4-pin terminal block AO interface	Analog output field wiring: Field output wiring connector is unrated, use Div. 2 wiring methods. *
Front Cover Bottom	Local Port 5-pin female circular connector (present version)	Local Comm. Port – Factory wired. Refer to Item 3 of this document. *

Note: *These wires should only be installed/removed when the item (PCB) in question is installed / removed or when checking wiring continuity. The area must be known to be nonhazardous before servicing / replacing the unit and before installing or removing PCBs, connectors, or individual I/O or power wires. Refer to the warnings in this document. All input power and I/O wiring must be performed in accordance with Class I, Division 2 wiring methods as defined in *Article 501-4(b)* of the *National Electrical Code, NFPA 70*, for installations within the United States, or as specified in *Section 18-152* of the *Canadian Electrical Code* for installation in Canada.

This page is intentionally left blank

Appendix Z – Sources for Obtaining Material Safety Data Sheets

This device includes certain components or materials which may be hazardous if misused. For details on these hazards, please contact the manufacturer for the *most recent* material safety data sheet.

Manufacturer	General Description	Emerson Part Number
DURACELL http://www.duracell.com	3V lithium manganese dioxide battery P/N: DL 2450	395620-01-5
TADIRAN http://www.tadiranbat.com	Two 7.2 Vdc lithium battery packs (Each pack composed of two 3.6V, 35AH batteries.) P/N for individual battery: TL-5137	Battery pack: 395413-01-0
TADIRAN http://www.tadiranbat.com	7.2 Vdc lithium battery pack (Composed of two 3.6V, 35AH batteries.) P/N for individual battery: TL-5137	Battery pack: 395413-01-0
POWER SONIC http://www.power-sonic.com	6V, 7AH lead acid battery – used with 1W, 6V solar panel or 5W, 6V solar panel P/N: PS-670	395407-01-0
POWER SONIC http://www.power-sonic.com	12V, 7AH lead acid battery – used with 5W, 12V solar panel P/N: PS-1270	395407-02-8

This page is intentionally left blank

Index

A

ACCOL3 Firmware Library	1-8
address	
default IP	4-2
Analog Inputs	3-8
Analog Output	3-9

B

Backup battery	
description	1-5
disconnecting	5-8
jumper W3	2-13
removing/replacing	5-7
Backups	4-3
Battery	
replacing	5-7
battery system	
replacing	5-7
Boot FLASH memory	
amount	1-5

C

Cables	
RS-232	2-21
RS-485	2-26
Shielding	3-4
Checking	
LEDs	5-9
Class I, Division 2	2-3, A-1
Communication Ports	
defaults	4-2
Ethernet	2-28
RS-232	2-21
RS-485	2-27
Communications	
Loop-back Test	5-13, 5-14
protocols supported	1-8
ControlWave project	
downloading	4-3
Core Updump	5-15
CPU/System Controller board	
battery backup	5-7
description	1-4
jumpers	2-13
replacing	5-5
switches	2-11

D

Defaults	
Comm Ports	4-2
Diagnostic software	5-11

Disconnecting RAM Battery	5-8
Discrete Inputs	3-6
Discrete Outputs	3-7
Display/Keypad	2-29
status message appearing on	5-10
Downloading	
the ControlWave project	4-3

E

Environmental specifications	2-3
Ethernet Port	2-28

F

Features	1-1
Field repair	5-5
Figures	
1-1. ControlWave ExpressPAC Enclosure	1-3
1-2. ControlWave Programming Environment	1-7
2-1. ControlWave ExpressPAC Component Identification	2-2
2-2. ControlWave ExpressPAC enclosure dimensions	2-5
2-3. ControlWave ExpressPAC Bottom View	2-6
2-4. Side View of ControlWave ExpressPAC (Mounted to a 2	2-7
2-5. Side View of ControlWave ExpressPAC (Wall or Panel Mounted)	2-8
2-6. CPU/System Controller Board Component I.D. Diagram	2-10
2-7. CPU/ System Controller Board (TB1 & TB2) Power Wiring	2-16
2-8. 1 Watt Solar Panel Mounting Diagram	2-19
2-9. 5 Watt Solar Panel Mounting Diagram	2-20
2-10. Male DB9 9-Pin Connector	2-21
2-11. Full-duplex and Half-duplex Cable	2-23
2-12. Full-duplex and Half-duplex Cable	2-24
2-13. Connection from Modem/Radio to COM2 of the ControlWave ExpressPAC	2-24
2-14. Full-duplex and Half-duplex Cable	2-25
2-15. PC Connected to ControlWave ExpressPAC via Circular Local Port	2-25
2-16. RJ-45 Ethernet Connector	2-28
2-17. Standard 10/100Base-T Ethernet Cable (CPU Module to Hub)	2-28
2-18. Point-to-Point 10/100Base T Ethernet Cable	2-29
2-19. Optional 2-Button and 25-Button Keypads	2-30
2-20. Display with No Keypad	2-30
3-1. Process I/O Board Component Identification diagram	3-3
3-2. Process I/O Board Wiring Diagrams	3-5
3-3. Pulse Input Wiring diagram	3-10

3-4. 3-Wire RTD Temperature Input Wiring . 3-12
 3-5. RTD Probe Installation/Removal diagram .3-13
 3-6. 3808 Transmitter to ControlWave ExpressPAC RS-232 Comm. Cable Diagram.3-14
 3-7. 3808 Transmitter to ControlWave ExpressPAC RS-485 Comm. Cable 3-15
 3-8. ControlWave ExpressPAC to 3808s - RS-485 Network Diagram 3-15
 4-1. Saving a Backup of Your Project 4-4
 5-1. HyperTerminal Mode Menu 5-3
 5-2. HyperTerminal (Ready to Download)..... 5-4
 5-3. Send File dialog box..... 5-4
 5-4. HyperTerminal (Download in progress) .. 5-5
 5-5. WD and IDLE LEDs 5-10
 5-6. WINDIAG Main Diagnostics Menu..... 5-12
 5-7. COM1 & COM2 RS-232 Loop-back Plug/Wires 5-13
 5-8. COM3 RS-232 & RS-485 Loop-back Wires 5-14
 5-9 Communications Diagnostic menu 5-15
 Firmware upgrade..... 5-2
 HyperTerminal..... 5-2
 LocalView 5-2
 System Firmware Downloader 5-2
 FLASH memory
 amount..... 1-5

G

Grounding 2-9, 3-4

H

Hazardous locations
 special instructions for..... A-1
 High Speed Counter/Discrete Inputs 3-11
 Humidity
 specifications 2-3
 HyperTerminal 5-2

I

I/O Configurator 1-7
 I/O Options..... 1-6
 I/O Wiring..... 3-1, 3-4
 Installation..... 3-4
 Class 1, Div 2 2-3
 Overview 2-3
 IP address
 default..... 4-2

J

Jumpers
 CPU/System Controller board..... 2-13
 Process I/O Board 3-2

K

Keypad/Display 2-29

L

LEDs
 Checking..... 5-9
 disabling 2-11
 LocalView..... 5-2
 Loop-back Test 5-13, 5-14

M

Material Safety Data Sheets (MSDS)
 how to obtain Z-1
 Memory
 Boot FLASH..... 1-5
 FLASH amount 1-5
 SRAM amount 1-6
 Mounting the housing 2-4

O

Operator's keypad/display 2-29

P

Power
 connecting or disconnecting 4-2
 wiring 2-14
 Power connector TB1 2-16
 Power connector TB2 2-17
 Process I/O board
 configurations 1-6, 3-1
 Jumpers..... 3-2
 replacing 5-5
 switches..... 3-2
 Protocols
 supported in ControlWave..... 1-8
 Pulse Counter/Discrete Inputs 3-10

R

radio/modem
 replacing 5-9
 RAM Battery
 Disconnecting 5-8
 Recovery mode switches..... 2-11
 Repair in field 5-5
 Resistance Temperature Device (RTD) 3-12
 RS-232 Ports 2-21
 Cables 2-21
 RS-485 Ports 2-27
 Cables 2-26
 configuration switch 2-12
 Running diagnostic software..... 5-11

S

Site Considerations..... 2-1
 Soft Switches

lock/unlock switch.....	2-11
use/ignore switch.....	2-11
Software Tools.....	1-7
Specifications	
for temperature, humidity, vibration.....	2-3
SRAM memory	
amount.....	1-6
control switch.....	2-12
Status messages	
on LCD display	5-10
Switches	
CPU	2-11
Process I/O board	3-2
System Firmware Downloader.....	5-2

T

Tables

1-1. CPU/System Controller board Variations	1-5
1-2. Process I/O Configurations	1-6
2-1. CPU/System Controller Bd Switch SW12	11
2-2. CPU/System Controller Bd Switch SW22	11
2-3. RS-485 Configuration Switch (SW3)....	2-12
2-4. Bulk Power Requirements.....	2-15
2-5. Solar Panel Tilt Angle.....	2-18
2-6. RS-232 Connectors.....	2-21
2-7. RS-232 Port Connector Pin Assignment	2-22
2-8. RS-232 Port Alternate Connector Pin Assignment.....	2-22
2-9. COM3 RS-485 Connector	2-26
2-10. COM3 Connector Pin Assignment	2-26
2-11. RS-485 Network Connections.....	2-27
2-12. Ethernet 10/100Base-T CPU Module Pin Assignments.....	2-28
3-1. Process I/O Configurations	3-1
3-2. Process I/O Board Switch SW1	3-2
3-3. Non-Isolated DI General Characteristics	3-6
3-4. Non-Isolated DO General Characteristics	3-7
3-5. Non-Isolated AI General Characteristics.	3-8
3-6. Non-Isolated AO General Characteristics	3-9

3-7. Non-Isolated Pulse Counter/Discrete Inputs General Characteristics.....	3-10
3-8. Non-Isolated High Speed Counter/Discrete Inputs General Characteristics.....	3-11
3-9. RTD Connections to CPU/System Controller Board Connector TB6.....	3-12
4-1. Default Comm Port Settings (by PCB)....	4-2
5-1. LCD Status Codes.....	5-10
A-1. Module/Board Customer Wiring Connectors	A-2
TB1 Connector.....	2-16
TB2 Connector.....	2-17
Temperature	
specifications	2-3
Tools	5-1
Transmitters	
connecting	3-14
Troubleshooting	5-1
general.....	5-9

U

Updump	5-15
switch.....	2-11
Upgrading firmware.....	5-2

V

Vibration	
specifications	2-3

W

W3 Backup battery jumper	2-13
Watchdog	
enable switch.....	2-11
WINDIAG	5-11
Wiring	
I/O	3-1, 3-4

ControlWave ExpressPAC

**Emerson Process Management
Remote Automation Solutions**

1100 Buckingham Street
Watertown, CT 06795
Phone: +1 (860) 945-2262
Fax: +1 (860) 945-2525
www.EmersonProcess.com/Remote

**Emerson Process Management
Remote Automation Solutions**

6338 Viscount Rd.
Mississauga, Ont. L4V 1H3
Canada
Phone: 905-362-0880
Fax: 905-362-0882
www.EmersonProcess.com/Remote

Emerson Process Management SA de CV

Calle 10 #145
Col. San Pedro de los Pinos
01180 Mexico, D.F.
Mexico
T +52 (55) 5809-5300
F +52 (55) 2614-8663
www.EmersonProcess.com/Remote

**Emerson Process Management, Ltd.
Remote Automation Solutions**

Blackpole Road
Worcester, WR3 8YB
United Kingdom
Phone: +44 1905 856950
Fax: +44 1905 856969
www.EmersonProcess.com/Remote

**Emerson Process Management AP Pte Ltd.
Remote Automation Solutions Division**

1 Pandan Crescent
Singapore 128461
Phone: +65-6770-8584
Fax: +65-6891-7841
www.EmersonProcess.com/Remote

NOTICE

“Remote Automation Solutions (“RAS”), division of Emerson Process Management shall not be liable for technical or editorial errors in this manual or omissions from this manual. RAS MAKES NO WARRANTIES, EXPRESSED OR IMPLIED, INCLUDING THE IMPLIED WARRANTIES OF MERCHANTABILITY AND FITNESS FOR A PARTICULAR PURPOSE WITH RESPECT TO THIS MANUAL AND, IN NO EVENT SHALL RAS BE LIABLE FOR ANY INCIDENTAL, PUNITIVE, SPECIAL OR CONSEQUENTIAL DAMAGES INCLUDING, BUT NOT LIMITED TO, LOSS OF PRODUCTION, LOSS OF PROFITS, LOSS OF REVENUE OR USE AND COSTS INCURRED INCLUDING WITHOUT LIMITATION FOR CAPITAL, FUEL AND POWER, AND CLAIMS OF THIRD PARTIES.

Bristol, Inc., Bristol Babcock Ltd, Bristol Canada, BBI SA de CV and the Flow Computer Division are wholly owned subsidiaries of Emerson Electric Co. doing business as Remote Automation Solutions (“RAS”), a division of Emerson Process Management. FloBoss, ROCLINK, Bristol, Bristol Babcock, ControlWave, TeleFlow and Helicoid are trademarks of RAS. AMS, PlantWeb and the PlantWeb logo are marks of Emerson Electric Co. The Emerson logo is a trademark and service mark of the Emerson Electric Co. All other trademarks are property of their respective owners.

The contents of this publication are presented for informational purposes only. While every effort has been made to ensure informational accuracy, they are not to be construed as warranties or guarantees, express or implied, regarding the products or services described herein or their use or applicability. RAS reserves the right to modify or improve the designs or specifications of such products at any time without notice. All sales are governed by RAS’ terms and conditions which are available upon request.

© 2011 Remote Automation Solutions, division of Emerson Process Management. All rights reserved.