

S800 I/O

Fieldbus Communication Interface for PROFIBUS DP/DPV1

Power and productivity
for a better world™



S800 I/O

Fieldbus Communication Interface for PROFIBUS DP/DPV1

NOTICE

This document contains information about one or more ABB products and may include a description of or a reference to one or more standards that may be generally relevant to the ABB products. The presence of any such description of a standard or reference to a standard is not a representation that all of the ABB products referenced in this document support all of the features of the described or referenced standard. In order to determine the specific features supported by a particular ABB product, the reader should consult the product specifications for the particular ABB product.

ABB may have one or more patents or pending patent applications protecting the intellectual property in the ABB products described in this document.

The information in this document is subject to change without notice and should not be construed as a commitment by ABB. ABB assumes no responsibility for any errors that may appear in this document.

In no event shall ABB be liable for direct, indirect, special, incidental or consequential damages of any nature or kind arising from the use of this document, nor shall ABB be liable for incidental or consequential damages arising from use of any software or hardware described in this document.

This document and parts thereof must not be reproduced or copied without written permission from ABB, and the contents thereof must not be imparted to a third party nor used for any unauthorized purpose.

The software or hardware described in this document is furnished under a license and may be used, copied, or disclosed only in accordance with the terms of such license. This product meets the requirements specified in EMC Directive 2004/108/EC and in Low Voltage Directive 2006/95/EC.

TRADEMARKS

All rights to copyrights, registered trademarks, and trademarks reside with their respective owners.

Copyright © 2003-2013 by ABB.
All rights reserved.

Release: May 2013
Document number: 3BSE020926-510 A

TABLE OF CONTENTS

About This Book

General	11
Document Conventions	11
Warning, Caution, Information, and Tip Icons	11
Terminology.....	12
Related Documentation	14

Section 1 - Introduction

Product Overview	16
Product Scope.....	16

Section 2 - Installation

Section 3 - Configuration

CI801 FCI.....	31
Address Switches	31
PROFIBUS Connection	32
Power Supply Connections	34
CI830 FCI.....	35
Address Switches	35
PROFIBUS-DP Connections	35
Power Supply Connections	37
CI840 FCI.....	38
Address Switches	38
PROFIBUS Connections.....	39
Power Supply Connections	41

Configuration and Performance	42
CI801 Configuration Rules	42
CI830 Configuration Rules	47
CI840 Configuration Rules	51
Supported I/O Modules and Drives via PROFIBUS and CI801	56
Supported I/O Modules and Drives via PROFIBUS and CI830	57
Supported I/O Modules via PROFIBUS and CI840	58
Data Scanning	59

Section 4 - Operation

Operating Overview	63
Getting Started	63
Functional Description	63
I/O Module Functionality	67

Section 5 - Maintenance

Preventive Maintenance	73
Hardware Indicators	73
CI801 FCI Module LEDs	73
CI830 FCI Module LEDs	75
CI840 FCI Module LEDs	77
Error Messages	78
Fault Finding and Repair	79
Communication Module Replacement	79
Application Memory Reset	83
CI801 Firmware version	83
CI840 Firmware version	84
Backup/Restore Procedures	84
Load the CI801 Software Upgrade	84
Load the CI830 Software Upgrade	87
Load the CI840 Software Upgrade	89

Appendix A - Specifications

CI801 Fieldbus Communications Interface (FCI)	95
Features	95
Description	95
Technical Data.....	96
Dimensions.....	98
Connections.....	98
Block Diagram CI801	100
CI830 Fieldbus Communications Interface (FCI)	101
Features	101
Description	101
Technical Data.....	102
Dimensions.....	104
Connections.....	104
Block Diagram CI830	107
CI840 Fieldbus Communications Interface (FCI)	108
Features	108
Description	108
Technical Data.....	111
Connections.....	112
Block Diagram CI840, single ModuleBus	113
Block Diagram CI840, dual ModuleBus.....	114
TU846 Redundant MTU for CI840, dual ModuleBus	115
Features	115
Description	115
Technical Data.....	116
Dimensions.....	117
Connections	118
Block Diagram TU846.....	120
TU847 Redundant MTU for CI840, single ModuleBus.....	121
Features	121
Description	121
Technical Data.....	122

Dimensions 123
Connections 124
Block Diagram TU847..... 126

INDEX

Safety Summary



Electrostatic Sensitive Device

Devices labeled with this symbol require special handling precautions as described in the installation section.

GENERAL WARNINGS

Equipment Environment

All components, whether in transportation, operation or storage, must be in a noncorrosive environment.

Electrical Shock Hazard During Maintenance

Disconnect power or take precautions to insure that contact with energized parts is avoided when servicing.

SPECIFIC CAUTIONS

Page-81: If the last CI801 on a PROFIBUS segment supplies an active termination in the cable connector, disconnection of the power supply or the PROFIBUS cable to CI801 can not be done without disrupting the bus.

Page-82: If the last CI830 on a PROFIBUS segment supplies an active termination in the cable connector, disconnection of the power supply or the PROFIBUS cable to CI830 can not be done without disrupting the bus.

Page-82: If the last CI840 on a PROFIBUS segment supplies an active termination in the cable connector, disconnection of the power supply or the PROFIBUS cable to CI840 can not be done without disrupting the bus.

Safety Summary

About This Book

General

This book provides a description of the S800 field communication using PROFIBUS-DP/DPV1. It provides instructions for site planning and installation, start-up and shutdown procedures, and information regarding capacity and performance. This book is not intended to be the sole source of instruction for the S800 I/O system.

Document Conventions

Microsoft Windows conventions are normally used for the standard presentation of material when entering text, key sequences, prompts, messages, menu items, screen elements, etc.

Warning, Caution, Information, and Tip Icons

This publication includes **Warning**, **Caution**, and **Information** where appropriate to point out safety related or other important information. It also includes **Tip** to point out useful hints to the reader. The corresponding symbols should be interpreted as follows:



Electrical warning icon indicates the presence of a hazard which could result in *electrical shock*.



Warning icon indicates the presence of a hazard which could result in *personal injury*.



Caution icon indicates important information or warning related to the concept discussed in the text. It might indicate the presence of a hazard which could result in *corruption of software or damage to equipment/property*.



Information icon alerts the reader to pertinent facts and conditions.



Tip icon indicates advice on, for example, how to design your project or how to use a certain function

Although **Warning** hazards are related to personal injury, and **Caution** hazards are associated with equipment or property damage, it should be understood that operation of damaged equipment could, under certain operational conditions, result in degraded process performance leading to personal injury or death. Therefore, **fully comply** with all **Warning** and **Caution** notices.

Terminology

A complete and comprehensive list of Terms is included in the Industrial^{IT} Extended Automation System 800xA, Engineering Concepts instruction (3BDS100972*). The listing included in Engineering Concepts includes terms and definitions as they that apply to the 800xA system where the usage is different from commonly accepted industry standard definitions and definitions given in standard dictionaries such as *Webster's Dictionary of Computer Terms*.

Term	Description
Base cluster	Consists of single or redundant FCIs plus I/O modules connected directly to the FCI.
FCI	The Fieldbus Communication Interface (FCI) device contains the interface to the fieldbus PROFIBUS-DP/DPV1, ModuleBus interface and power regulators. The FCI module can manage 24 I/O devices (up to 12 directly and to the others in 1 to 7 I/O clusters).
HCIR	Hot Configuration In Run, possibility to change configuration in a running system.

Term	Description
I/O cluster	An extension of the I/O Station's ModuleBus connected to the FCI by fiber optic connections. Up to 12 I/O devices per cluster.
I/O device	A complete I/O device consists of one MTU and one I/O module.
I/O module	Is an active, electronic and signal conditioning unit. Can be a part of an I/O device or a S800L I/O module.
I/O station	An I/O station consists of a base cluster with single or redundant FCI(s), 1-7 I/O clusters and up to 24 I/O devices.
I.S.	Intrinsic Safety is a protection technique to prevent explosion in hazardous areas of a process plant.
ModuleBus	Is an incremental, electrical or optical, bus for interconnection of I/O devices.
(ModuleBus) Extension cable	Is used when extending the electrical ModuleBus (within the max. 2.5 meters 8.2").
MTU	The Module Termination Unit is a passive base unit containing process terminals and a part of the ModuleBus.
OSP	Outputs Set as Predetermined. A user configurable action on an output module when communications is lost to the FCI or Controller.
PROFIBUS-DP	PROFIBUS-DP is a fieldbus standard.
PROFIBUS-DPV1	PROFIBUS-DPV1 is a fieldbus standard.
PROFIBUS	Stands for both PROFIBUS-DP and PROFIBUS-DPV1.
TC	Thermocoupler

Related Documentation

The following is a listing of documentation related to Fieldbus Communication Interface for PROFIBUS-DP/DPV1.

Table 1. Related Documentation

Title	Description
S800 I/O Getting Started	Describes the general installation and configuration information for the S800 I/O system.
S800 I/O Modules and Termination Units	Describes the I/O modules and termination units in the S800 I/O system.
S800 I/O Modules and Termination Units with Intrinsic Safety Interface	Describes the I/O modules and termination units with I.S. interface in the S800 I/O system.
S800 I/O PROFIBUS FCI Memory Maps for CI801	Describes the memory mapping on PROFIBUS-DPV1 in CI801 for the S800 I/O system.
S800 I/O PROFIBUS FCI Memory Maps for CI830	Describes the memory mapping on PROFIBUS-DP in CI830 for the S800 I/O system.
S800 I/O PROFIBUS FCI Memory Maps for CI840	Describes the memory mapping on PROFIBUS-DPV1 in CI840 for the S800 I/O system.

Section 1 Introduction

The S800 I/O is distributed modular I/O which communicates with numerous controllers over a Advant Fieldbus 100 (AF100), PROFIBUS-DP/DPV1 or directly. The S800 I/O provides easy installation of the I/O modules and process cabling. It is highly modularized and flexible so that I/O modules can be combined to suit many applications. The S800 I/O can be mounted in many configurations to fit most requirements.

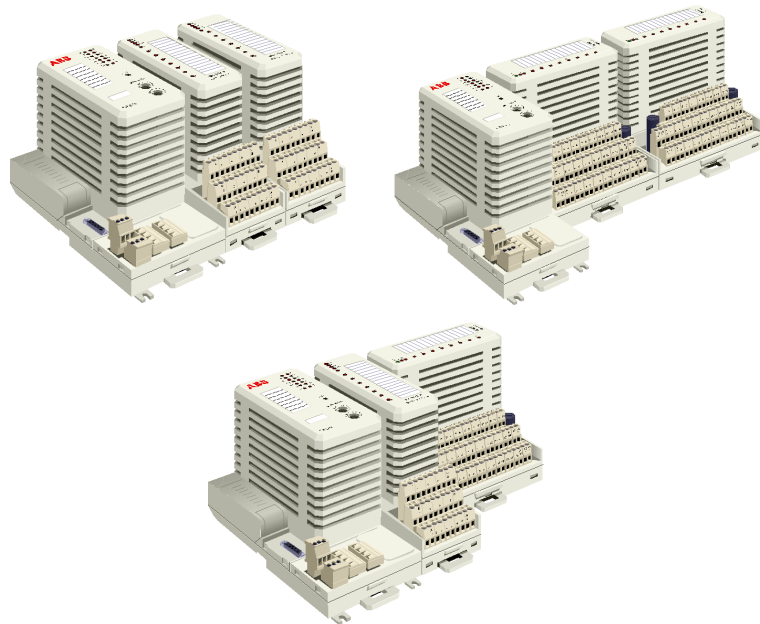

Figure 1. S800 I/O Fieldbus Communication Interface with an I/O Module on Compact and Extended MTUs

Product Overview

The S800 I/O provides easy installation of the I/O modules and process cabling. It is highly modularized and flexible so that the I/O modules can be combined to suit many applications. The S800 I/O modules and a Fieldbus Communication Interface (FCI) are combined to form an I/O Station.

In general all S800 units are G3 compliant. G3 compliant modules withstand more severe environmental conditions according to ISA-S71.04. The following S800 units are G2 compliant - SD821, SD822, SD823, SD831, SD832, SD833, SD834, SS822, SS832, TB811 and CI830. G3 compliant versions of SD822 and SS822 are available (refer to SD822Z and SS822Z).

The standards referred to are followed in applicable parts which are described in this manual.

For more overview information refer *S800 I/O Getting Started (3BSE020923*)*.

Product Scope

CI801 Fieldbus Communications Interface (FCI)

The CI801 Fieldbus Communication Interface (FCI) module is a configurable communication interface which performs operations such as signal processing, gathering of various supervision information, OSP handling and configuration of I/O modules. The FCI connects to a controller by way of the PROFIBUS-DPV1 fieldbus.

The FCI has one PROFIBUS-DPV1 interface and uses a PROFIBUS-DP cable with a total length of up to 1200 meters (1312 yards). Up to 32 stations can be configured on one segment. The station address sets by rotary switches that select the address on the fieldbus in the range of 01 to 99.

The FCI modules are DIN rail mounted and have connections for input power, PROFIBUS and two rotary switches for station address selection.

An I/O Station can consist of the FCI modules, ModuleBus Modems and the I/O modules. The FCI is the bus-master on the S800 I/O ModuleBus and communicates with the S800 I/O modules. It is a pure “slave station” on PROFIBUS-DPV1 which is controlled by a master station.

I/O Station modules are mounted on DIN rails and are connected by the ModuleBus. [Figure 2](#) shows the FCI modules connected to the Optical ModuleBus Port TB842.

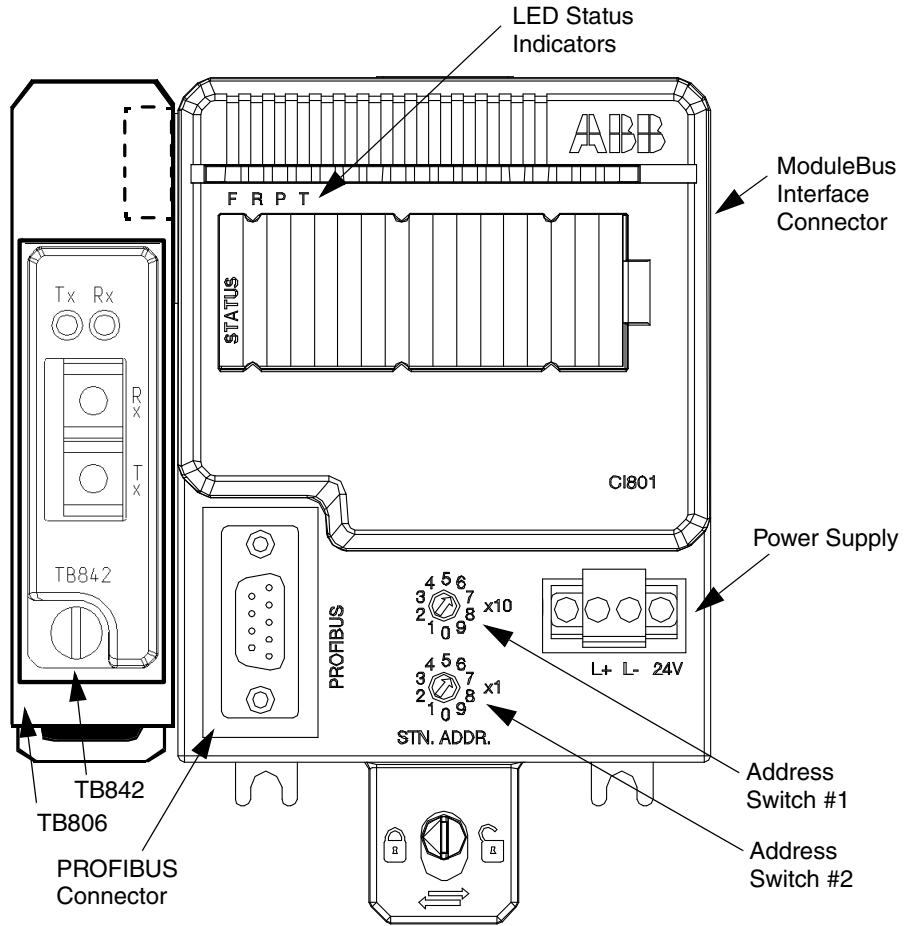

Figure 2. CI801 FCI Module and TB842 Optical ModuleBus Port

The FCI communicates with the PROFIBUS Master, ModuleBus Modems and the I/O modules. The FCI handles the I/O-modules operations such as read and write data, read status and configuration of modules and channels. The FCI has a connection to the TB842 Optical ModuleBus Port mounted on a TB806 to the left, see [Figure 2](#).

The FCI provides 24 V d.c. (from the source) and an isolated 5 V d.c power to the base cluster's I/O modules (12 maximum) by way of the ModuleBus connections. One power source 24 V d.c. can be connected to the power terminals (L+ & L-).

The power source is supervised by the POWER OK status LED.

The size, type and direction of data to be transferred on the PROFIBUS-DP bus depends on and is determined by the I/O module type. The FCI can be configured to send or transmit dynamic data over the PROFIBUS-DP with cycle times in the interval from 1 ms.

CI830 Fieldbus Communications Interface (FCI)

The CI830 Fieldbus Communication Interface (FCI) module is a configurable communication interface for single configurations which performs operations such as signal processing, gathering of various supervision information, OSP handling and configuration of I/O modules. The FCI connects to a controller by way of the PROFIBUS-DP fieldbus.

The FCI has one PROFIBUS-DP interface and uses a PROFIBUS-DP cable with a total length of up to 1200 meters (1312 yards). Up to 32 stations can be configured on one segment. The FCI has two rotary switches that select its address on the fieldbus in the range of 01 to 79.

An I/O Station can consist of the FCI module, ModuleBus Modems and the I/O modules. The FCI is the bus-master on the S800 I/O ModuleBus and communicates with the S800 I/O modules. It is a pure "slave station" on PROFIBUS-DP which is controlled by a master station.

I/O Station modules are mounted on DIN rails and are connected by the ModuleBus. This principle allows horizontal and vertical mounting on the wall. Figure 3 shows the FCI Module.

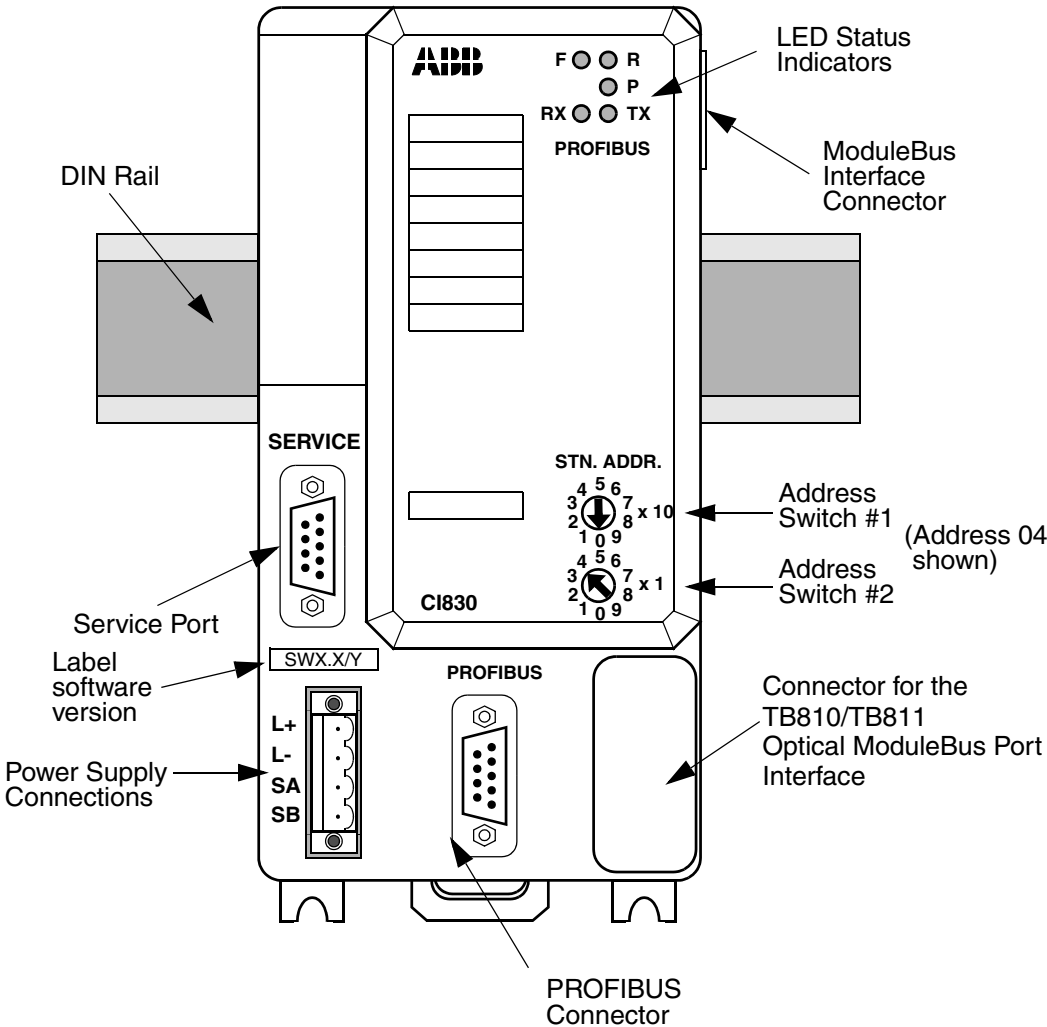

Figure 3. CI830 FCI Module

The FCI communicates with the PROFIBUS Master, ModuleBus Modems and the I/O modules. The FCI handles the I/O-modules operations such as read and write data, read status and configuration of modules and channels. The FCI has a connector for the TB810/TB811 Optical ModuleBus Port.

The FCI provides 24 V d.c. (from the source) and an isolated 5 V d.c. power to the base cluster's I/O modules (12 maximum) by way of the ModuleBus connections. One power source (single or redundant 24 V d.c.) can be connected to the power terminals (L+ & L-) of the FCI.

1:1 redundant power sources can be supervised by connecting the power sources POWER OK status signals to terminals SA and SB.

The size, type and direction of data to be transferred on the PROFIBUS-DP bus depends on and is determined by the I/O module type. The FCI can be configured to send or transmit dynamic data over the PROFIBUS-DP with cycle times in the interval from 1 ms.

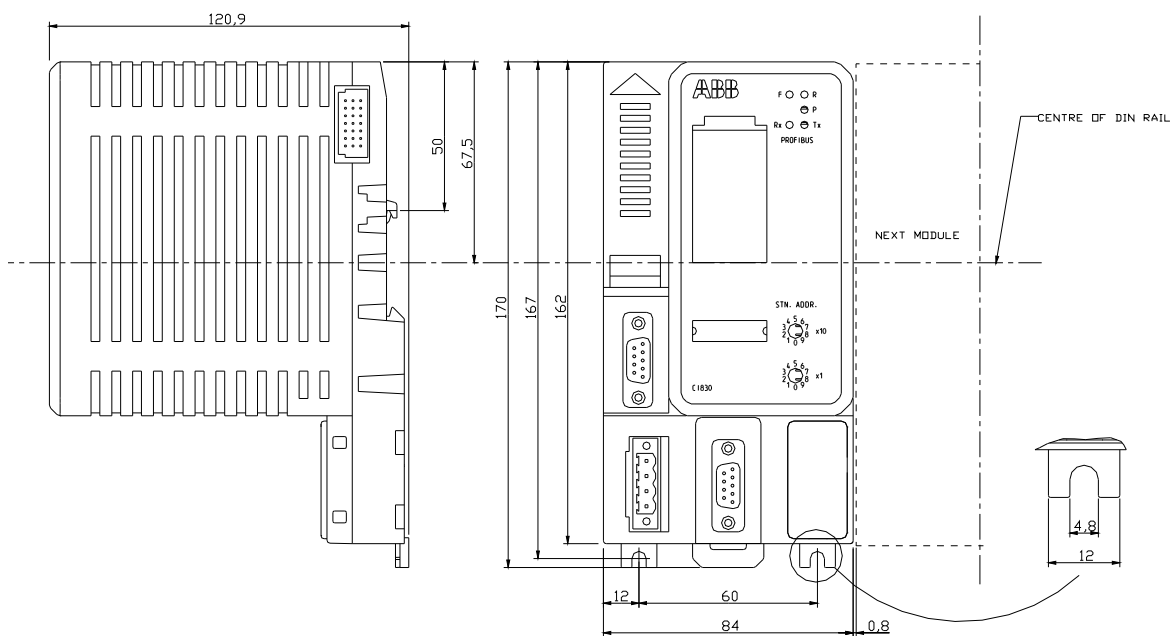

Figure 4. CI830 FCI Dimensions

CI840 Fieldbus Communications Interface (FCI)

The CI840 Fieldbus Communication Interface (FCI) module is a configurable communication interface which performs operations such as signal processing, gathering of various supervision information, OSP handling and configuration of I/O modules. The FCI connects to a controller by way of the PROFIBUS-DPV1 fieldbus.

CI840 is designed for redundant applications. One CI840 works as a primary FCI and the other as a backup. Both FCIs supervises each other. If a fault occurs in the primary FCI, it results in an automatic switch over to the backup CI840.

The FCI has one PROFIBUS-DPV1 interface and uses a PROFIBUS-DP cable with a total length of up to 1200 meters (1312 yards). Up to 32 stations can be configured on one segment. The station address sets by rotary switches that select the address on the fieldbus in the range of 01 to 99, in redundant configurations 1 to 62.

The FCI modules are mounted on a Module Termination Unit TU846 or TU847. TU846/TU847 are DIN rail mounted and have connections for input power, PROFIBUS, service tool and two rotary switches for station address selection.

TU847 with CI840 are used for single I/O applications and TU846 with CI840 are used for redundant applications.

An I/O Station can consist of the FCI modules, ModuleBus Modems and the I/O modules. The FCI is the bus-master on the S800 I/O ModuleBus and communicates with the S800 I/O modules. It is a pure “slave station” on PROFIBUS-DPV1 which is controlled by a master station.

I/O Station modules are mounted on DIN rails and are connected by the ModuleBus. [Figure 5](#) shows the FCI modules mounted on a Module Termination Unit TU847 and connected to the Optical ModuleBus Port TB842. [Figure 6](#) shows the FCI modules mounted on TU846 and connected to the Optical ModuleBus Port TB842.

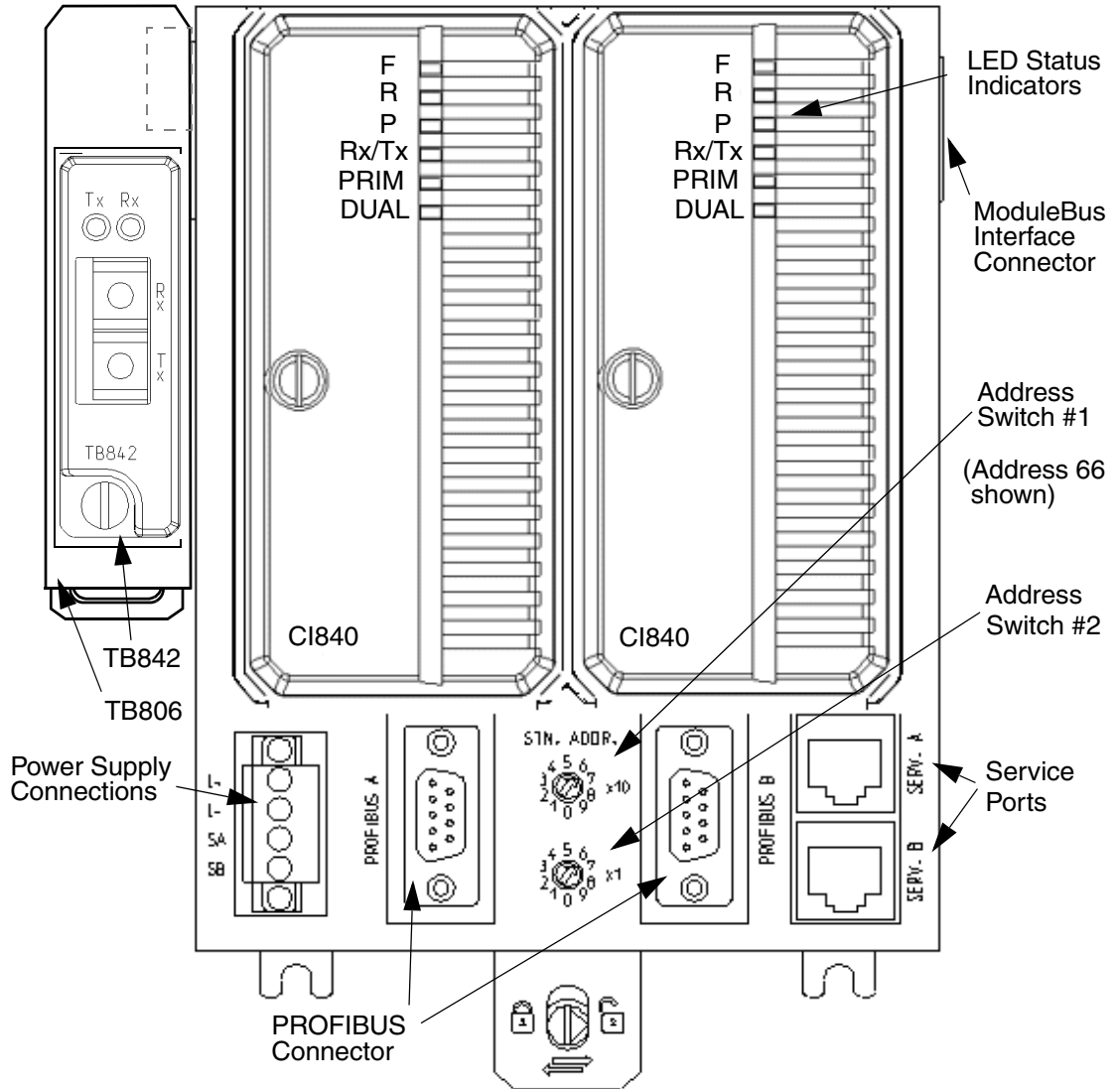

Figure 5. CI840 FCI Module, TU847 Termination Unit and TB842 Optical ModuleBus Port

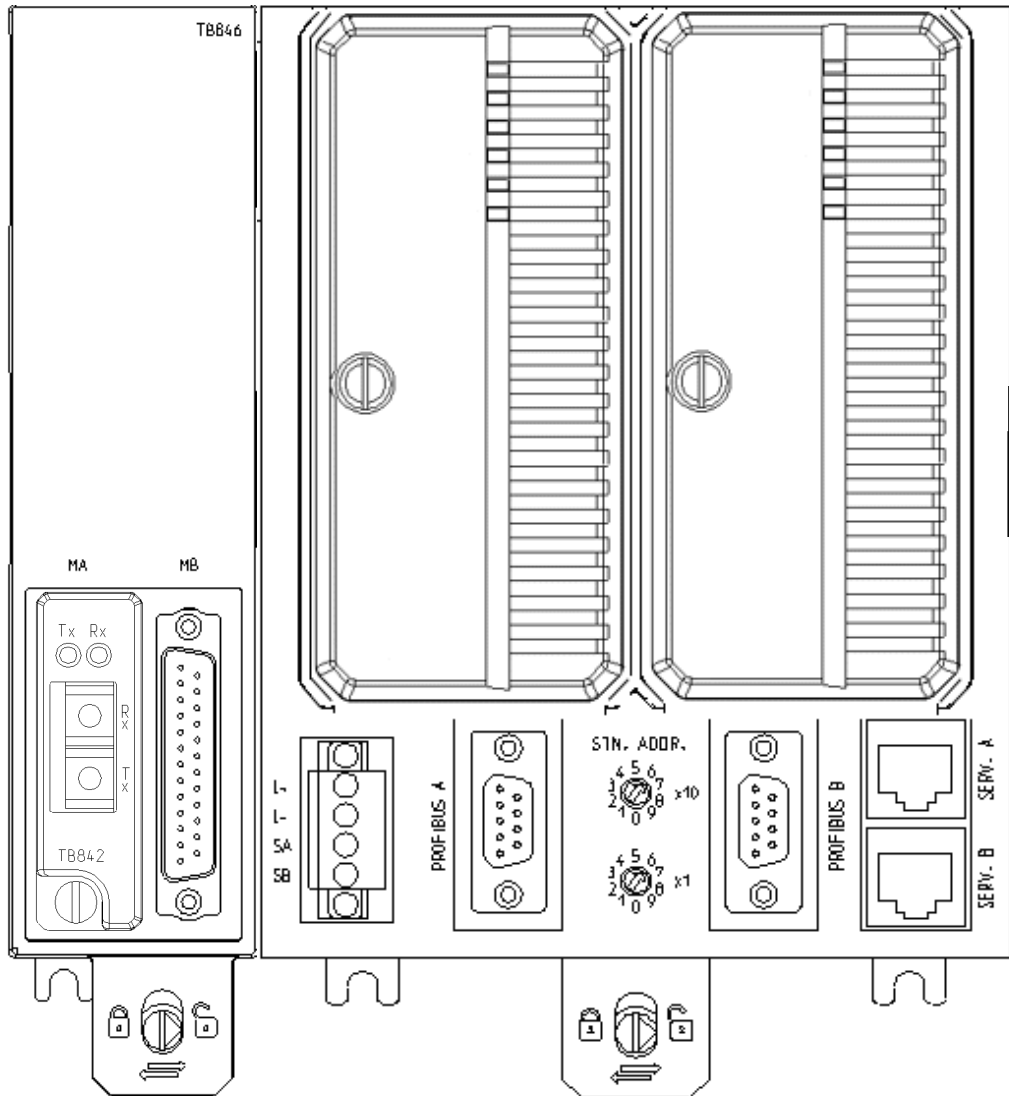

Figure 6. CI840 FCI Module, TU846 Termination Unit and TB842 Optical ModuleBus Port

The FCI communicates with the PROFIBUS Master, ModuleBus Modems and the I/O modules. The FCI handles the I/O-modules operations such as read and write data, read status and configuration of modules and channels. The FCI has a connection to the TB842 Optical ModuleBus Port.

The FCI provides 24 V d.c. (from the source) and an isolated 5 V d.c. power to the base cluster's I/O modules (12 maximum or 6 pairs) by way of the ModuleBus connections. One power source (single or redundant 24 V d.c.) can be connected to the power terminals (L+ & L-) of the MTU.

1:1 redundant power sources can be supervised by connecting the power sources POWER OK status signals to terminals SA and SB.

The size, type and direction of data to be transferred on the PROFIBUS-DPV1 bus depends on and is determined by the I/O module type. The FCI can be configured to send or transmit dynamic data over the PROFIBUS-DPV1 with cycle times in the interval from 1 ms.

For CI840 FCI and TU846/TU847 dimensions, see [Figure 7](#) and [Figure 8](#).

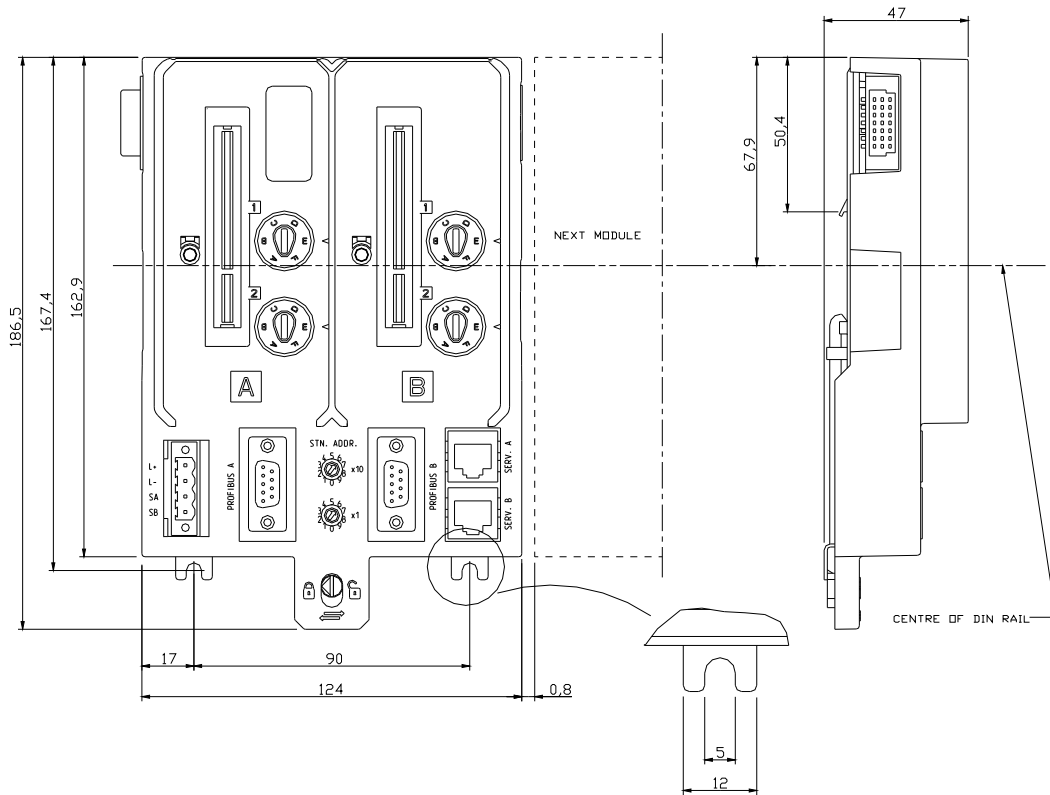

Figure 7. TU847 Dimensions (Same Dimensions for TU846)

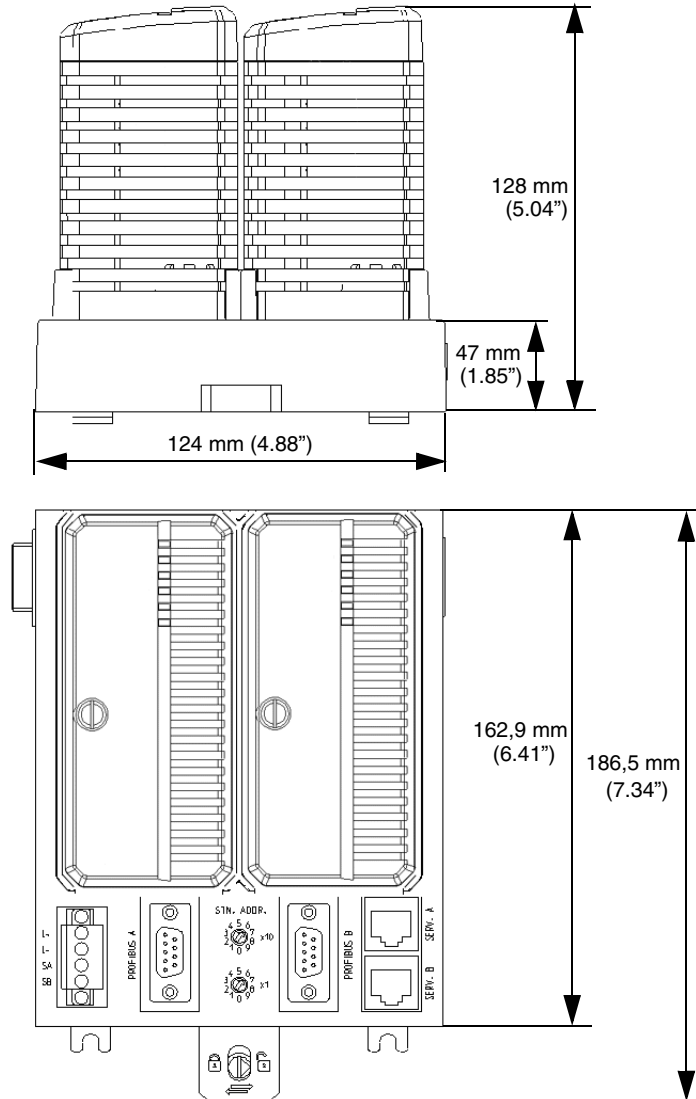

Figure 8. CI840 FCI and TU847 Terminal Unit Dimensions (Same Dimensions for TU846)

Section 2 Installation

Refer *S800 I/O Getting Started (3BSE020923*)*.

For PROFIBUS, see *PROFIBUS DP Wiring and Installation (3BDS009029*)*.

Section 3 Configuration

CI801 FCI

The FCI needs to be connected to the PROFIBUS-DPV1 and have an address selected. It is also connected to a 24 V d.c. power source to provide power to the I/O Station. Also refer to [Configuration and Performance](#) on page 42 for information on how to estimate the fieldbus and power loading of each I/O station configuration.

Address Switches

The CI801 is equipped with two rotary switches used as station address selectors for PROFIBUS connection. The station address can be set in the range of 01 to 99. There can be up to 32 stations per PROFIBUS-DPV1 segment. [Figure 9](#) shows the front panel of the CI801.

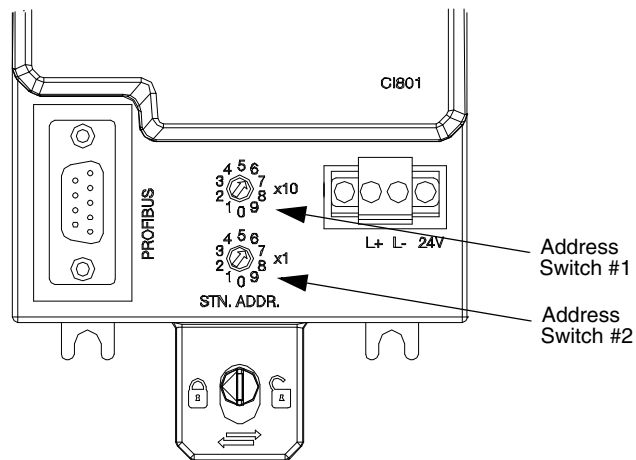

Figure 9. CI801 Front Panel

PROFIBUS Connection

The FCI connects to the PROFIBUS through the 9 pin D-way connector on the front. This allows the FCI (if not the last one at the PROFIBUS segment) to be removed from the PROFIBUS without disconnecting the other nodes of the fieldbus.

If CI801 is the last module at a PROFIBUS segment and supplies an active termination in the cable connector, disconnection of the power supply or the PROFIBUS cable from CI801 can not be done without disrupting the bus.

See [Figure 10](#) for CI801 connection details.

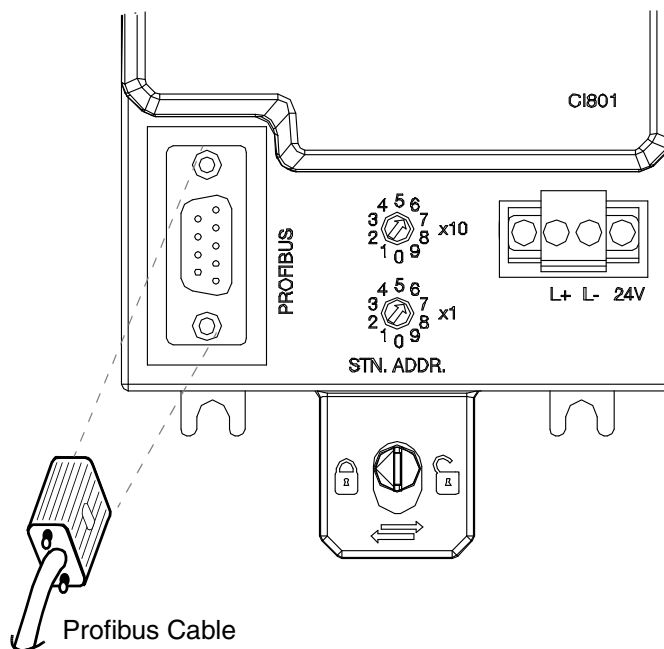

Figure 10. CI801 FCI PROFIBUS Terminal Connections

Table 2 shows the fieldbus connection assignments.

Table 2. FCI PROFIBUS Connections

Pin	Designation	Description
1	Shield	Shield/protective ground
2	-	Not used
3	RxD/TxD-P	Receive/Transmit data - plus
4	RTS	Direction control (optional)
5	DGND	Data ground
6	VP	Supply voltage for the terminating resistors
7	-	Not used
8	RxD/TxD-N	Receive/Transmit data - minus
9	DGND	Data ground (if RTS is used)

Power Supply Connections

The FCI requires 24 V d.c. (19.2 - 30 V) with a maximum current requirement of 2.3 A. See [Table 4](#) for power supply connections.

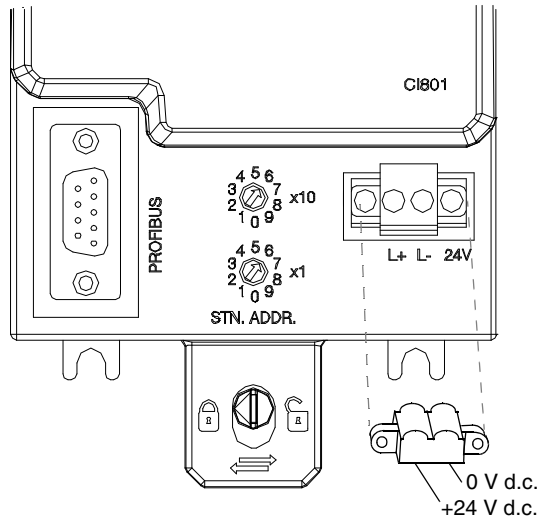

Figure 11. CI801 FCI Power Supply Connections

The incoming power can then be distributed to other FCIs or the I/O modules if desired. Refer to *S800 I/O Getting Started (3BSE020923*)* manual for power supply connection diagrams.

Power connections can accept 0.25 - 2.5 mm² (24 - 14 AWG) wire size.

FCI power supply connections are presented in [Table 3](#):

Table 3. FCI Power Connection Terminal

Pin	Designation	Description
1	L+	+24 V d.c. Supply
2	L-	0 V d.c. Supply

CI830 FCI

The FCI needs to be connected to the PROFIBUS-DP and have an address selected. It is also connected to a 24 V d.c. power source to provide power to the I/O Station. Also refer to [Configuration and Performance](#) on page 42 for information on how to estimate the fieldbus and power loading of each I/O station configuration.

Address Switches

The CI830 is equipped with two rotary switches used as station address selectors for PROFIBUS-DP connection. The station address can be set in the range of 01 to 79. There can be up to 32 stations per PROFIBUS-DP segment. [Figure 12](#) shows the front panel of the CI830.

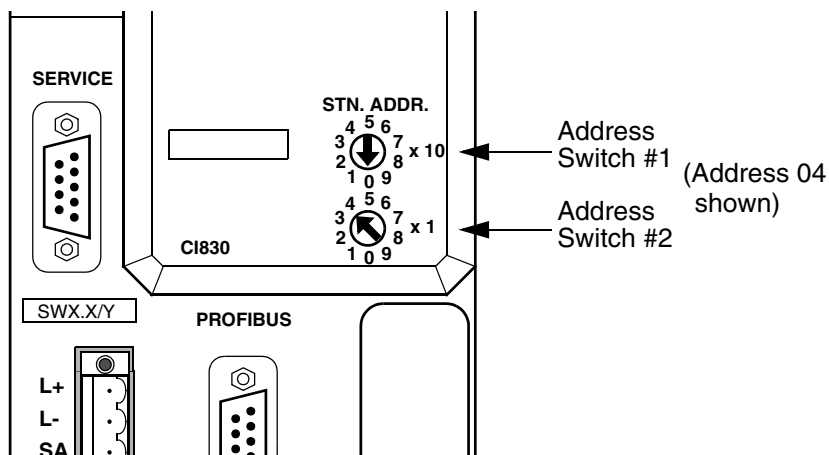

Figure 12. Front Panel of the CI830 FCI

PROFIBUS-DP Connections

The FCI connects to the PROFIBUS-DP via the 9 pin D-way connector on the front. This allows the FCI (if not the last one at the PROFIBUS segment) to be removed from the PROFIBUS-DP without disconnecting the other nodes of the fieldbus. If CI830 is the last module at a PROFIBUS segment and supplies an active termination in the cable connector, disconnection of the power supply or the PROFIBUS cable from CI830 can not be done without disrupting the bus.

See [Figure 13](#) for CI830 connection details.

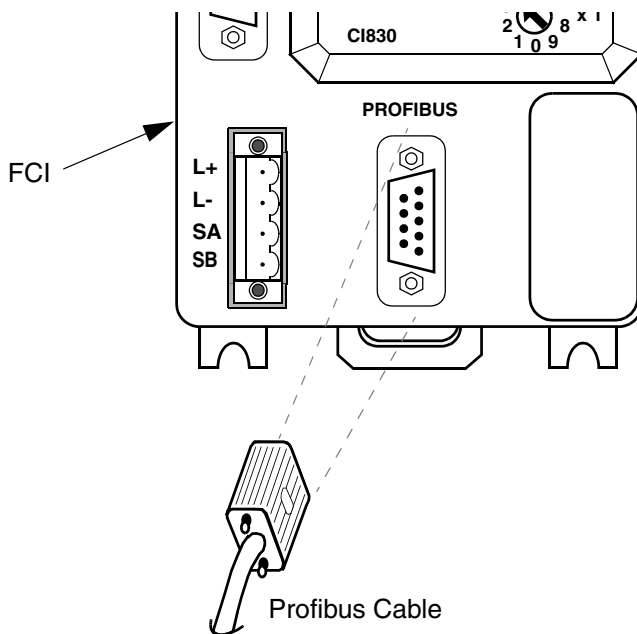

Figure 13. CI830 FCI PROFIBUS Terminal Connections

[Table 4](#) shows the fieldbus connection assignments.

Table 4. FCI PROFIBUS Connections

Pin	Designation	Description
1	Shield	Shield/protective ground
2	-	Not used
3	RxD/TxD-P	Receive/Transmit data - plus
4	-	Not used
5	DGND	Data ground

Table 4. FCI PROFIBUS Connections (Continued)

Pin	Designation	Description
6	VP	Supply voltage for the terminating resistors
7	-	Not used
8	RxD/TxD-N	Receive/Transmit data - minus
9	-	Not used

Power Supply Connections

The FCI requires 24 V d.c. (19.2 - 30 V) with a maximum current requirement of 1.4 Ampere. See [Figure 14](#) for power supply connections.

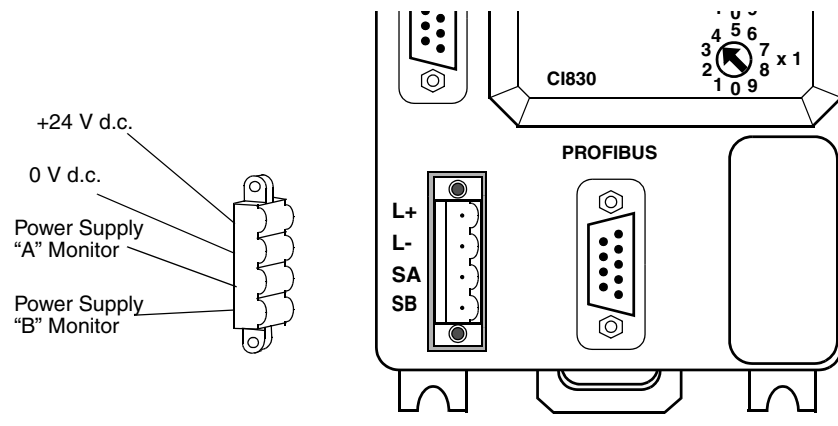

Figure 14. FCI Power Supply Connections

The incoming power can then be distributed to other FCIs or the I/O modules if desired. Refer to S800 I/O Getting Started (3BSE020923*) for power supply connection diagrams.

Power connections can accept 0.25 - 2.5 mm² (24 - 14 AWG) wire size.

FCI power supply connections are presented in [Table 5](#):

Table 5. FCI Power Connection Terminal

Pin	Designation	Description
1	L+	+24 V d.c. Supply
2	L-	0 V d.c. Supply
3	SA	Redundant Power Supply Monitoring Input
4	SB	Redundant Power Supply Monitoring Input

CI840 FCI

The FCI needs to be connected to the PROFIBUS-DPV1 and have an address selected. It is also connected to a 24 V d.c. power source to provide power to the I/O Station. Also refer to [Configuration and Performance](#) on page 42 for information on how to estimate the fieldbus and power loading of each I/O station configuration.

Address Switches

The TU846/TU847 is equipped with two rotary switches used as station address selectors for PROFIBUS-DPV1 connection. 0-62 are allowed for redundant FCI connections and 0-99 are allowed for single connections. The FCI in position B will not start when addresses between 63 and 99 are used. There can be up to 32 stations per PROFIBUS-DPV1 segment. [Figure 15](#) shows the front panel of the TU846/TU847.

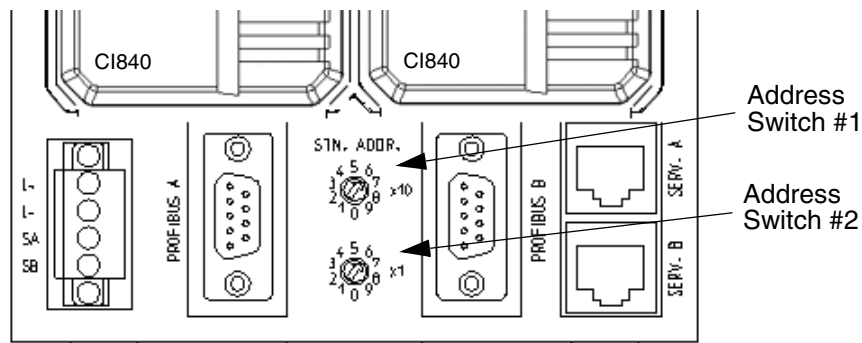

Figure 15. TU846/TU847 Front Panel

PROFIBUS Connections

The FCI connects to the PROFIBUS via the 9 pin D-way connector on the front of TU846/TU847. This allows the FCI (if not the last one at the PROFIBUS segment) to be removed from the PROFIBUS without disconnecting the other nodes of the fieldbus. If CI840 is the last module at a PROFIBUS segment and supplies an active termination in the cable connector, disconnection of the power supply or the PROFIBUS cable from CI840 can not be done without disrupting the bus, nor can the CI840 be removed.

See [Figure 16](#) for CI840 connection details.

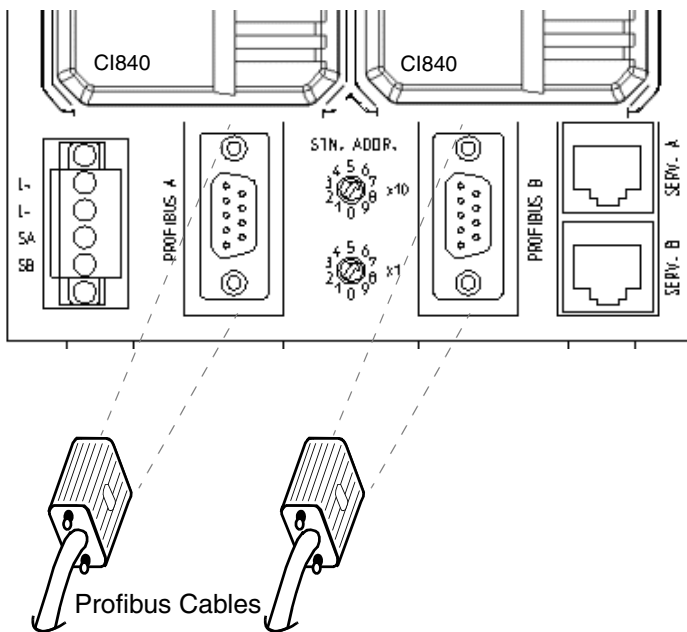

Figure 16. CI840 FCI PROFIBUS Terminal Connections

[Table 6](#) shows the fieldbus connection assignments.

Table 6. FCI PROFIBUS Connections

Pin	Designation	Description
1	Shield	Shield/protective ground
2	-	Not used
3	RxD/TxD-P	Receive/Transmit data - plus
4	RTS	Direction control (optional)
5	DGND	Data ground

Table 6. FCI PROFIBUS Connections (Continued)

Pin	Designation	Description
6	VP	Supply voltage for the terminating resistors
7	-	Not used
8	RxD/TxD-N	Receive/Transmit data - minus
9	DGND	Data ground (if RTS is used)

Power Supply Connections

The FCI requires 24 V d.c. (19.2 - 30 V) with a maximum current requirement of 2.3 A. See Figure 17 for power supply connections.

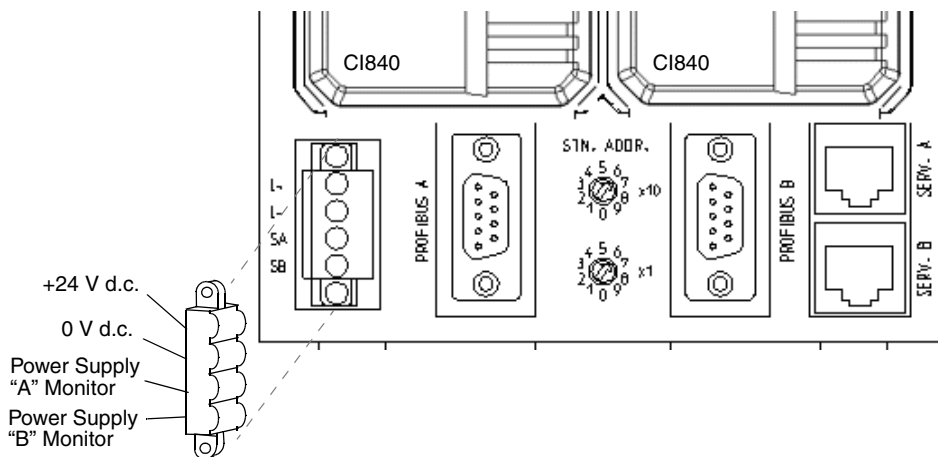

Figure 17. FCI Power Supply Connections

The incoming power can then be distributed to other FCIs or the I/O modules if desired. Refer to *S800 I/O Getting Started (3BSE020923*)* manual for power supply connection diagrams.

Power connections can accept 0.25 - 2.5 mm² (24 - 14 AWG) wire size.

FCI power supply connections are presented in [Table 7](#).

Table 7. FCI Power Connection Terminal

Pin	Designation	Description
1	L+	+24 V d.c. Supply
2	L-	0 V d.c. Supply
3	SA	Redundant Power Supply Monitoring Input
4	SB	Redundant Power Supply Monitoring Input

Configuration and Performance

CI801 Configuration Rules

The maximum number of S800 I/O stations per bus is: 99 stations

Supported communication speeds: 9.6 kbit/s to 12 Mbit/s

The maximum number of S800 I/O stations per bus segment is: 32 stations

The maximum number of I/O modules in a station is: 24 modules

The maximum number of I/O modules per cluster is: 12 modules

It is not allowed to physically install more than 12 MTUs and/or S800L modules in a cluster.

Due to the PROFIBUS-DPV1 specification, it is not possible to always connect 24 I/O modules to one FCI. The reason is that the S800 I/O system includes more data and user parameters than PROFIBUS-DPV1 can handle. [Table 8](#) shows maximum number of I/O modules that can be connected to one CI801.

Table 8. Maximum Number of Modules on CI801

Module Type	Number of Modules
AI801, AI810, AI830, AI830A, AI835, AI835A, AI890, AI893, AI895	14 (11)
AI820, AI825	24 (22)
AI843	11 (9)
AI815, AI845	14 (11)
AO801, AO810, AO810V2, AO890, AO895	7 (5)
AO820	14 (11)
AO815, AO845, AO845A	7 (5)
DI801, DI802, DI803, DI810, DI811, DI820, DI821	24 (24)
DI818	24 (24)
DI828	24 (24)
DI840	16 (16)
DO801, DO810, DO814	22 (21)
DO818	13 (13)
DO802, DO815, DO820, DO821	24 (24)
DO828	22 (21)
DO840	20 (19)
DP820	8 (6)
DP840	7 (5)
Standard Drives	9 (7)

The values in brackets are in Extended HART mode and HCIR.

In order to find out if a given configuration of analog and digital modules can be used the following method should be used:

- Fill in number of modules in [Table 9](#).
- Calculate the sum in the three columns:
 - Sum User Parameters.
 - Sum Input Bytes.
 - Sum Output Bytes.
- Calculate the three total sums for:
 - ParamSize
 - InSize
 - OutSize.
- Check that:
 - ParamSize is less than or equal to 221 (220 if HCIR is used) in normal mode, 218 (217 if HCIR is used) in Extended HART mode.
 - InSize is less than or equal to 239 in normal mode, 199 in Extended HART mode.
 - OutSize is less than or equal to 112 in normal mode, 90 in Extended HART mode.

If any of these three values is too high then the configuration can **not** be used.

Table 9. Calculation of Number of Modules on CI801

Module Type	User Parameters	Input Bytes	Output Bytes	Number of Modules	Sum User Parameters	Sum Input Bytes	Sum Output Bytes
AI801	13	17	0				
AI810	13	17	0				

Table 9. Calculation of Number of Modules on CI801 (Continued)

Module Type	User Parameters	Input Bytes	Output Bytes	Number of Modules	Sum User Parameters	Sum Input Bytes	Sum Output Bytes
AI820	9	9	0				
AI825	9	9	0				
AI830/ AI830A	12	17	0				
AI835	15	17	0				
AI835A	16	17	2				
AI843	16	20	2				
AI815, AI845	13	17	0				
AI890	13	17	0				
AI893	15	17	0				
AI895	13	17	0				
AO801	17	1	16				
AO810/ AO810V2	17	1	16				
AO820	11	1	8				
AO815, AO845/ AO845A	18	1	16				
AO890	17	1	16				
AO895	17	1	16				
DI801	7	4	0				
DI802	6	2	0				

Table 9. Calculation of Number of Modules on CI801 (Continued)

Module Type	User Parameters	Input Bytes	Output Bytes	Number of Modules	Sum User Parameters	Sum Input Bytes	Sum Output Bytes
DI803	6	2	0				
DI810	7	4	0				
DI811	7	4	0				
DI814	7	4	0				
DI818	9	8	0				
DI820	6	2	0				
DI821	6	2	0				
DI828	7	4	0				
DI840	13	4	0				
DI890	7	2	0				
DO801	10	2	2				
DO802	7	1	1				
DO810	10	2	2				
DO814	10	2	2				
DO815	8	1	1				
DO818	16	4	4				
DO820/ DO821	7	1	1				
DO828	10	2	2				
DO840	11	2	2				
DO890	6	1	1				
DP820	12	18	13				

Table 9. Calculation of Number of Modules on CI801 (Continued)

Module Type	User Parameters	Input Bytes	Output Bytes	Number of Modules	Sum User Parameters	Sum Input Bytes	Sum Output Bytes
DP840	10	34	0				
Standard Drives	4	13	12				
Total sum	-	-	-		ParamSize	InSize	OutSize

CI830 Configuration Rules

The maximum number of S800 I/O stations per bus is: 79 stations.
Supported communication speed: 9.6 kbits/s to 12 Mbit/s.

The maximum number of S800 I/O stations per bus segment is: 32 stations.

The maximum number of I/O modules in a station is: 24 modules

The maximum number of I/O modules per cluster is: 12 modules

It is not allowed to physically install more than 12 MTUs and/or S800L modules in a cluster.

Due to the PROFIBUS-DP specification it is not possible to always connect 24 I/O modules to one FCI. The reason is that the S800 I/O system includes more data and user parameters than PROFIBUS-DP can handle. [Table 10](#) shows maximum number of I/O modules that can be connected to one CI830.

Table 10. Maximum Number of Modules on CI830

Module Type	Number of Modules
AI801, AI810, AI830, AI830A, AI835, AI835A, AI890, AI893	12
AI820, AI825	20

Table 10. Maximum Number of Modules on CI830 (Continued)

Module Type	Number of Modules
AO801, AO810, AO810V2, AO890	13
AO820	21
DP820	11
DP840	6
All DI and DO modules	24
ABB Standard Drive	17/24 ⁽¹⁾

(1) See [Table 11](#).

In order to find out if a given configuration of analog and digital modules can be used the following method should be used:

- Fill in number of modules in [Table 11](#).
- Calculate the sum in the three columns:
 - Sum User Parameters.
 - Sum Input Bytes.
 - Sum Output Bytes.
- Calculate the three total sums for:
 - ParamSize.
 - InSize.
 - OutSize.
- Check that:
 - ParamSize is less than or equal to 237.
 - InSize is less than or equal to 244.
 - OutSize is less than or equal to 244.

If any of these three values is too high then the configuration can **not** be used.

- Round up the values **InSize**, **OutSize** and the sum of **ParamSize+15** to the nearest multiple of eight (8), for example, 233 is rounded to 240.
- Finally calculate the memory size with the formula:

$$\text{MemSize} = a + 2 \times \text{RoundParamSize} + 3 \times (\text{RoundInSize} + \text{RoundOutSize}).$$

$$a = 656 \text{ for firmware release 1.0 and 1.1.}$$

$$a = 728 \text{ for firmware release 1.2 or later.}$$



Check that MemSize is less than or equal to 2048. If not, the configuration can **not** be used.

Data with * are valid for CI830 firmware 1.0 to 1.2.

Data inside parenthesis () are valid for CI830 firmware version 1.3 or higher.

Table 11. Calculation of Number of Modules on CI830

Module Type	User Parameters	Input Bytes	Output Bytes	Number of Modules	Sum User Parameters	Sum Input Bytes	Sum Output Bytes
CI830	3	4	0	1	3	4	0
AI801	7	20	4				
AI810	11	20	4				
AI820	7	12	4				
AI825	7	12	4				
AI830/ AI830A	11	20	4				
AI835/AI835A	13	20	4				
AI890	7	20	4				
AI893	13	20	4				
AO801	16	4	18				

Table 11. Calculation of Number of Modules on CI830 (Continued)

Module Type	User Parameters	Input Bytes	Output Bytes	Number of Modules	Sum User Parameters	Sum Input Bytes	Sum Output Bytes
AO810/ AO810V2	16	4	18				
AO820	10	4	10				
AO890	16	4	18				
DI801	4	6	4				
DI802	4	6	2				
DI803	4	6	2				
DI810	4	6	4				
DI811	4	6	4				
DI814	4	6	4				
DI820	4	6	2				
DI821	4	6	2				
DI890	4	6	4				
DO801	8	4	4				
DO802	6	4	4				
DO810	8	4	4				
DO814	8	4	4				
DO815	6	4	4				
DO820/821	6	4	4				
DO890	5	4	4				
DP820	11	22	16				

Table 11. Calculation of Number of Modules on CI830 (Continued)

Module Type	User Parameters	Input Bytes	Output Bytes	Number of Modules	Sum User Parameters	Sum Input Bytes	Sum Output Bytes
DP840	7	36	4				
ABB Standard Drive	3* (4)	14* (8)	12* (6)				
Total sum	-	-	-		ParamSize	InSize	OutSize
Rounded sum	-	-	-		Round ParamSize	Round InSize	Round OutSize

Data with * are valid for CI830 firmware 1.0 to 1.2.

Data inside parenthesis () are valid for CI830 firmware version 1.3 or higher.

CI840 Configuration Rules

The maximum number of S800 I/O stations per bus is:

Redundant CI840: 62 stations

Single CI840: 99 stations

Supported communication speeds: 93.75 kbit/s to 12 Mbit/s

The maximum number of S800 I/O stations per bus segment is:

Communication speed 12Mbit/s: 20 stations

Communication speed ≤ 1.5 Mbit/s or less: 32 stations

The maximum number of I/O modules in a station is: 24 modules

The maximum number of I/O modules per cluster is: 12 modules

The 12 modules per cluster can either be 12 single I/O modules or 6 pairs of redundant I/O modules. Redundant I/O modules can only be mounted on the base cluster. It is not allowed to mix single and redundant I/O modules within a cluster.

It is not allowed to physically install more than 12 single MTUs and/or S800L modules in a single cluster. It is also not allowed to physically install more than 6 redundant MTUs in a redundant cluster.

Due to the PROFIBUS-DPV1 specification it is not possible to always connect 24 I/O modules to one FCI. The reason is that the S800 I/O system includes more data and user parameters than PROFIBUS-DPV1 can handle. [Table 12](#) shows maximum number of I/O modules that can be connected to one CI840.

Table 12. Maximum Number of Modules on CI840

Module Type	Number of Modules
AI801, AI810, AI815, AI830, AI830A, AI835, AI835A, AI890, AI893, AI895	14 (11)
AI820, AI825	24 (22)
AI843	11 (9)
AI845	14 (11)
AO801, AO810, AO815, AO810V2, AO845, AO845A, AO890, AO895	7 (5)
AO820	14 (11)
DI801, DI802, DI803, DI810, DI811, DI820, DI821, DI825⁽¹⁾, DI890	24 (24)
DI818	24 (24)
DI828	24 (24)
DI830⁽¹⁾, DI831⁽¹⁾	15 (15)
DI840	16 (16)
DI885⁽¹⁾	22 (21)

Table 12. Maximum Number of Modules on CI840 (Continued)

Module Type	Number of Modules
DO801, DO810, DO814	22 (21)
DO802, DO815, DO820, DO821	24 (24)
DO818	13 (13)
DO828	22 (21)
DO840	20 (19)
DP820	8 (6)
DP840	7 (5)

(1) Not supported by AC 800M

The values in brackets are in Extended HART mode and HCIR.

In order to find out if a given configuration of analog and digital modules can be used the following method should be used:

- Fill in number of modules in [Table 13](#).
- Calculate the sum in the three columns:
 - Sum User Parameters.
 - Sum Input Bytes.
 - Sum Output Bytes.
- Calculate the three total sums for:
 - ParamSize.
 - InSize.
 - OutSize.
- Check that:
 - ParamSize is less than or equal to 221 (220 if HCIR is used) in normal mode, 218 (217 if HCIR is used) in Extended HART mode.

- InSize is less than or equal to 239 in normal mode, 199 in Extended HART mode.
- OutSize is less than or equal to 112 in normal mode, 90 in Extended HART mode.

If any of these three values is too high then the configuration can **not** be used.

Table 13. Calculation of Number of Modules on CI840

Module Type	User Parameters	Input Bytes	Output Bytes	Number of Modules	Sum User Parameters	Sum Input Bytes	Sum Output Bytes
AI801	13	17	0				
AI810	13	17	0				
AI820	9	9	0				
AI825	9	9	0				
AI830/ AI830A	12	17	0				
AI835	15	17	0				
AI835A	16	17	2				
AI843	16	20	2				
AI845/ AI815	13	17	0				
AI890	13	17	0				
AI893	15	17	0				
AI895	13	17	0				
AO801	17	1	16				
AO810/ AO810V2	17	1	16				
AO820	11	1	8				

Table 13. Calculation of Number of Modules on CI840 (Continued)

Module Type	User Parameters	Input Bytes	Output Bytes	Number of Modules	Sum User Parameters	Sum Input Bytes	Sum Output Bytes
AO815/ AO845/ AO845A	18	1	16				
AO890	17	1	16				
AO895	17	1	16				
DI801	7	4	0				
DI802	6	2	0				
DI803	6	2	0				
DI810	7	4	0				
DI811	7	4	0				
DI814	7	4	0				
DI818	9	8	0				
DI820	6	2	0				
DI821	6	2	0				
DI828	7	4	0				
DI825 ⁽¹⁾	9	2	0				
DI830 ⁽¹⁾	14	4	0				
DI831 ⁽¹⁾	14	4	0				
DI840	13	4	-				
DI885 ⁽¹⁾	10	2	0				
DI890	7	2	0				
DO801	10	2	2				

Table 13. Calculation of Number of Modules on CI840 (Continued)

Module Type	User Parameters	Input Bytes	Output Bytes	Number of Modules	Sum User Parameters	Sum Input Bytes	Sum Output Bytes
DO802	7	1	1				
DO810	10	2	2				
DO814	10	2	2				
DO815	8	1	1				
DO818	16	4	4				
DO820/ DO821	7	1	1				
DO828	10	2	2				
DO840	11	2	2				
DO890	6	1	1				
DP820	12	18	13				
DP840	10	34	0				
Total sum	-	-	-		ParamSize	InSize	OutSize

(1) Not supported by AC 800M

Supported I/O Modules and Drives via PROFIBUS and CI801

The following I/O modules are supported by the PROFIBUS Field Communication Interface module CI801:

- AI801, AI810, AI815, AI820, AI825, AI830, AI830A, AI835, AI835A, AI843, AI845, AI890, AI893, AI895.
- AO801, AO810, AO810V2, AO815, AO820, AO845, AO845A, AO890, AO895.

- DI801, DI802, DI803, DI810, DI811, DI814, DI818, DI820, DI821, DI828, DI840 (SOE handling not supported), DI890.
- DO801, DO802, DO810, DO814, DO815, DO818, DO820, DO821, DO828, DO840, DO890.
- DP820, DP840.
- ABB Standard Drives. Have to be connected via TB820.
 - ACS400 with standard drive
 - ACS600 with standard application
 - ACS800 with standard application
 - ACS600 with crane application
 - ACS800 with crane application
 - ACS600 with pump and fan application (PFC)
 - ACS800 with pump and fan application (PFC)
 - DCS400 with standard drive
 - DCS500 with standard drive
 - DCS600 with crane application

Supported I/O Modules and Drives via PROFIBUS and CI830

The following I/O modules are supported by the PROFIBUS Field Communication Interface module CI830:

- AI801, AI810, AI820, AI825, AI830, AI830A¹, AI835, AI835A², AI890, AI893.
- AO801, AO810, AO810V2, AO820, AO890.
- DI801, DI802, DI803, DI810, DI811, DI814, DI820, DI821, DI890.
- DO801, DO802, DO810, DO814, DO815, DI820, DO821, DO890.
- DP820, DP840.

1. Only with AI830 functionality

2. Only with AI835 functionality

- ABB Standard Drives
 - ACS400 with standard drive
 - ACS600 with standard application
 - ACS800 with standard application
 - ACS600 with crane application
 - ACS800 with crane application
 - ACS600 with pump and fan application (PFC)
 - ACS800 with pump and fan application (PFC)
 - DCS400 with standard drive
 - DCS500 with standard drive
 - DCS600 with crane application

Supported I/O Modules via PROFIBUS and CI840

The following I/O modules are supported by the PROFIBUS Field Communication Interface module CI840:

- AI801, AI810, AI815, AI820, AI825, AI830, AI830A, AI835, AI835A, AI843, AI845, AI890, AI893, AI895.
- AO801, AO810, AO810V2, AO815, AO820, AO845, AO845A, AO890, AO895.
- DI801, DI802, DI803, DI810, DI811, DI814, DI818, DI820, DI821, DI828, DI825¹, DI830¹.
- DI831¹, DI840 (SOE handling not supported), DI885¹, DI890.
- DO801, DO802, DO810, DO814, DO815, DO818, DO820, DO821, DO828, DO840, DO8902.
- DP820, DP840.

1. Not supported by AC 800M

Data Scanning

ModuleBus data is scanned (read or written) cyclically, depending on the I/O module configuration. To calculate the I/O scan cycle time in the FCI do as follows:

Totalize (number of module type x) * (used execution time for type x)
(see [Table 14](#)) if the value is a multiple of 2 add 2 to the value. Otherwise increase the total value to the nearest higher multiple of two (2) to get the I/O scan cycle time.

Table 14. I/O Scan Cycle Time in the FCI

Module Type	Execution Time Used in ms			
	CI801	CI830	CI840	
			Single I/O	Redundant I/O pair
AI801, AI810, AI890, AI895	3.00	3.00	3.00	-
AI820, AI825	1.50	1.50	1.50	-
AI830, AI830A, AI835, AI835A, AI893	0.40	0.40	0.40	-
AI843	0.40	-	0.40	0.80
AI815, AI845	3.00	-	3.00	6.00
AO801, AO810, AO810V2, AO815, AO890, AO895	1.20	1.20	1.20	-
AO820	0.60	0.60	0.60	-
AO845, AO845A	1.20	-	1.20	2.40
DI801, DI802, DI803, DI810, DI811, DI814, DI820, DI821	0.43	0.43	0.50	-
DI818	0.86	-	1.0	-
DI828	0.43	-	0.50	-
DI840	0.43	-	0.50	1.00

Table 14. I/O Scan Cycle Time in the FCI (Continued)

Module Type	Execution Time Used in ms			
	CI801	CI830	CI840	
			Single I/O	Redundant I/O pair
DI890	0.43	0.43	0.50	-
DO801, DO802, DO810, DO814, DO815, DO820, DO821	0.43	0.43	0.50	-
DO818	0.86	-	1.0	-
DO828	0.43	-	0.50	-
DO840	0.43	-	0.50	1.00
DO890	0.43	0.43	0.50	-
DP820	1.72	1.72	2.09	-
DP840	3.00	3.00	3.00	6.00
ABB Engineered drive	-	1.72	-	-
ABB Standard drive	0.71	0.86	-	-
FCI CI801	1.18	-	-	-
FCI CI830 firmware 1.0 to 1.2	-	1.40	-	-
FCI CI830 firmware 1.3 or later	-	2.24	-	-
FCI CI840	-	-	2.10	

Analog modules will be scanned every fourth I/O scan cycle time except for AI830, AI830A, AI835, AI835A, AI843 and AI893 modules which will be scanned every tenth time. DI, DO, DP modules and standard drives will be scanned each I/O scan cycle time.

For example, a station with CI830 with firmware 1.3, two AI810, one AO810/AO810V2, two DI810, two DO820 and one AI830/AI830A will give the following I/O scan cycle time:

2 AI810 => 2*3.00 ms =	6.00 ms
1 AO810/AO810V2 => 1*1.20 ms =	1.20 ms
2 DI810 => 2*0.43 ms =	0.86 ms
2 DO810 => 2*0.43 ms =	0.86 ms
1 AI830/AI830A =>1*0.40 ms =	0.40 ms
1 CI830A => 1*2,24 ms =	2.24 ms

	11.56 ms

11.56 ms is not a multiple of 2, so increase of the value to the nearest multiple of 2 gives 12 ms.

That will give an I/O scan cycle time of 12 ms between the FCI and its I/O modules. This means that the DIs and DOs will be scanned every 12 ms, the AI810s and the AO810/AO810V2 every (4*12 ms) 48ms and the AI830/AI830A every (10*12 ms) 120 ms.



Minimum I/O scan cycle time = 4 ms with firmware 1.0 to 1.2.

Minimum I/O scan cycle time = 6 ms with firmware 1.3 or later.

For example, a station with CI801, two AI810, one AO810/AO810V2, two DI810, two DO820 and one AI830/AI830A will give the following I/O scan cycle time:

2 AI810 => 2*3.00 ms =	6.00 ms
1 AO810/AO810V2 => 1*1.20 ms =	1.20 ms
2 DI810 => 2*0.43 ms =	0.86 ms
2 DO810 => 2*0.43 ms =	0.86 ms
1 AI830/AI830A =>1*0.40 ms =	0.40 ms
1 CI801 => 1*1.18ms =	1.18 ms

	10.50 ms

10.50 ms is not a multiple of 2, so increase of the value to the nearest multiple of 2 gives 12 ms.

That will give an I/O scan cycle time of 12 ms between the FCI and its I/O modules. This means that the DIs and DOs will be scanned every 12 ms,

the AI810s and the AO810/AO810V2 every (4*12 ms) 48 ms and the AI830/AI830A every (10*12 ms) 120 ms.



Minimum I/O scan cycle time = 4 ms

For example, a station with CI840, single or redundant, two AI810, one AO810/AO810V2, two DI810, two redundant pairs of DO840 and one redundant pair of AI845 will give the following I/O scan cycle time:

2 AI810 => 2*3.00 ms =	6.00 ms
1 AO810/AO810V2 => 1*1.20 ms =	1.20 ms
2 DI810 => 2*0.50 ms =	1.00 ms
2 DO840 => 2*1.00 ms =	2.00 ms
1 AI845 => 1*6.00 ms =	6.00 ms
1 CI840 => 1*2.10 ms =	2.10 ms

18.30 ms

18.30 ms is not a multiple of 2, so increase of the value to the nearest multiple of 2 gives 20 ms.

That will give an I/O scan cycle time of 20 ms between the FCI and its I/O modules. This means that the DIs and DOs will be scanned every 20 ms, the AI810s and the AO810/AO810V2 every (4*20 ms) 80 ms and the AI830/AI830A every (10*20 ms) 200 ms.



Minimum I/O scan cycle time = 4 ms

Section 4 Operation

Operating Overview

An I/O station is an autonomous station which normally is not handled by an operator. Of course, it is started and sometimes stopped manually. This is done, however, in specific situations such as the time of installation work and maintenance.

Accordingly, operating instructions are spread out in this manual. See where the specific activity is treated.

For general descriptions, see the beginning of this section. For concrete instructions, see [Section 2, Installation](#) and [Section 5, Maintenance](#).

Getting Started

Functional Description

This section describes the functionality and services that the FCI (Fieldbus Communication Interface) offers for a PROFIBUS Master via PROFIBUS-DP/DPV1. This includes a general description of the data flow on PROFIBUS-DP/DPV1, and how the S800 I/O modules are operated and treated.

The FCI acts as a pure slave station on PROFIBUS-DP/DPV1. The FCI controls all operations of an S800 I/O station. It is the bus-master on the S800 I/O ModuleBus. It does this by handling all communications between the PROFIBUS Master and the S800 I/O modules.

The FCI scans all dynamic input data from the input modules and sends it on PROFIBUS-DP/DPV1, and writes all dynamic output data received from PROFIBUS-DP/DPV1 to the output modules.

The FCI is responsible for:

- Module configuration and supervision.
- Performing signal conditioning on input and output values.
- Dynamic data transfer.

Module Configuration and Supervision

The FCI stores the configuration for all configured I/O Modules in the station.

The FCI will continuously supervise all I/O modules being configured by the PROFIBUS Master. It sends the status of all modules to the PROFIBUS Master via PROFIBUS-DP/DPV1.

When the FCI detects an I/O module without configuration, which it has configuration data for, it will automatically load the parameters to the module. The module is then automatically set into operation by the FCI.

Signal Conditioning

The FCI performs the signal conditioning (for example, linearization and filtering) for the more basic I/O modules. This means that the FCI has to make some computation before moving the value to the module or after reading the value from the module. The type of signal conditioning to perform depends on the module type and its configuration (parameter settings).

Intelligent I/O modules do signal conditioning themselves. In this case the FCI only has to move the value to or from the module. This means less load on the FCI which can be used on other modules or services.

Dynamic Data Transfer

[Figure 18](#) gives an overview of how the exchange of dynamic process data is transferred back and forth between the user application and the actual process.

Dynamic Data Exchange

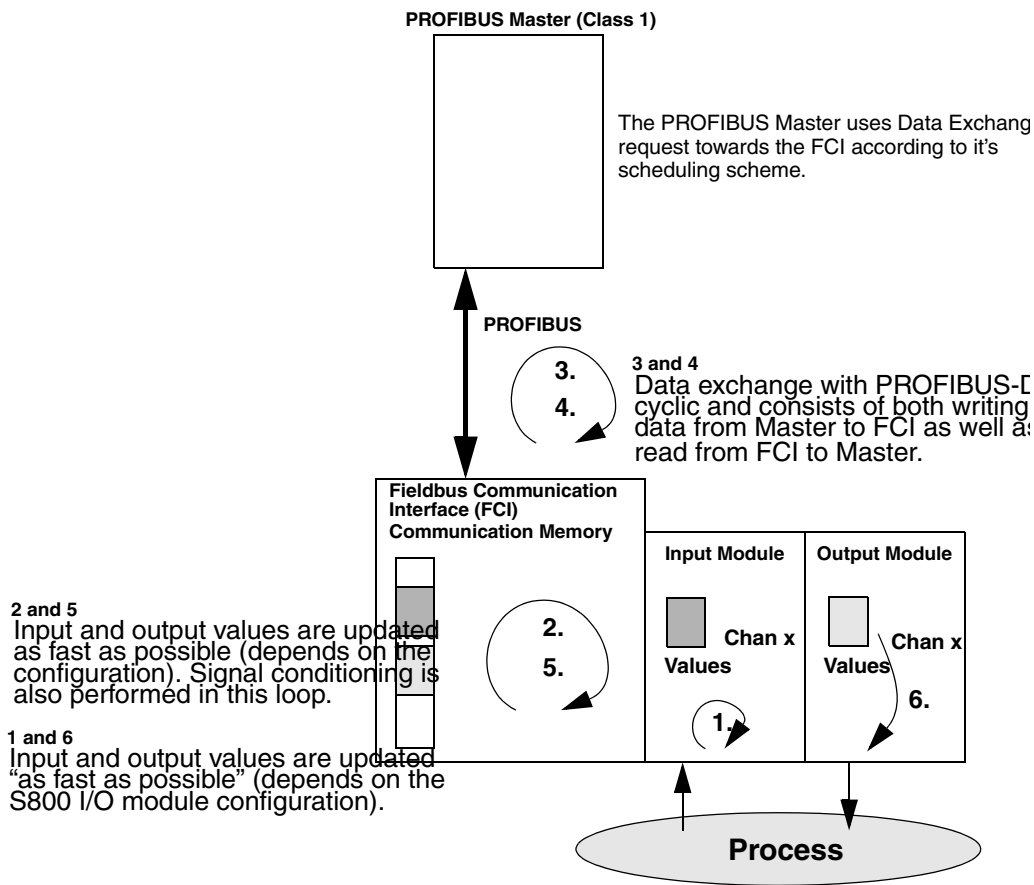

Figure 18. Dynamic Data Exchange for PROFIBUS-DP/DPV1 in Runtime

The transportation of dynamic data between PROFIBUS-DP/DPV1 and the ModuleBus is the main task for the FCI. The FCI has a dedicated memory area where it sends the output values and reads the input values. The CPU in the FCI performs the rest of the data transportation. It reads output values from the memory and writes to the I/O Modules via the ModuleBus and vice versa.

Data Scanning Principles

The data transfer between PROFIBUS-DP/DPV1 and the ModuleBus is not synchronized. Read and write operations are performed from and to a dual port memory in the FCI.

The ModuleBus data is scanned (read or written) cyclically, depending on the I/O module configuration. On one scan all digital modules, 1/4 of the analog modules and 1/10 of the slow analog modules are scanned. It takes 4 scans to read all analog modules and 10 scans to read all slow analog modules.

Redundant FCI

CI840 can work as a redundant pair where one FCI is primary and one is backup. As long as the primary works correct it will handle both the PROFIBUS and the ModuleBus. Both FCIs supervise each other. If a fault occurs in the primary the backup will automatically take over.

Hot Configuration In Run

CI801 and CI840 supports the function Hot Configuration In Run (HCIR).

HCIR is a function for modifying field device configuration without disturbing the running system. The following actions can be done:

- Delete modules
- Insert modules
- Parameter changes

During the configuration the values are frozen for a short moment. The time is dependent of the PROFIBUS master, communication speed, CI801, CI840, type of configuration and type of changes. Typical 300 ms at a communication speed of 1.5 MHz.

The configuration time is supervised by a watchdog. If the watchdog time elapse, the outputs will go to OSP (Output Set as Predefined). The watchdog time consists of two parts, one part calculated by the PROFIBUS master and one fix part for the slave (CI801 and CI840 1200 ms).

HART

The HART communication in CI801 and CI840 is based on Profibus-DPV1 services. The maximum size of the HART frame structure is 64 byte in normal mode and 227 byte in Extended HART mode. For more information see Memory Maps for CI801 (3BSE036959*) or Memory Maps for CI840 (3BSE025251*).

DPV1 Services

For information about Profibus DPV1 services see Memory Maps for CI801 (3BSE036959*) or Memory Maps for CI840 (3BSE025251*).

I/O Module Functionality

All S800 I/O modules have some common functionality. This section describes these common functions of the I/O modules.

An S800 I/O module complies with the following framework:

- General
 - It has a Module Identity (see [Module Identity](#) on page 68).
 - It has a state that can be controlled (see [Module States](#) on page 68).
 - It reports status for modules and channels.
- Parameters
 - It may have configuration parameters for the module and the channels.
 - It may have non-volatile parameters for each channel (factory settings).
- Dynamic values
 - All channels have dynamic values including quality indications.
 - All output channels can be read for verification of the performance and health.

Module Identity

All S800 I/O modules contains a module identity. The module identity is used to verify that an I/O module of the expected (user configured) type is mounted before taking it operational. It protects the system from performing unexpectedly.

Module States

The figure below shows the states of the I/O modules.

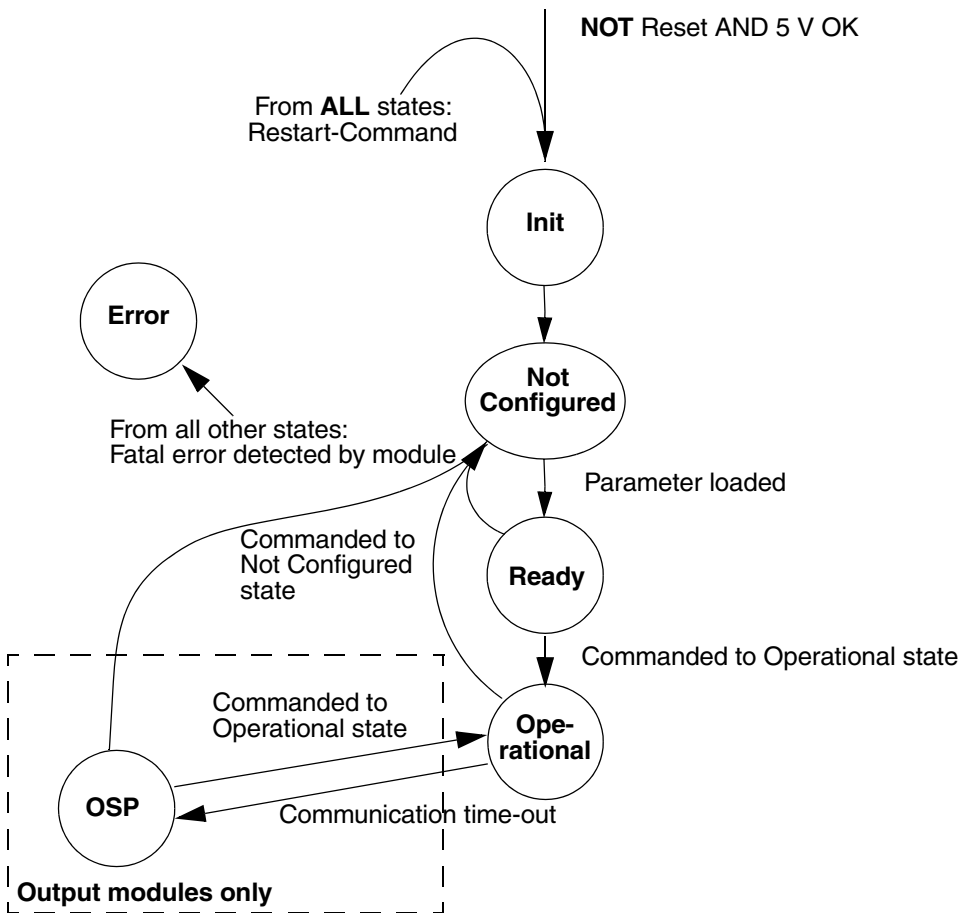

Figure 19. I/O Module States

The states are described in more detail below:

Init State

In the Init state the actual initialization of the module is performed, including a self-test.

Inputs	Not scanned
Outputs	Inactive: 0 V
LEDs	Fault

Not Configured State

In the Not Configured state the module waits to be configured. The FCI performs the parameter download to the module.

Inputs	Not scanned
Outputs	Inactive:0 V
LEDs	Fault until first ModuleBus dialog, then None (and/or Warning if diagnostic warning)

Ready State

Entering the Ready state starts input channel scanning. All active channels are scanned before the state is completely entered. In this state the module just waits to be commanded to the Operational state.

Inputs	Scanned
Outputs	Inactive: 0 V
LEDs	None (or Warning if diagnostic warning)

Operational State

This is the state for normal operation. After entering the Operational state (from Ready or OSP), output channels are still unchanged until a valid output value is written.

Inputs	Scanned
Outputs	Active
LEDs	Run (and Warning if diagnostic warning)

OSP (Outputs Set as Predefined) State

The OSP state is only used by modules with output channels. If OSP is activated it is entered from the Operational state in two cases:

- The supervision time-out on PROFIBUS-DP/DPV1 has elapsed.
- The OSP-watchdog expires, no access has been done to the module within 1024 ms (analog) 256 ms (digital).

See [OSP-Watchdog](#) on page 71.

Entering the OSP state the module sets its outputs to the predetermined values. This means “Keep value” or output the configured OSP value. The outputs are kept unchanged as long as the module stays in the OSP state.

When the PROFIBUS-DP/DPV1 network is operating again the FCI orders the module out of the OSP state.

After re-entering the Operational state, the outputs are still unchanged until valid values are written.

Inputs	Not applicable
Outputs	According to configuration (keep value or OSP value)
LEDs	Run, OSP (and Warning if diagnostic warning)

Error State

This the state that will be entered if a fault is detected.

Inputs	Not scanned
Outputs	Inactive (0 V)
LEDs	Fault

Configuration, Parameters

Configuring an I/O module is equal to writing the parameters to it.

The parameters for a module can mainly be divided into configuration parameters and non-volatile parameters.

Loading Parameters

At start-up, the configuration parameters are loaded by the FCI in the NotConfigured state. When valid configuration parameters are written to the module, it will change from the Not Configured state to the Ready state. After entering the Ready state the module may be set to Operational.

The parameters do not need to be remembered on the modules after a reset of the module since they are saved in the FCI.

Loading Invalid Parameters

If parameters that are in some way invalid are sent to a module, this is indicated with a warning in the module status and by a diagnostic message. If channel parameters are invalid an error on the channel is indicated.

Non-volatile Parameters

Each channel may, apart from the configuration parameters, also have non-volatile parameters that are stored on the module and written during production and are not changed by a running system.

OSP-Watchdog

The OSP-watchdog is a watchdog timer that all I/O modules with output channels have. It supervises the communication to discover if the traffic on the ModuleBus is interrupted. The OSP-watchdog is refreshed when the module is accessed. If this is not done within the time limit the watchdog will force the module to the OSP state (see [Module States](#) on page 68).

The OSP-watchdog is also activated when the PROFIBUS-DP/DPV1 watchdog has elapsed. The supervision time for PROFIBUS-DP/DPV1 is defined in the PROFIBUS configuration tool.



The watchdog on PROFIBUS must be enable to get the OSP function to work on AO and DO modules at communication error on PROFIBUS.

The watchdog time-out should be set to at least four times the PROFIBUS's cycle time.

Section 5 Maintenance

Preventive Maintenance

Refer *S800 I/O Getting Started (3BSE020923*)*.

Hardware Indicators

CI801 FCI Module LEDs

The CI801 FCI has indicators for fault, operational state, power condition, and PROFIBUS communication traffic. [Table 15](#) describes the LEDs, and [Figure 20](#) shows the location of the LEDs on the module.

Table 15. Standard LEDs on CI801 FCI Module

LED	Color	Description
F (Fault)	Red	Fault in the module ⁽¹⁾
R (Run)	Green	Operational state
P (Power ok)	Green	Internal power OK
T (Traffic)	Yellow	Receive transmit data on PROFIBUS

- (1) The F-LED lights up at power up, restart of the module, or when the module goes to Error state. At the start up, the module does a self test; if the self test is OK, the module turns off the F-LED.

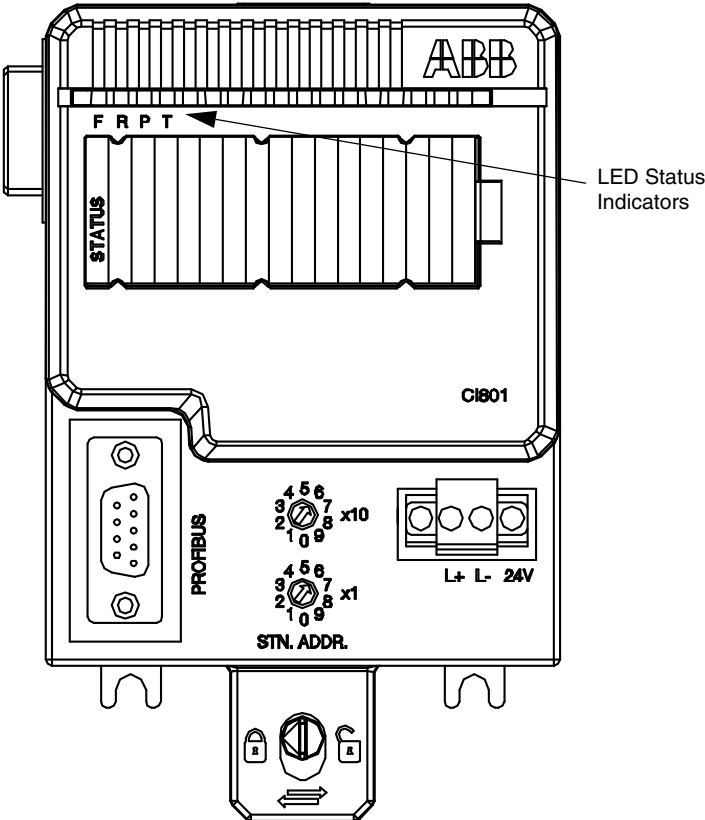

Figure 20. CI801 FCI with Status LEDs Location

CI830 FCI Module LEDs

The CI830 FCI has indicators for fault, operational state, power status, PROFIBUS communication status, and optical ModuleBus communication status. [Table 16](#) describes the LEDs, and [Figure 21](#) shows the location of LEDs on the module.

Table 16. Standard LEDs on CI830 FCI Module with TB810/TB811

LED	Color	Description
F (Fault)	Red	Fault in the module ⁽¹⁾
R (Run)	Green	Operational state
P (Power ok)	Green	Internal power OK
RX (Receive)	Yellow	Receive data on PROFIBUS
TX (Transmit)	Yellow	Transmit data on PROFIBUS
Tx (TB810/TB811)	Yellow	Transmit data on the optical ModuleBus
Rx (TB810/TB811)	Yellow	Receive data on the optical ModuleBus

- (1) The F-LED lights up at power up, restart of the module, or when the module goes to Error state. At the start up, the module does a self test; if the self test is OK, the module turns off the F-LED.

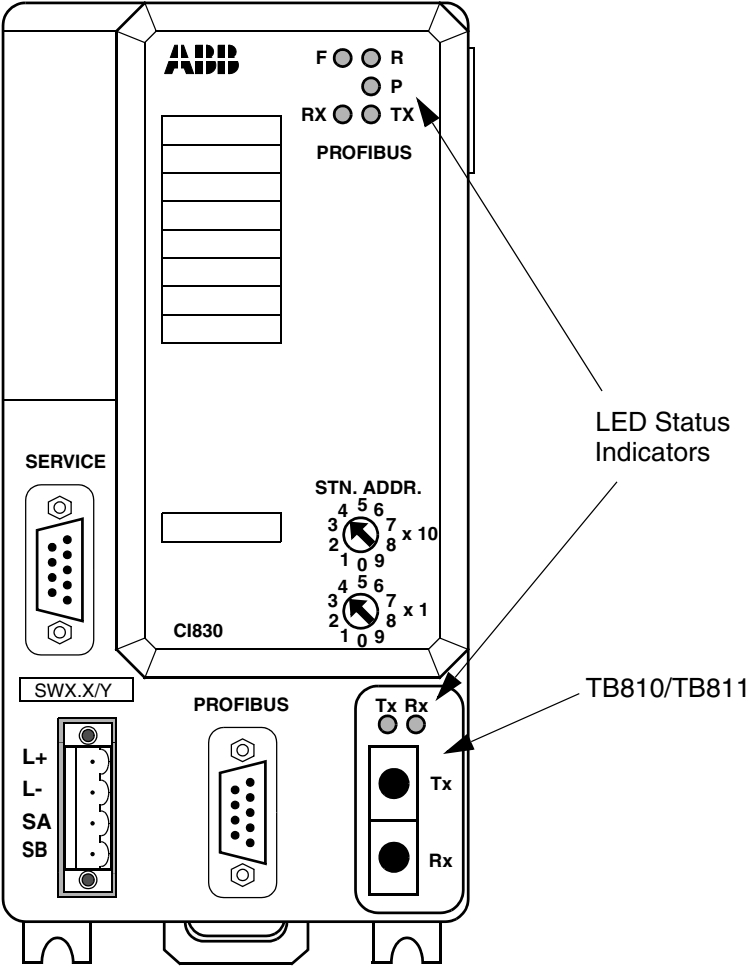

Figure 21. CI830 FCI with TB810/TB811 Status LEDs Location

CI840 FCI Module LEDs

The CI840 FCI has indicators for fault, operational state, power status, PROFIBUS communication state, and for the state in a redundant configuration. [Table 17](#) describes the LEDs, and [Figure 22](#) shows the location of the LEDs on the module.

Table 17. Standard LEDs on CI840 FCI Module

LED	Color	Description
F (Fault)	Red	Fault in the module ⁽¹⁾
R (Run)	Green	Operational state
P (Power ok)	Green	Internal power OK
Rx/Tx (Traffic)	Yellow	Receive transmit data on PROFIBUS
PRIM (Primary)	Yellow	Working as Primary
DUAL	Yellow	Working with a partner

- (1) The F-LED lights up at power up, restart of the module, or when the module goes to Error state. At the start up, the module does a self test; if the self test is OK, the module turns off the F-LED.

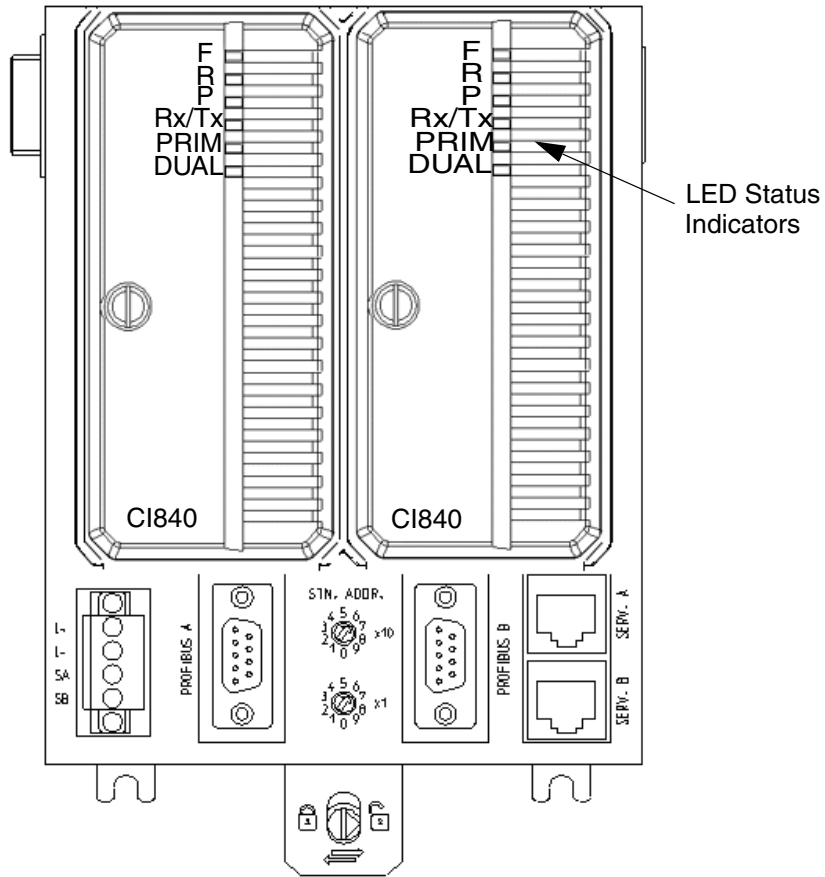

Figure 22. CI840 FCI with Status LEDs Location

Error Messages

Please see the relevant PROFIBUS Master documentation.

Fault Finding and Repair

Communication Module Replacement

General

Communication modules CI801, CI830, and TB820 cannot be replaced online.

Communication modules CI840 and TB840 can be replaced online.

The following notes are applicable to replacement of modules, and its effect on the process:

- Replacement of a communication module type CI801 and CI830 affects all channels on all the modules in an I/O station. The station will lose power.
- Replacement of a communication module type CI840 in a redundant configuration does not affect any channel in an I/O station.
- Replacement of an optical port type TB810/TB811/TB842 affects all channels on all the modules in all clusters, except cluster 0. The communication to all clusters is broken, except for cluster 0.
- Replacement of an optical modem type TB820, or TB840 in a single configuration, connected through a simplex optical cable, affects all channels on all the modules in all clusters except cluster 0. The communication to all clusters is broken, except for cluster 0.
The cluster where the TB820 should be replaced will be powerless.
- Replacement of an optical modem type TB820 or TB840, in a single configuration, connected through a duplex optical cable, affects all channels on all the modules in the cluster and also in all clusters that are located after the cluster where the replaced TB820 or TB840 is located.
The communication to all clusters located after the cluster where the replaced TB820 or TB840 is located, will be broken. The cluster where TB820 or TB840 should be replaced will be powerless.
- Replacement of a communication module type TB840 in a redundant configuration does not affect the channels in an I/O station.

The following topics contain general instructions for replacement of modules, and [Table 18](#) provides additional information on the handling of individual modules.

Practical Execution

Before replacing the modules:

1. Read the *S800 I/O Getting Started (3BSE020923*)* manual.
2. As special restrictions apply to each module type, see the descriptions in [Table 18](#) for useful information on individual module types.
3. Check whether the new module, CI801/CI830/CI840, can be a suitable replacement, and check the software version. If the wrong software version is found, load the new software (see [Backup/Restore Procedures](#) on page 84).



For replacing CI840, perform only the steps 3, 5 and 8, in the procedure described below.

To replace faulty communication modules:

1. Disconnect the power supply/supplies from the module.
2. Disconnect the PROFIBUS and ModuleBus from the module.
3. Extract the module.
4. Set the current Station address or Cluster address on the new module.
5. Insert the new module carefully.
6. Connect the PROFIBUS and ModuleBus to the module.
7. Connect the power supply/supplies to the module.
8. Store extracted modules in protective envelopes.

The modules are initialized automatically by the system, and it takes approximately 60 seconds for a CI801/CI830/CI840 to start up.

Additional Information on Individual S800 Communications Modules

[Table 18](#) provides additional information for replacement of S800 I/O modules.

Table 18. Replacement of S800 I/O Modules







Module Type - Settings	Comments
<p>Switch setting for PROFIBUS address</p>  <p>CI801 FCI</p>	<p>Cannot be replaced with power applied.</p> <p>Needs space to the left in order to be removed.</p> <p>In normal operation mode, before a CI801 is replaced, the supply to the S800 I/O is to be switched off. Power connections can be removed by pulling the header terminals out of the unit.</p> <p>Optical ModuleBus Port TB842 can not be removed with power applied.</p> <p>If a TB842 connected to a CI801 shall be changed in a running system, TB806 has to be disconnected from the FCI first.</p> <p>The fuse for ModuleBus 24 V can be changed if the top cover of the module is removed. For fuse type, see CI801 Technical Data.</p> <p>Fieldbus connections can be removed by pulling the D-way connector out of the unit.</p> <p> If the last CI801 on a PROFIBUS segment supplies an active termination in the cable connector, disconnection of the power supply or the PROFIBUS cable to CI801 cannot be done without disrupting the bus.</p>

Table 18. Replacement of S800 I/O Modules

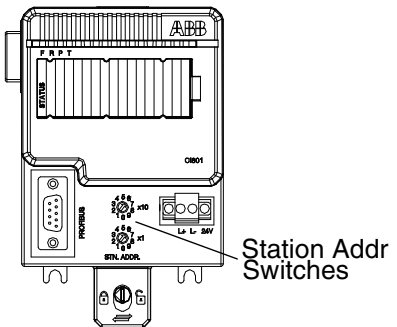
Module Type - Settings	Comments
<p data-bbox="207 346 553 406">Switch setting for PROFIBUS address</p> <div data-bbox="102 570 176 630" style="display: inline-block; vertical-align: middle;"> <p>CI830 FCI</p> </div>  <p data-bbox="445 599 602 645">Station Address Switches</p>	<p data-bbox="655 346 1128 377">Cannot be replaced with power applied.</p> <p data-bbox="655 386 1209 416">Needs space to the left in order to be removed.</p> <p data-bbox="655 427 1232 548">In normal operation mode, before a CI830 is replaced, the supply to the S800 I/O is to be switched off. Power connections can be removed by pulling the header terminals out of the unit.</p> <p data-bbox="655 558 1232 620">Optical ModuleBus Port TB810/TB811 cannot be removed with power applied.</p> <p data-bbox="655 630 1222 691">Fieldbus connections can be removed by pulling the D-way connector out of the unit.</p> <div data-bbox="666 707 729 770" style="display: inline-block; vertical-align: middle;">  </div> <p data-bbox="753 701 1254 859">If the last CI830 on a PROFIBUS segment supplies an active termination in the cable connector, disconnection of the power supply or the PROFIBUS cable to CI830 can not be done without disrupting the bus.</p>
<div data-bbox="102 1065 186 1125" style="display: inline-block; vertical-align: middle;"> <p>CI840/ TB840</p> </div>  <p data-bbox="470 1082 634 1128">Cluster Address Switches</p>	<p data-bbox="655 879 1086 910">Can be replaced with power applied.</p> <p data-bbox="655 920 1240 1012">In redundant configuration, one CI840/TB840 can be replaced without any affects on channel in an I/O station.</p> <p data-bbox="655 1023 1251 1115">If a TB842 connected to a TU846/TU847 shall be changed in a running system, TB806/TB846 has to be disconnected from TU846/TU847 first.</p> <div data-bbox="666 1130 729 1193" style="display: inline-block; vertical-align: middle;">  </div> <p data-bbox="753 1125 1251 1316">If the last CI840 on a PROFIBUS segment supplies an active termination in the cable connector, disconnection of the power supply or the PROFIBUS cable to CI840 cannot be done without disrupting the bus. Also, CI840 cannot be removed.</p>
<p data-bbox="102 1337 193 1397">TU846/ TU847</p>	<p data-bbox="655 1337 1209 1368">Needs space to the left in order to be removed.</p> <p data-bbox="655 1368 1121 1398">Cannot be replaced with power applied.</p>

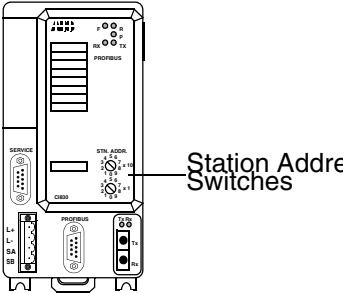
Application Memory Reset

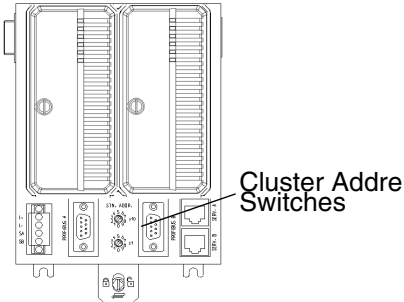
A CI830 can keep an application in memory for a long time, even with the power supply disconnected. To avoid a problem with an FCI that may have an old application, the application memory should be cleared.

To clear the application memory in CI830:

1. Set the address switches to 99.
2. Remove the power supply for a short moment.
3. Apply power and allow the FCI to restart. Wait for 45 seconds. This clears the application memory.
4. Set the address switches to the desired station address.
5. Remove the power supply for a short moment.
6. Apply power and allow the FCI to restart. Wait for 45 seconds. This makes the module ready for the new application.

CI801 Firmware version

It is possible to read the firmware version from the service port (PROFIBUS connection), at startup.

To read the firmware version:

1. Connect a PC to the service port of the CI801 via the service adapter (FS801 and TK802) and cable TK212/TK212A, see [Figure 23](#).
2. Start a terminal program in the PC (for example, Hyperterminal).
3. Set the communication parameters to 9600 bps, 8 bits word length, no parity, 1 bit stop.
4. Set the station address to 0.
5. Disconnect power to the CI801, and connect the power again. The LEDs, F and P, light up.
6. When the CI801 has started up (F LED is off after about 30 seconds), it writes a text string on the terminal program, containing the version number (for example, CI801 SW 1.0/0).

CI840 Firmware version

From CI840 firmware version 3.0/0 and later, it is possible to read its firmware version from the service port, at startup.

In a redundant pair, the firmware version can be read from the backup module. A change over from primary state to backup state can be done by the DTM or by disconnecting the PROFIBUS cable on the primary.

To read the firmware version:

1. Connect the PC to the CI840 (TU846/TU847), using a TK212/TK212A cable between the RS232 service port A or B on the TU846/TU847 (CI840) and the COM1 or COM2 on the PC.
2. Start a terminal program in the PC (for example, Hyperterminal).
3. Set the communication parameters to 9600 bps, 8 bits word length, no parity, 1 bit stop.
4. Disconnect the power to the CI840, and connect the power again by unlocking the screw and locking it again.
5. When the CI840 has started up (after about 30 seconds), it writes a text string on the terminal program, containing the version number (for example, CI840 SW 3.0/0).

Backup/Restore Procedures

Load the CI801 Software Upgrade

Hardware Requirements

- PC with WINDOWS NT 4 or later.
- Service adapter (FS801 + cable TK802) 3BSE038407R1
- Connection cable TK212 3BSC630167R2 or TK212A 3BSC630197R1

Physical Connections

Connect the PC to the CI801, using a TK212/TK212A cable and the service adapter (FS801+TK802) connected between the service port (PROFIBUS connection) on CI801 and the COM1 or COM2 on the PC. Set the station address on CI801 to 0.

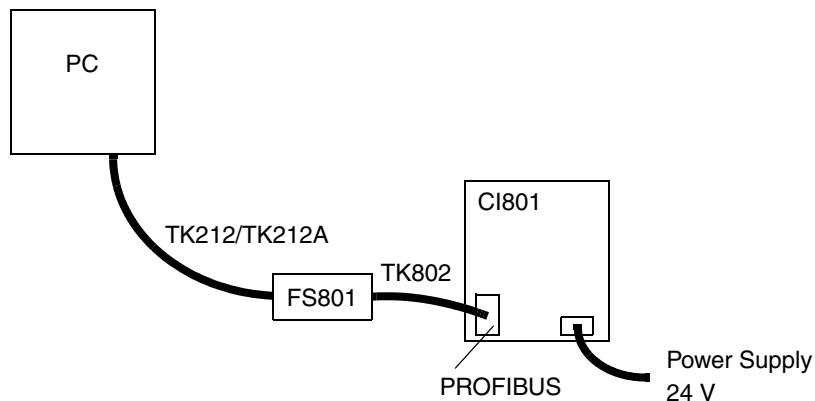

Figure 23. CI801 Connection

Load of firmware

There are two different upgrade instructions for the CI801, depending on its Product Revision (PR:x).

Loading the BASE Firmware for CI801 PR:F or later and CI801ZPR:B or later

The loading of the new firmware takes 3 to 4 minutes.

The following messages are displayed during the download:

- Initialization of target
- Load image file
- Download finished successful

To load the firmware:

1. Run the program, **loader32_42-1.exe**.
2. Click **Next**.
3. Select the COM-Port to use, and enter the path to the image file.
4. Click **Download**.
5. When the download is finished, set the station address back to the used address.
6. Switch off the power supply and then switch on the power supply, to restart CI801.

Loading the BASE Firmware for CI801 PR: A to E and CI801Z PR: A

The loading of the new firmware takes about 15 minutes.

The following messages are displayed during the download:

- Initialization of target
- Load image file
- Download finished successful

To load the firmware:

1. Run the program, **loader32_42-1.exe**.
2. Click **Next**.
3. Select the COM-Port to use, and enter the path to the image file.
4. Disconnect power to CI801 and connect the power again.
5. Wait for the FCI to start up, and then click **Download**.
6. When the download is finished, set the station address back to the used address.
7. Switch off the power supply and then switch on the power supply, to restart CI801.

Troubleshooting

Problem: The cable is disconnected during download, or the power went down.

Solution: Restart CI801 by switching the power OFF and then switching the power ON.

Labelling

Update the firmware version on the firmware label.

Connection cable

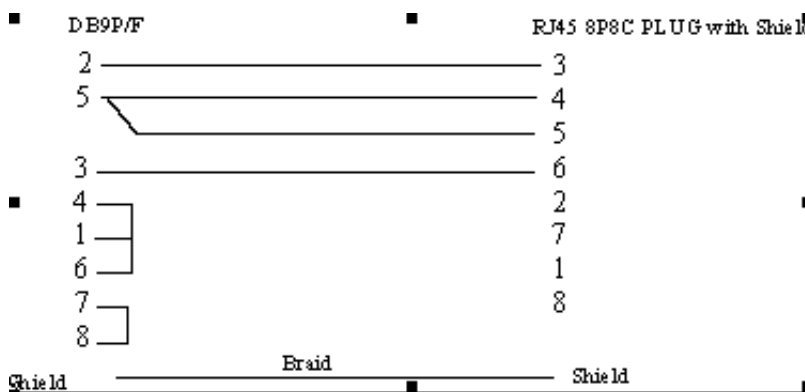

Figure 24. Cable TK212A 3BSC63197R1

Load the CI830 Software Upgrade

Hardware Requirements

- PC with WINDOWS NT 4 or 2000.
- Connection cable TK527 (3BSC950004R1).

It is assumed that the PC communication port is COM1, and the diskette drive is A.

Reset the CI830 application memory. See [Application Memory Reset](#) on page 83.

Connection

Connect the PC and the CI830, using a TK527 (3BSC950004R1) cable between the RS232 service port on the CI830 and the COM1 or COM2 on the PC.

Loading the BASE Software

1. Run the program, **loader32.exe**.
2. Click **Next**.
3. Choose the setting **User defined: Select COM-Port and speed manually**.
4. Click **Next**.
5. Select the COM-Port to use, and enter the path to the image file.
6. Check the **Disable optimization of speed (Fix to 9600 BD)** checkbox, and uncheck the remaining check boxes.
7. Click **Download**.

The loading of the new firmware takes approximately 5 minutes.

Troubleshooting

Problem: The cable is disconnected during download, or the power supply goes off.

Solution: Restart the CI830 by switching power OFF and then switching the power ON.

Labelling

Put the largest label on the back of the CI830 and the smaller one on the front of CI830. See [Figure 25](#).

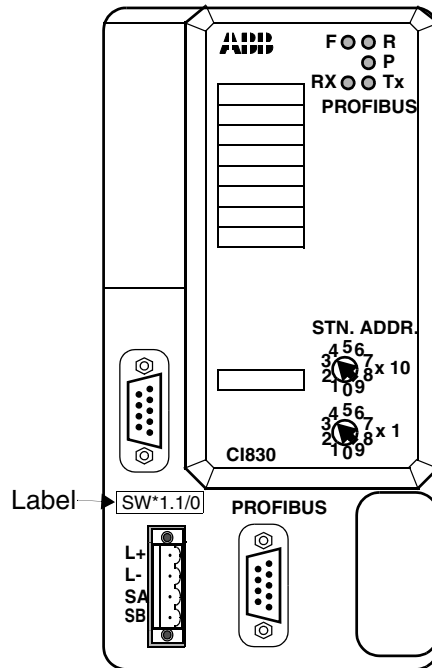

Figure 25. CI830 Software Label Location

Load the CI840 Software Upgrade

Hardware Requirements for CI840/CI840A rev. XX

- PC with Windows NT4 or later
- Connection cable TK212 3BSC630167R2 or TK212A 3BSC630197R1

Connection

Connect the PC and the CI840 (TU846/TU847), using a TK212/TK212A cable between the RS232 service port A or B on the TU846/TU847 (CI840) and the COM1 or COM2 on the PC.

Loading the Firmware

There are two different upgrade instructions for the CI840A and CI840AZ, depending on its Product Revision (PR: *x*).

Loading the Firmware for CI840A PR: B or later and CI840AZ PR: B or later

The loading of firmware takes 3 to 4 minutes with `loader32 4.2/1`

The following messages are displayed during download:

- Initialization of target
- Load image file
- Download finished successful

Loading the Firmware on Single FCI

1. Run the program `loader32_42-1.exe`.
2. Click **Next**.
3. Select COM-Port to use, and enter the path to the image-file.
4. Click **Download**.
5. When the Initialization of target state is displayed, restart the CI840 by unlocking the screw and locking it again before the progress bar reaches 50%.
6. When the download is finished, the CI840 starts up automatically.

Loading the Firmware on Backup FCI when the Primary FCI is running

Follow the same instructions as for Single FCI.

Loading the Firmware in the Primary FCI when the Backup is Running

1. Perform a switch-over to put the Primary FCI in backup state. It can be done by using the DTM or disconnecting the PROFIBUS cable on the primary FCI.
2. Follow the same instructions as for Single FCI.

Loading the Firmware for CI840A PR: A, CI840AZ PR: A, and CI840

There is a small difference between upgrade of a CI840 with firmware 3.0/2 or earlier, and 3.1/0 or later.

The loading of firmware takes approximately 15 minutes.

The following messages are displayed during down load:

- Initialization of target
- Load image file
- Down load finished successful

Loading the Firmware for Single FCI

1. Disconnect the PROFIBUS cable from the module that should be loaded.
2. Run the program `loader32_42-1.exe`.
3. Click **Next**.
4. Select COM-Port to use, and enter the path to the image-file.
5. Click **Download**, and continue with Step6 or Step9.

CI840 with firmware 3.0/2 or earlier

6. Interrupt the downloading by disconnecting the power to the CI840, wait for 20 seconds, and connect the power again.
7. Click **Download**.
8. When the download is finished, the CI840 starts up automatically.

CI840 with firmware 3.1/0 or later.

9. When the download is finished, the CI840 flashes all the LEDs for 1 second, and then turn on the red F(ault) LED.

10. Disconnect power to CI840 and connect the power again, for start up of CI840.

Loading the Firmware on Backup FCI when the Primary FCI is Running

CI840 with firmware 3.0/2 or earlier

11. Follow the instructions as for Single FCI, until Step 5.
The red F(ault) LED lights up.
12. Disconnect the power supply from the backup FCI by unlocking the screw, wait for 20 seconds, and lock it again.
13. Continue the procedure according to Single FCI from Step 7 without any waiting.
14. If the downloading does not start, repeat Step 12 and Step 13.
15. When the download is finished, the CI840 starts up automatically.

CI840 with firmware 3.1/0 or later.

16. Follow the instructions according to Single FCI until Step 5.
The red F(ault) LED lights up.
17. Disconnect the power supply from the backup FCI by unlocking the screw and locking it again.
18. Click **Download**.
19. If the downloading does not start, repeat Step 17 and Step 18.
20. When the download is finished, the CI840 starts up automatically.

Loading the firmware in the Primary FCI when the Backup is Running

21. Do a change over, so that the FCI that should be updated is in backup state.
This can be done by the DTM or by disconnecting the PROFIBUS cable on the primary.
22. Load the firmware as in the topic *Backup FCI when the Primary FCI is running*.

Troubleshooting

Problem: Cable is disconnected during download or the power supply goes off.

Solution: Restart the CI840 by switching the power OFF and switching the power ON again.

Labelling

Update the firmware version on the firmware label.

Connection Cable

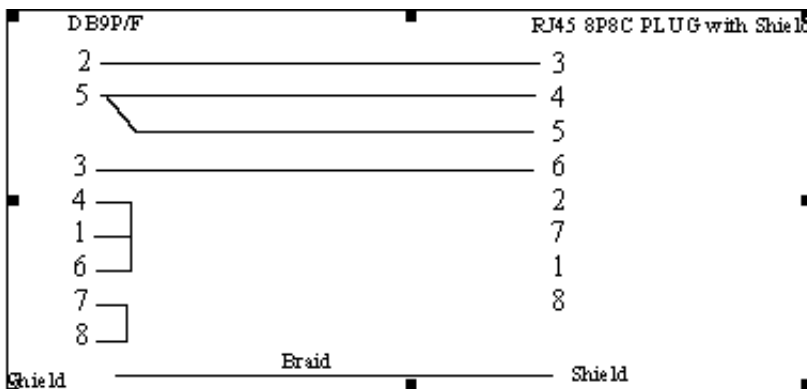

Figure 26. Cable TK212A 3BSC63197R1

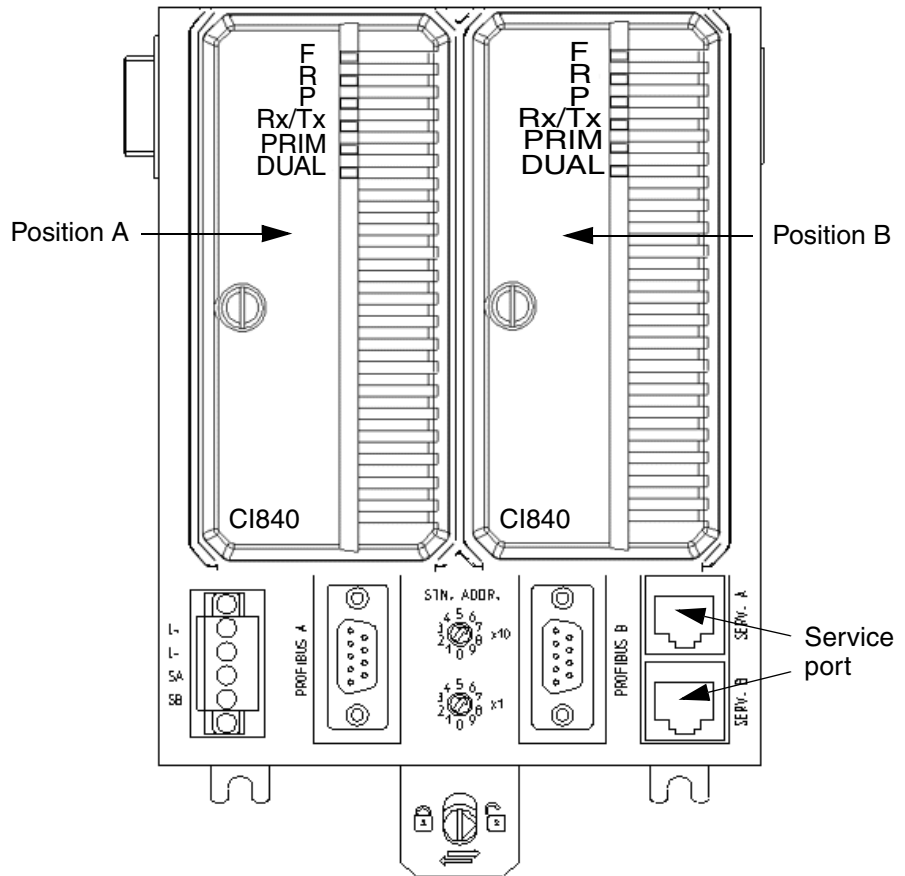

Figure 27. CI840 and TU847

Appendix A Specifications

CI801 Fieldbus Communications Interface (FCI)

Features

- PROFIBUS-DPV1 fieldbus interface.
- Supervisory functions of I/O ModuleBus.
- Isolated power supply to I/O modules.
- OSP handling and configuration.
- Input power fused.
- Hot Configuration In Run.
- HART pass-through.

Description

The CI801 Fieldbus Communications Interface (FCI) is an intelligent communication interface between a Controller via the PROFIBUS-DPV1 fieldbus and the S800 I/O modules via the ModuleBus.

CI801 contains one PROFIBUS-DPV1 interface, electrical ModuleBus interfaces, LED indicators and a service port.

The Profibus connector is also used for service.

Two rotary switches for station address 0-99 settings (0 is used for service).

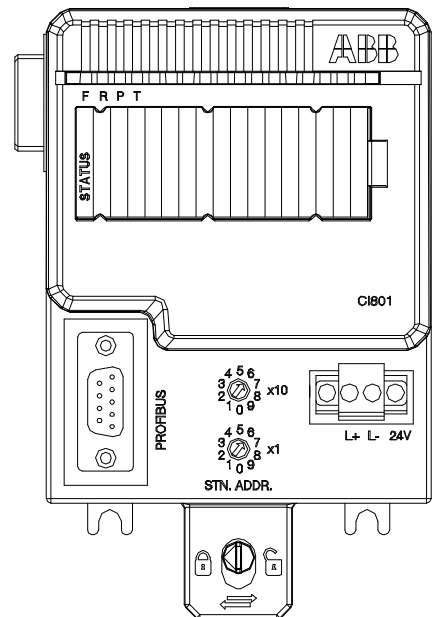

CI801 has isolated power converters that generates internal power for CI801 and current limited +5 V supply for electrical ModuleBuses.

Besides +5 V CI801 also distribute a fused 24 V for the ModuleBus.

The module is DIN-rail mounted and grounded to the DIN-rail. The module detachable screw terminals for power supply D-way terminals for PROFIBUS, one connector for the Optical ModuleBus Port TB842, mounted on TB806, and one electrical ModuleBus.

Technical Data

Table 19. CI801 FCI Specification

Item	Description
Microprocessor (CPU)	Motorola MCF5307 with a speed of 64 MHz
Flash PROM	1 Mbyte
Fast RAM	8 Mbyte
Power Input	24 V d.c. (19.2 - 30)
Power Input Fuse	2 AF
Power Consumption at 24 V d.c.	140 mA
Power Dissipation	5.4 W
Maximum Ambient Temperature	55°C (131°F) horizontal mounted 40°C (104°F) vertical mounted
PROFIBUS (D-sub 9-pole female socket), also used as Service Port	Opto-isolated (RS-485); 12 Mbit/s maximum
ModuleBus	Maximum of 12 I/O modules
Power Output - ModuleBus	24 V max. = 1.5 A fused ⁽¹⁾ 5 V max. = 1.5 A current limited

Table 19. CI801 FCI Specification (Continued)

Item	Description
Safety classification	Class I according to IEC 536; (earth protected)
Protection rating	IP20 according to IEC 529, (IEC 144)
Rated insulation voltage	50 V
Dielectric test voltage	500 V a.c.
Width	86.1 mm (3.39")
Acceptable wire sizes	0.25 - 2.5mm ² , 24 - 14 AWG Recommended torque: 0.5 - 0.6 Nm Stripping length: 6-7.5 mm, 0.24-0.30 in
Depth	58.5 mm (2.30")
Height	110 mm (4.33")
Weight	0.3 kg (0.66 lb.)

- (1) Fuse type: Subminiature fuse 3.15 A
- LT-5 Fast-Acting 622 series according to Littell fuse
 - TR5-F Fuse-link No. 370 according to Wickmann
 - MSF 250 according to Schurter

Dimensions

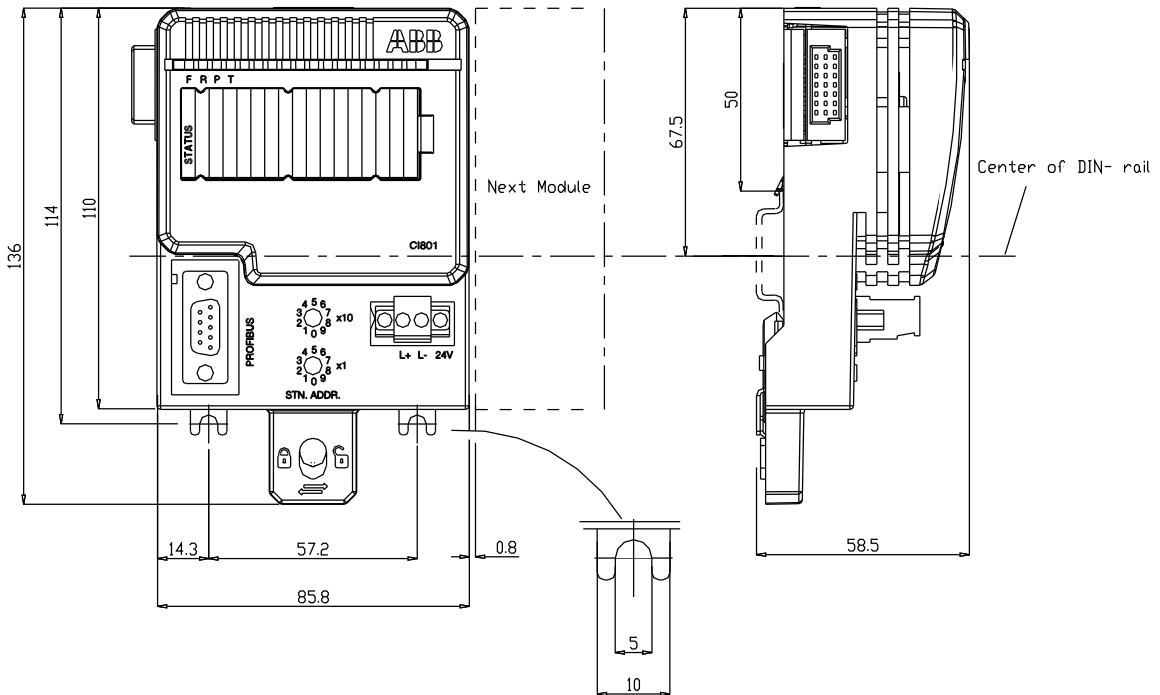

Figure 28. CI801 FCI Dimensions

Connections

Table 20. Power Supply Connections (XI)

Pin	Designation	Description
1	L+	+24 V d.c. Supply
2	L-	0 V d.c. Supply

Table 21. FCI PROFIBUS Connections (X2), Also Used as Service Port

Pin	Designation	Description
1	Shield	Shield/protective ground
2	NC	Not used
3	RxD/TxD-P	Receive data/transmit data positive
4	RTS	Direction control (optional)
5	DGND	Data ground
6	VP	Supply of termination resistance (5V)
7	NC	Not used
8	RxD/TxD-N	Receive data/transmit data negative
9	DGND	Data ground (if RTS is used)

Block Diagram CI801

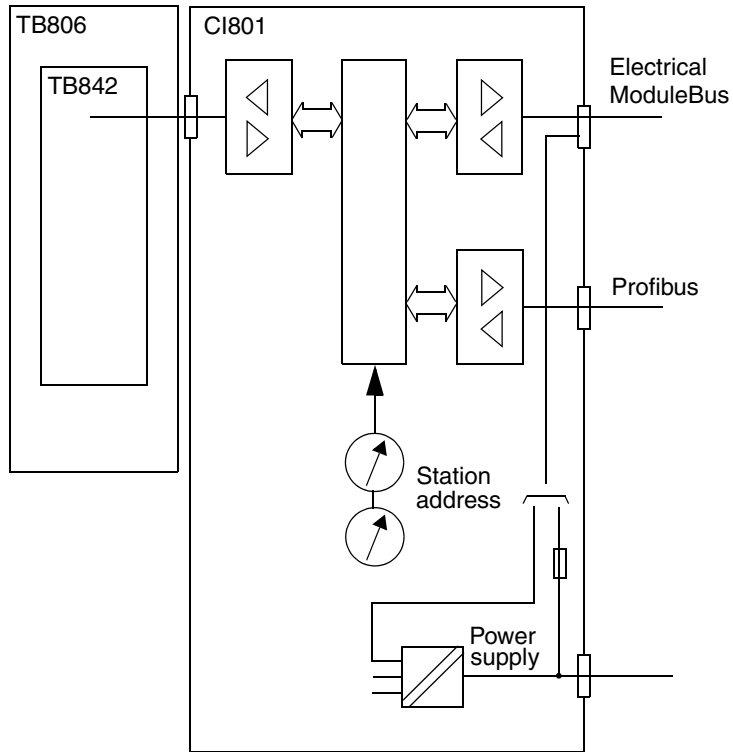

Figure 29. Block Diagram CI801

CI830 Fieldbus Communications Interface (FCI)

Features

- PROFIBUS-DP fieldbus interface.
- Supervisory functions of I/O ModuleBus.
- Isolated power supply to I/O modules.
- OSP handling and configuration.
- DIN rail mounting.

Description

The CI830 Fieldbus Communications Interface (FCI) is an intelligent communication interface between a Controller via the PROFIBUS-DP fieldbus and the S800 I/O modules via the ModuleBus.

CI830 has four basic parts: Module termination board, power supply board, processor board and the optical port (see block diagram).

The power supply board has an isolated power converter that generates a short circuit proof +5 V supply for the CI830 and I/O modules. It also contains opto-isolated RS232 drivers/receivers for the service port.

The Processor board contains the CPU, RAM, Flash PROM, ModuleBus interfaces, PROFIBUS-DP protocol chip, LED indicators and two rotary switches for the units PROFIBUS station address.

The termination board is a unit where most of the connections to the outside takes place. It is grounded to the DIN-rail through a metallic spring connector. The board carries screw terminals for power supply and redundant power supply monitoring,

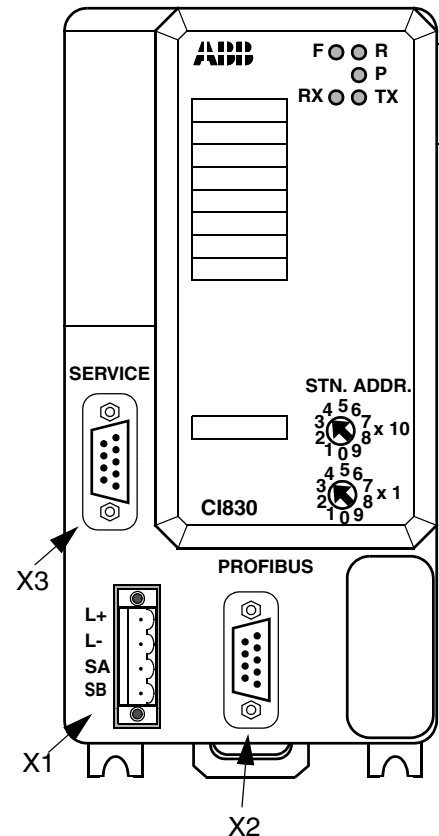

D-way terminal for PROFIBUS, connector for the service port, connector for the Optical ModuleBus Port TB810/TB811 and the electrical ModuleBus.

Technical Data

Table 22. CI830 FCI Specification

Item	Description
Microprocessor (CPU)	Motorola MC68340 running at 8 bit mode with a speed of 16 MHz
Flash PROM	512 kbyte
Fast RAM	256 kbyte (backed-up)
Power Input	24 V d.c. (19.2 - 30)
Power Consumption at 24 V d.c.	110 mA
Power Dissipation	2.6 W
Maximum Ambient Temperature	55°C (131°F)
Power Supply Monitoring Inputs	Max. input voltage: 30 V Min. input voltage for high level: 15 V Max. input voltage for low level: 8 V
Service Port (D-sub 9-pole female socket)	Opto-isolated (RS-232); 19.2 Kbaud/s maximum
PROFIBUS (D-sub 9-pole female socket)	Opto-isolated (RS-485); 12 Mbit/s maximum
ModuleBus	Maximum of 12 I/O modules
Power Output - ModuleBus	24 V max. = 1.4 A 5 V max. = 1.5 A Current limited
Safety classification	Class I according to IEC 536; (earth protected)

Table 22. CI830 FCI Specification (Continued)

Item	Description
Protection rating	IP20 according to IEC 529, (IEC 144)
Rated insulation voltage	50 V
Dielectric test voltage	500 V a.c.
Acceptable wire sizes	0.25 - 2.5mm ² , 24 - 14 AWG Recommended torque: 0.5 - 0.6 Nm Stripping length: 6-7.5 mm, 0.24-0.30 in
Width	84 mm (3.3")
Depth	122 mm (4.8")
Height	170 mm (6.7") including latch
Weight	0.45 kg (1.0 lb.)

Dimensions

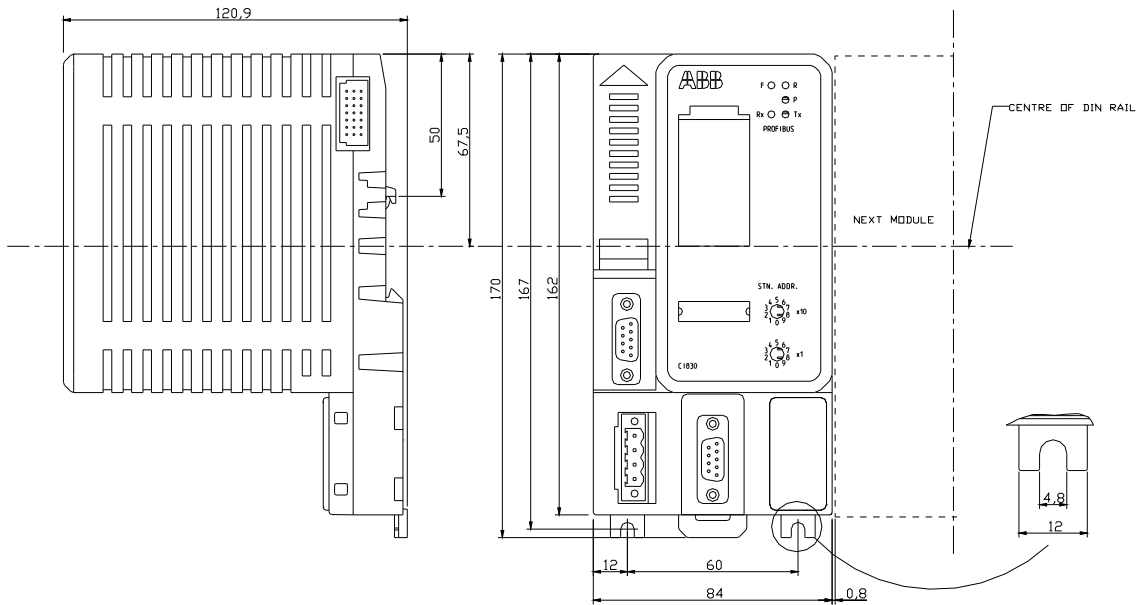

Figure 30. CI830 FCI Dimensions

Connections

Table 23. Power Supply Connections (XI)

Pin	Designation	Description
4	L+	+24 V d.c. Supply
3	L-	0 V d.c. Supply
2	SA	Redundant Power Supply "A" Monitoring Input
1	SB	Redundant Power Supply "B" Monitoring Input

Table 24. Service Port (X3)

Pin	Designation	Description
1		
2	TD	Transmit Data channel B
3	RD	Receive Data channel B
4		
5	SG	Signal Ground
6		
7	RDA	Receive Data channel A (for debugging only)
8	TDA	Transmit Data channel A (for debugging only)
9		

Table 25. FCI PROFIBUS Connections (X2)

Pin	Designation	Description
1	Shield	Shield/protective ground
2	-	Not used
3	RxD/TxD-P	Receive/Transmit data - plus
4	-	Not used
5	DGND	Data ground
6	VP	Supply voltage for the terminating resistors
7	-	Not used

Table 25. FCI PROFIBUS Connections (X2) (Continued)

Pin	Designation	Description
8	RxD/TxD-N	Receive/Transmit data - minus
9	-	Not used

Block Diagram C1830

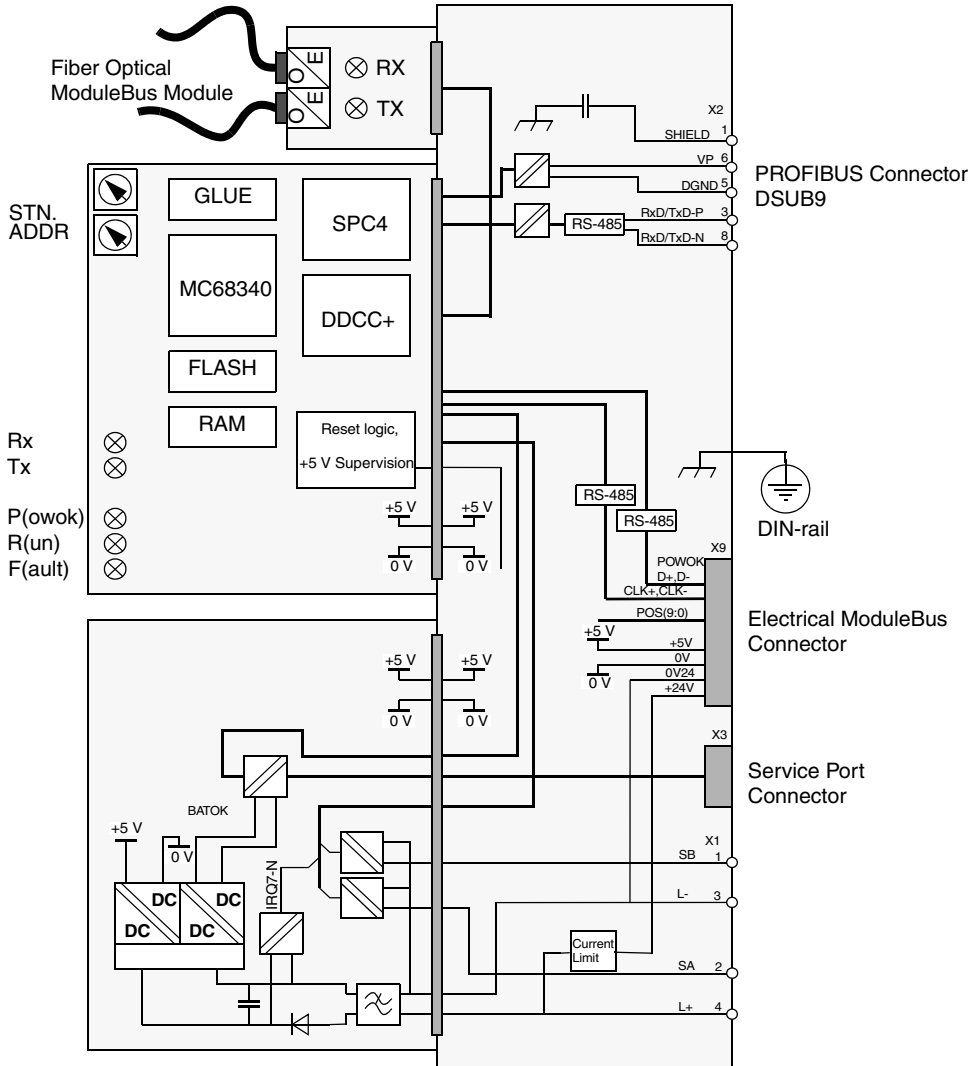

CI840 Fieldbus Communications Interface (FCI)

Features

- PROFIBUS-DPV1 fieldbus interface.
- Supervisory functions of I/O ModuleBus.
- Isolated power supply to I/O modules.
- OSP handling and configuration.
- Input power fused.
- Hot Configuration In Run.
- HART pass-through.

Description

The CI840 Fieldbus Communications Interface (FCI) is an intelligent communication interface between a Controller via the PROFIBUS-DPV1 fieldbus and the S800 I/O modules via the ModuleBus.

CI840 is designed to be used in redundant applications.

CI840 contains one PROFIBUS-DPV1 interface, two electrical ModuleBus interfaces, LED indicators and a opto-isolated RS232 service port.

CI840 has isolated power converters that generates internal power for CI840 and current limited +5 V supply for two electrical ModuleBuses.

Besides +5 V CI840 also distribute a current limited 24 V for the two ModuleBuses.

CI840 must be mounted on a Module Termination Unit TU846 or TU847. With CI840 mounted on a TU847, only one electrical ModuleBus is connected. When mounted on a TU846, two electrical ModuleBuses are connected.

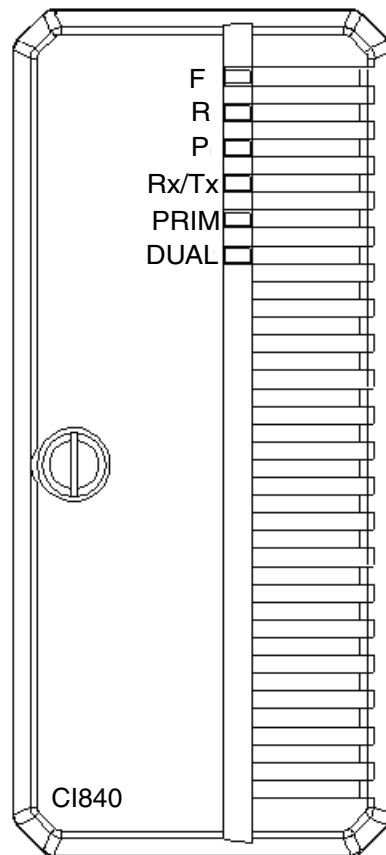

The Module Termination unit is DIN-rail mounted and grounded to the DIN-rail. The Module Termination Unit TU847 carries screw terminals for power supply and redundant power supply monitoring, two D-way terminals for PROFIBUS, two connectors for the service ports, one connector for the Optical ModuleBus Port TB842, mounted on TB806, and one electrical ModuleBus.

The Module Termination Unit TU846 carries screw terminals for power supply and redundant power supply monitoring, two D-way terminals for PROFIBUS, two connectors for the service ports, two connectors for the Optical ModuleBus Port TB842, mounted on TB846, and two electrical ModuleBuses.

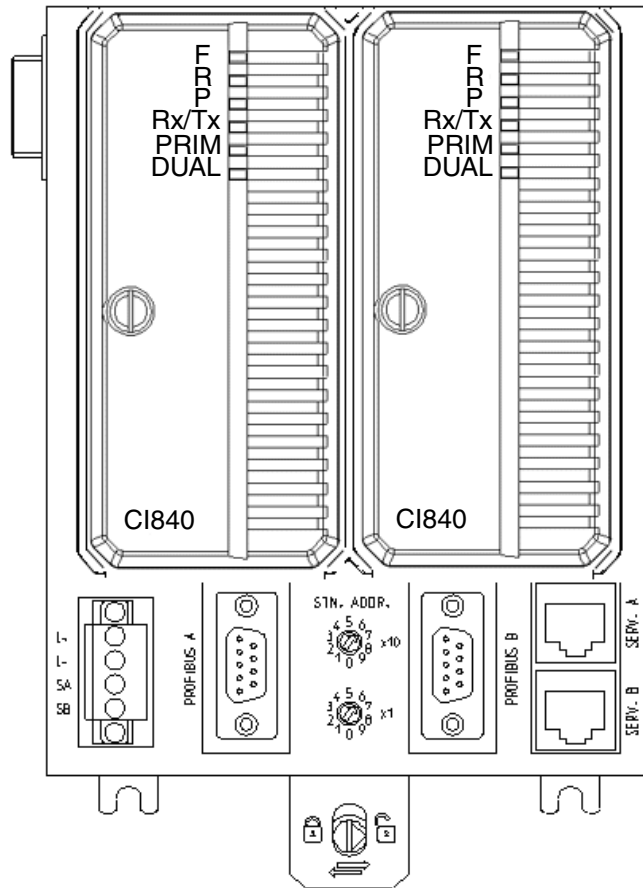

Figure 31. CI840 and TU847

Technical Data

Table 26. CI840 FCI Specification

Item	Description
Microprocessor (CPU)	Motorola MCF5307 with a speed of 64 MHz
Flash PROM	1 Mbyte
Fast RAM	8 Mbyte
Power Input	24 V d.c. (19.2 - 30)
Power Input Fuse	2 AF
Power Consumption at 24 V d.c.	190 mA
Power Dissipation	7.7 W
Maximum Ambient Temperature	55°C (131°F) horizontal mounted 40°C (104°F) vertical mounted
Power Supply Monitoring Inputs	Max. input voltage: 30 V Min. input voltage for high level: 15 V Max. input voltage for low level: 8 V
Service Port (RJ 45 connector on TU847)	Opto-isolated (RS-232); 19.2 Kbaud/s maximum
PROFIBUS (D-sub 9-pole female socket)	Opto-isolated (RS-485); 12 Mbit/s maximum
ModuleBus	Maximum of 12 I/O modules
Power Output - ModuleBus	24 V max. = 1.4 A 5 V max. = 1.5 A Current limited
Switch over time at failure in a redundant CI840 unit	Typical <100 ms Maximum 150 ms

Table 26. CI840 FCI Specification (Continued)

Item	Description
Switch over time at communication error on Profibus used by primary CI840	Typical < Watchdog Time ⁽¹⁾ + 50ms + (6 * Profibus cycle time)
Time to OSP in case of communication error on Profibus	Single FCI: Watchdog Time ⁽¹⁾ + (2 * Modulebus cycle time) Redundant FCI: Watchdog Time ⁽¹⁾ + Output Hold Time + (2 * Modulebus cycle time)
MTU Keying code	AA
Safety classification	Class I according to IEC 536; (earth protected)
Protection rating	IP20 according to IEC 529, (IEC 144)
Rated insulation voltage	50 V
Dielectric test voltage	500 V a.c.
Acceptable wire sizes	0.25 - 2.5mm ² , 24 - 14AWG, Recommended torque: 0.5 - 0.6 Nm Stripping length: 6 - 7.5 mm, 0.24 - 0.30 in
Width	54 mm (2.13")
Depth	96 mm (3.78")
Height	119 mm (4.69")
Weight	0.2 kg (0.44 lb.)

(1) Watchdog Time is set by the Profibus master.

Connections

See [Connections](#) on page 124.

Block Diagram CI840, single ModuleBus

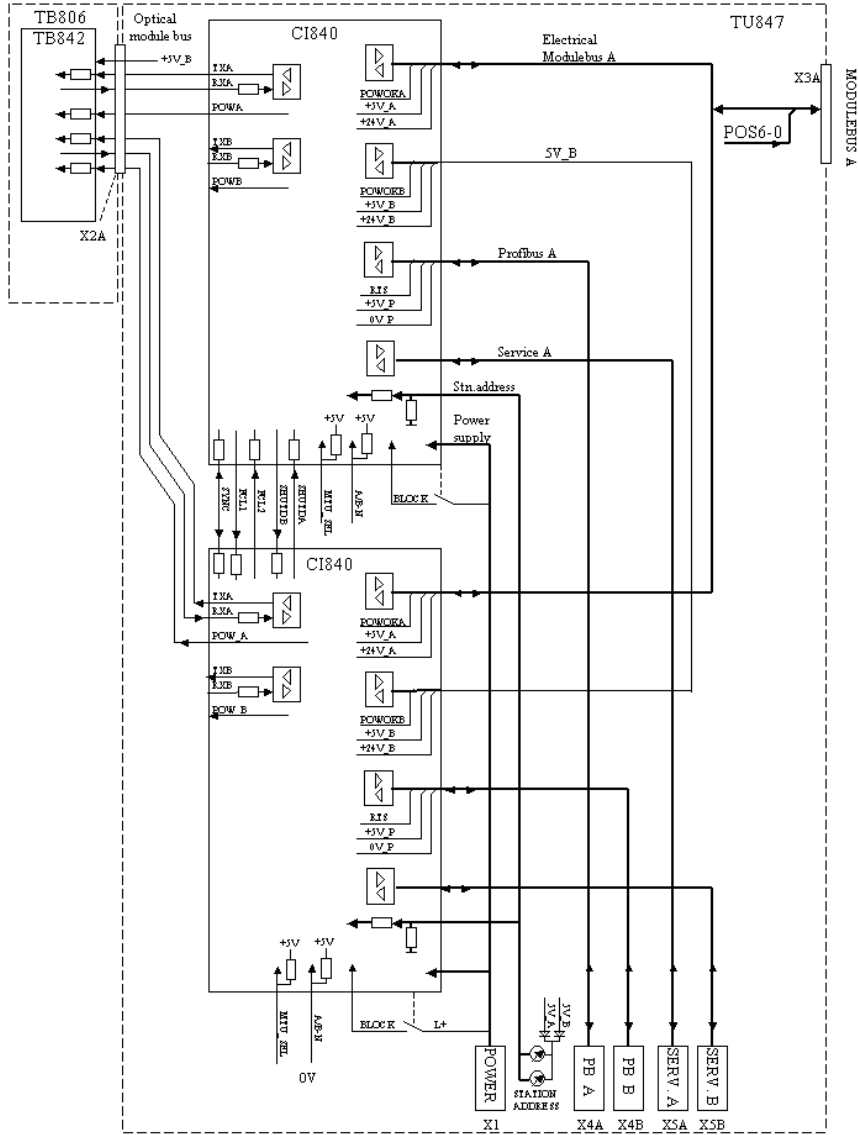

Figure 32. Block Diagram CI840, single ModuleBus

Block Diagram CI840, dual ModuleBus

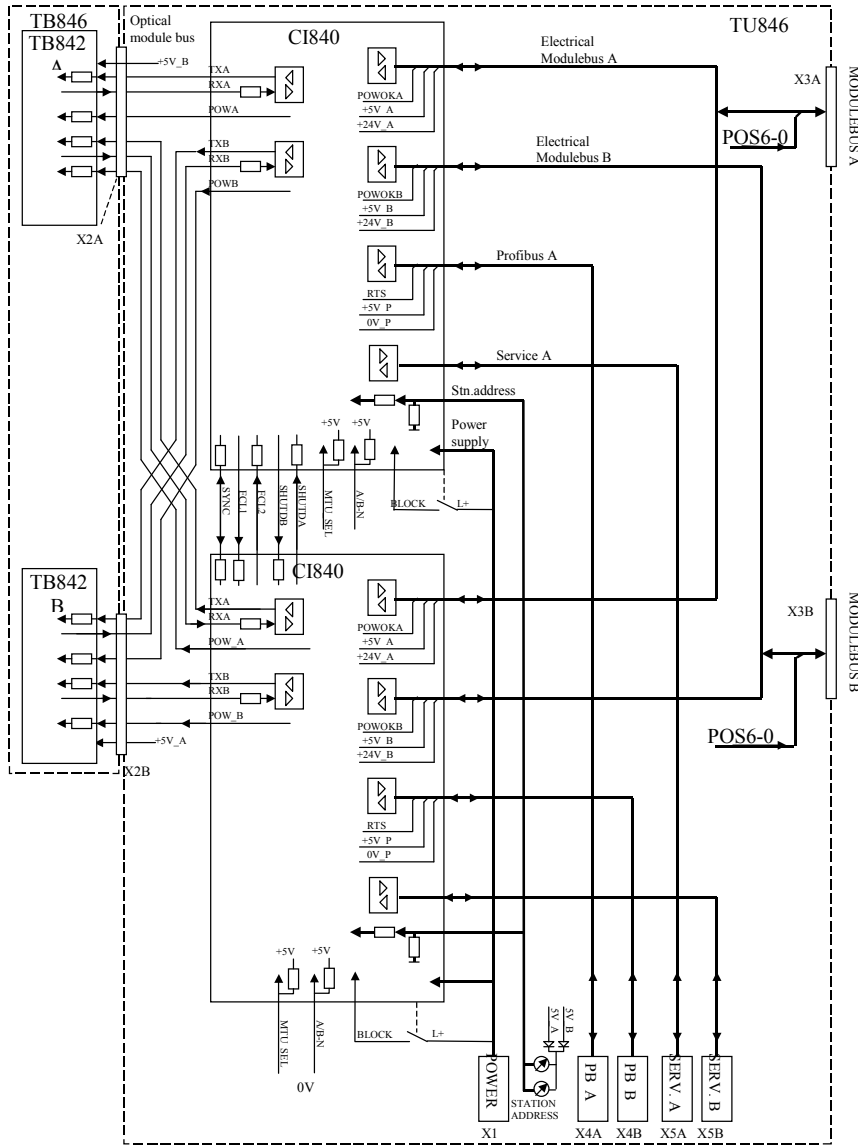
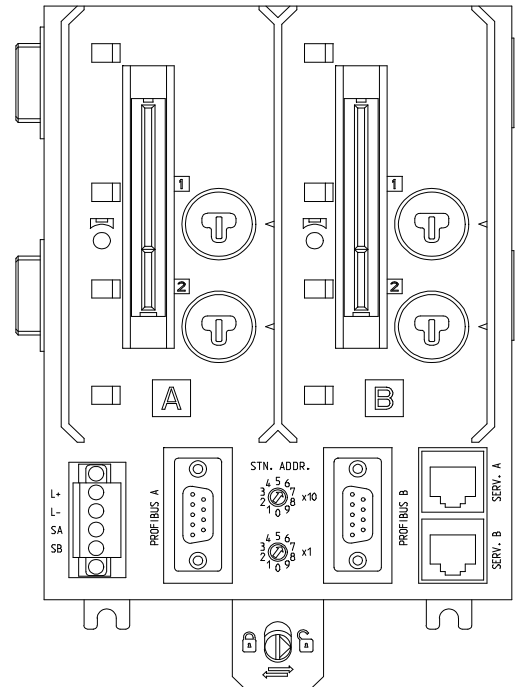

Figure 33. Block Diagram CI840, dual ModuleBus

TU846 Redundant MTU for CI840, dual ModuleBus

Features

- Power supply connection.
- Two PROFIBUS connections.
- Two service tool connections.
- Two rotary switch for station address setting.
- Connection for two ModuleBuses.
- Connector for ModuleBus Optical Port.
- Mechanical keying prevents insertion of the wrong module type.
- Latching device to DIN rail for locking and grounding.
- DIN rail mounted.



Description

The TU846 is a module termination unit (MTU) for redundant configuration of the field communication interface CI840 and redundant I/O.

The MTU is a passive unit having connections for power supply, two electrical ModuleBuses, two CI840 and two rotary switches for station address (0 to 99) settings.

A ModuleBus Optical Port TB842 can be connected to TU846 via TB846.

Four mechanical keys, two for each position, are used to configured the MTU for the right types of modules. Each key has six positions, which gives a total number of 36 different configurations. The configurations can be changed with a screwdriver.

The MTU can be mounted on a standard DIN rail. It has a mechanical latch that locks the MTU to the DIN rail. The latch can be locked/unlocked with a screwdriver.

The MTU has two BLOCK signals, one for each module position, that keeps the modules in its init state until it is locked in its position.

Technical Data

Table 27. TU846 Redundant MTU for CI840

Item	Value
Power input	24 V d.c. (19.2 - 30 V)
PROFIBUS connection	DSUB9 connector
Service ports	RJ45 connector
ModuleBus current distribution Maximum 5 V Maximum 24 V	1.5 A 1.5 A
Mechanical keys (2)	36 different combinations
Safety Classification	Class I according to IEC 536; (earth protected)
Protection Rating	IP20 according to IEC 529, (IEC 144)
Rated insulation voltage	50 V
Dielectric test voltage	500 V a.c.
Width	124 mm (4.88")
Acceptable wire sizes	0.25 - 2.5mm ² , 24 - 14 AWG Recommended torque: 0.5 - 0.6 Nm Stripping length: 6-7.5 mm, 0.24-0.30 in
Depth	47 mm (1.85")

Table 27. TU846 Redundant MTU for CI840 (Continued)

Item	Value
Height	186 mm (7.32") including latch
Weight	0.5 kg (1.1 lbs.)

Dimensions

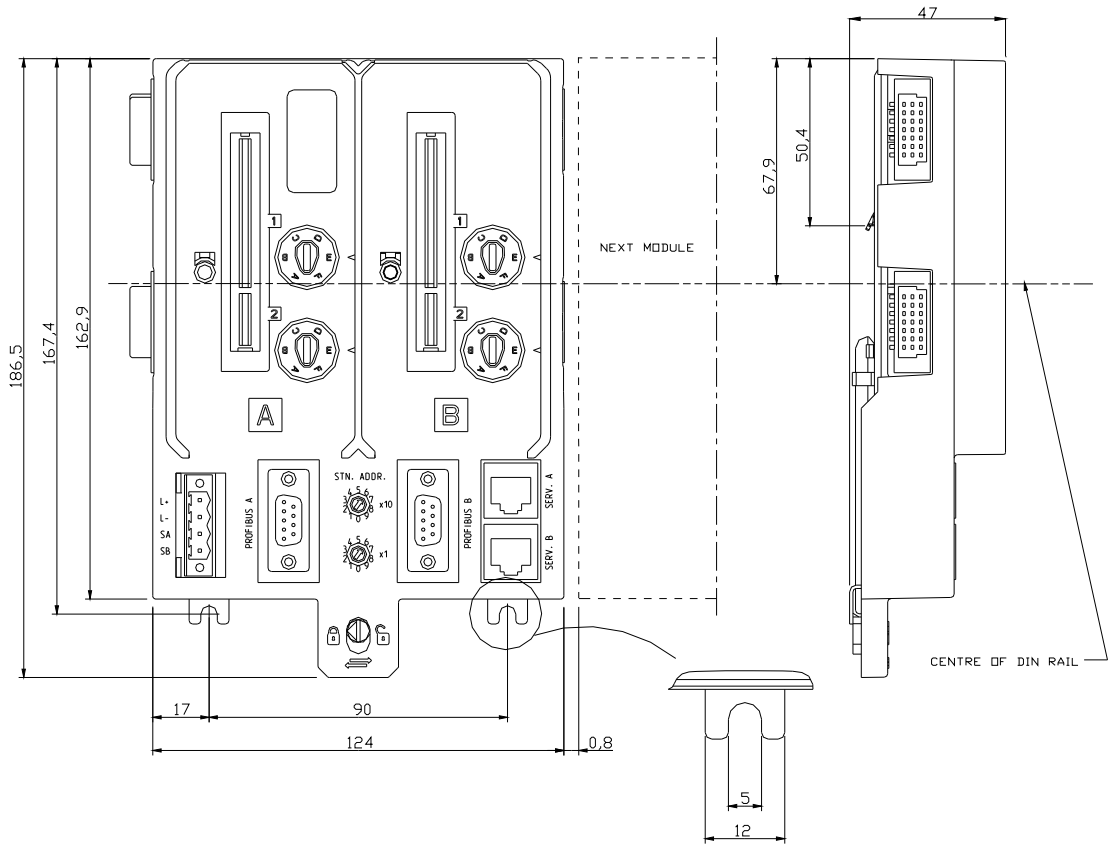

Figure 34. Dimensions TU846

Connections

Table 28. TU846 Power Supply Connections

Designation	Description
L+	+24 V d.c. Supply In
L-	0 V d.c. Supply In
SA	Redundant Power Supply "A" Monitoring Input
SB	Redundant Power Supply "B" Monitoring Input

Table 29. PROFIBUS Connector Pin-out

Pin	Designation	Description
1	Shield	Shield/protective ground
2	NC	Not used
3	RxD/TxD-P	Receive data/transmit data positive
4	RTS	Direction control (optional)
5	DGND	Data ground
6	VP	Supply of termination resistance (5V)
7	NC	Not used
8	RxD/TxD-N	Receive data/transmit data negative
9	DGND	Data ground (if RTS is used)

Table 30. Service Port Connector Pin-out

Pin	Designation	Description
1	NC	Not used
2	NC	Not used
3	Tx	Transmitted data

Table 30. Service Port Connector Pin-out (Continued)

Pin	Designation	Description
4	GND	Signal ground
5	GND	Signal ground
6	Rx	Receive data
7	NC	Not used
8	NC	Not used

Block Diagram TU846

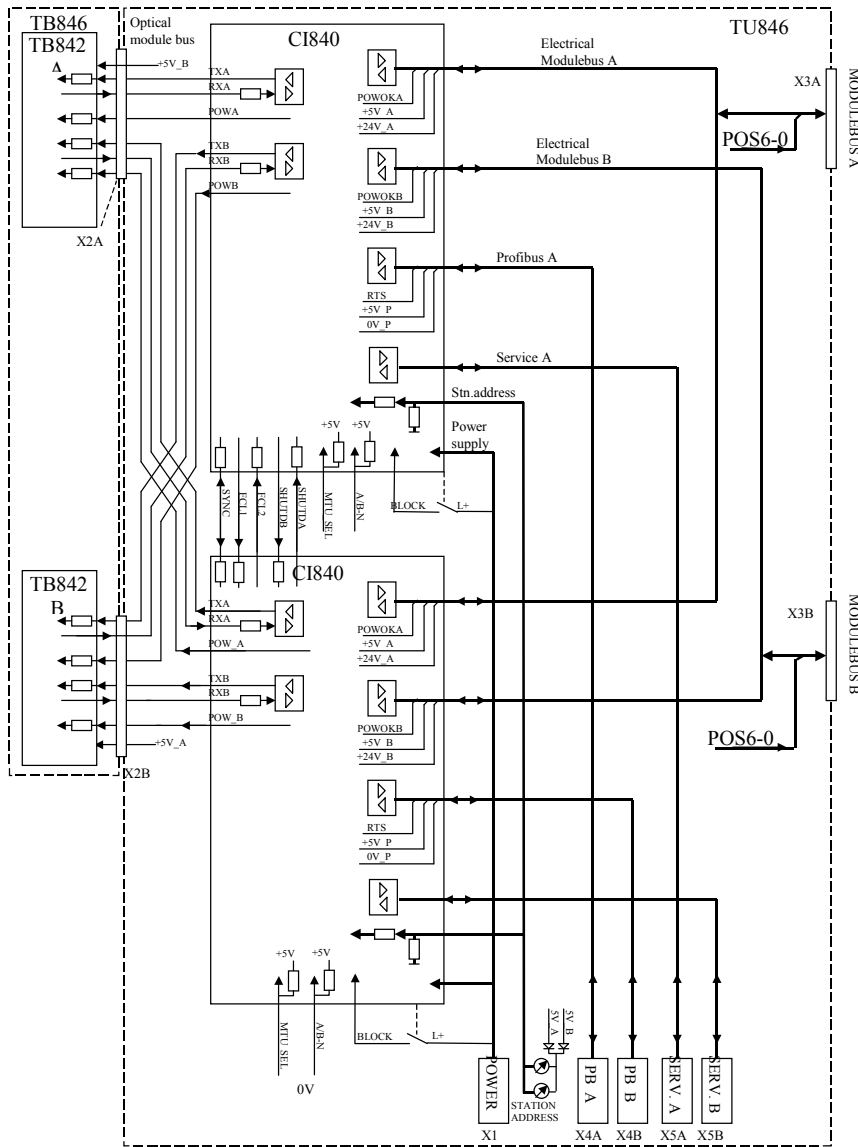
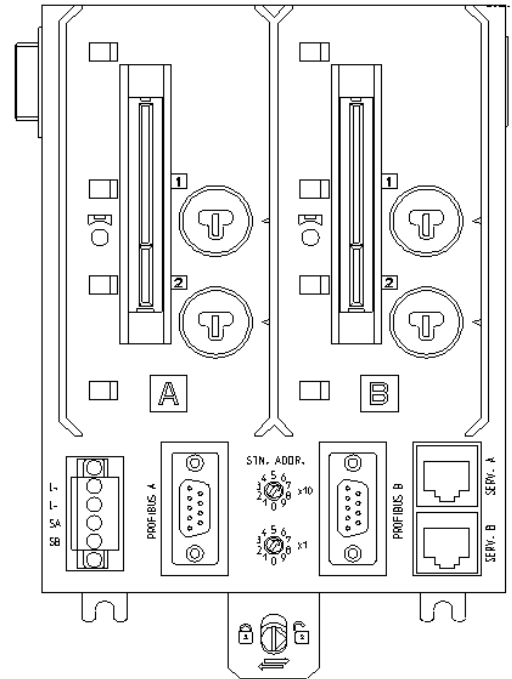

Figure 35. Block Diagram TU846

TU847 Redundant MTU for CI840, single ModuleBus

Features

- Power supply connection.
- Two PROFIBUS connections.
- Two service tool connections.
- Two rotary switch for station address setting.
- ModuleBus connections.
- Connector for ModuleBus Optical Port.
- Mechanical keying prevents insertion of the wrong module type.
- Latching device to DIN rail for locking and grounding.
- DIN rail mounted.



Description

The TU847 is a module termination unit (MTU) for redundant configuration of the field communication interface CI840.

The MTU is a passive unit having connections for power supply, electrical ModuleBus, two CI840 and two rotary switches for station address (0 to 99) settings.

A ModuleBus Optical Port TB842 can be connected to TU847 via TB806.

Four mechanical keys, two for each position, are used to configured the MTU for the right types of modules. Each key has six positions, which gives a total number of 36 different configurations. The configurations can be changed with a screwdriver.

The MTU can be mounted on a standard DIN rail. It has a mechanical latch that locks the MTU to the DIN rail. The latch can be locked/unlocked with a screwdriver.

The MTU has two BLOCK signals, one for each module position, that keeps the modules in its init state until it is locked in its position.

Technical Data

Table 31. TB847 Redundant MTU for CI840

Item	Value
Power input	24 V d.c. (19.2 - 30 V)
PROFIBUS connection	DSUB9 connector
Service ports	RJ45 connector
ModuleBus current distribution Maximum 5 V Maximum 24 V	1.5 A 1.5 A
Mechanical keys (2)	36 different combinations
Safety Classification	Class I according to IEC 536; (earth protected)
Protection Rating	IP20 according to IEC 529, (IEC 144)
Rated insulation voltage	50 V
Dielectric test voltage	500 V a.c.
Width	124 mm (4.88")
Acceptable wire sizes	0.25 - 2.5mm ² , 24 - 14 AWG Recommended torque: 0.5 - 0.6 Nm Stripping length: 6-7.5 mm, 0.24-0.30 in
Depth	47 mm (1.85")

Table 31. TB847 Redundant MTU for CI840 (Continued)

Item	Value
Height	186 mm (7.32") including latch
Weight	0.5 kg (1.1 lbs.)

Dimensions

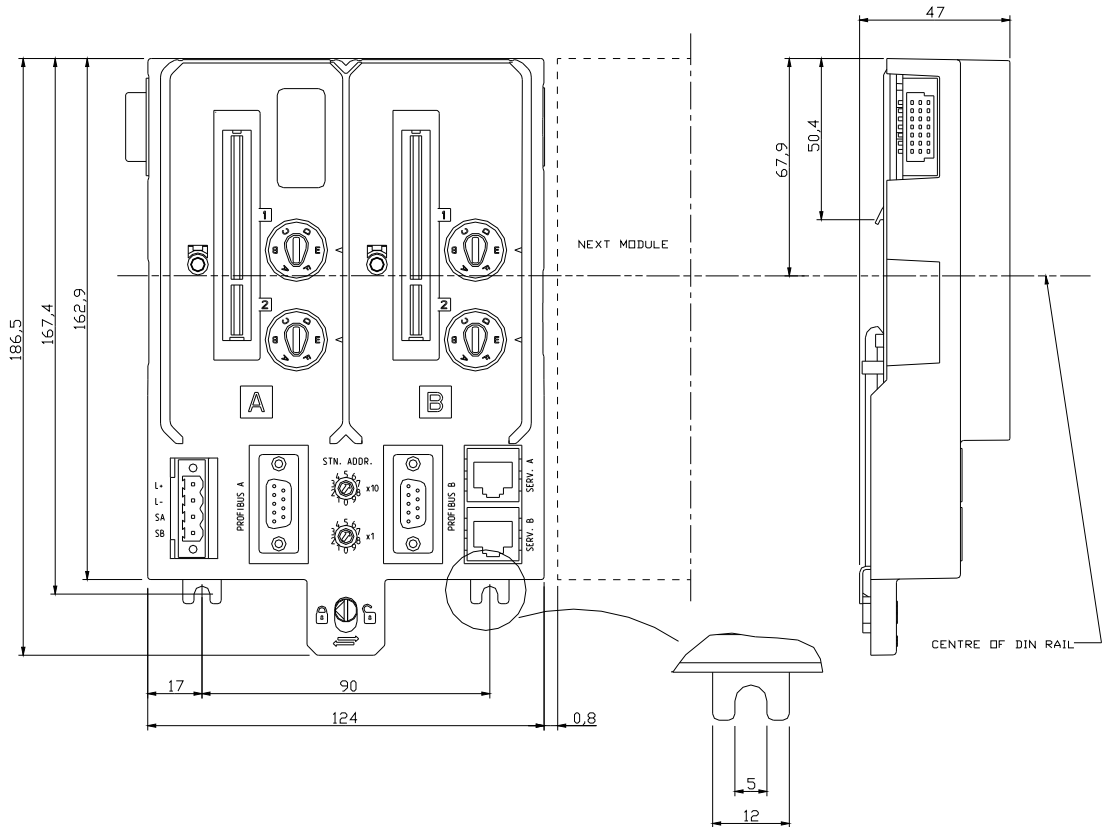

Figure 36. Dimensions TU847

Connections

Table 32. TU847 Power Supply Connections

Designation	Description
L+	+24 V d.c. Supply In
L-	0 V d.c. Supply In
SA	Redundant Power Supply "A" Monitoring Input
SB	Redundant Power Supply "B" Monitoring Input

Table 33. PROFIBUS Connector Pin-out

Pin	Designation	Description
1	Shield	Shield/protective ground
2	NC	Not used
3	RxD/TxD-P	Receive data/transmit data positive
4	RTS	Direction control (optional)
5	DGND	Data ground
6	VP	Supply of termination resistance (5V)
7	NC	Not used
8	RxD/TxD-N	Receive data/transmit data negative
9	DGND	Data ground (if RTS is used)

Table 34. Service Port Connector Pin-out

Pin	Designation	Description
1	NC	Not used
2	NC	Not used
3	Tx	Transmitted data

Table 34. Service Port Connector Pin-out (Continued)

Pin	Designation	Description
4	GND	Signal ground
5	GND	Signal ground
6	Rx	Receive data
7	NC	Not used
8	NC	Not used

Block Diagram TU847

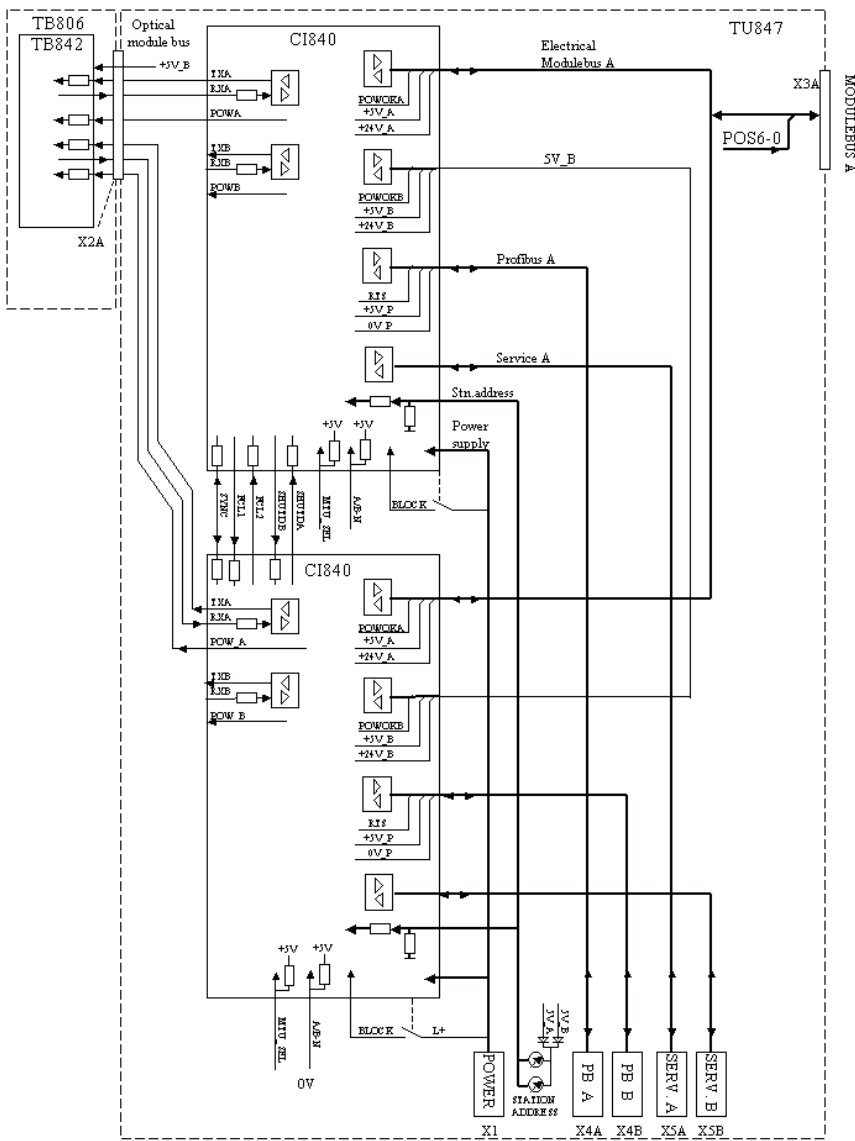

Figure 37. Block Diagram TU847

INDEX

C

CI830 16, 19, 22, 81 to 82, 84, 89
Connections
 Power supply 34, 37, 41
 PROFIBUS-DP 32, 35, 39

D

Data scanning principles 66

E

Error state 70

F

FCI 12, 16, 19, 22, 63, 81 to 82, 95, 101, 108
FCI module 17, 20, 22
Fieldbus communications interface 95, 101, 108

I

I/O module functionality
 PROFIBUS-DP 67
I/O station 13
Init state 69

L

LEDs
 FCI 73, 75, 77

N

Not configured state 69

O

Operational state 69
OSP 71
OSP state 70

P

Parameters
 Loading 71
 Loading invalid 71
 Non-volatile 71
PROFIBUS-DP 13, 16, 19, 22, 63
 I/O module functionality 67

R

Ready state 69

S

State
 Error 70
 Init 69
 Not configured 69
 Operational 69
 OSP (Outputs Set as Predefined) 70
 Ready 69
Station address selector
 PROFIBUS-DP 31, 35, 38

Contact us

ABB AB

Control Technologies

Västerås, Sweden

Phone: +46 (0) 21 32 50 00

e-mail: processautomation@se.abb.com

www.abb.com/controlsystems

ABB Automation GmbH

Control Technologies

Mannheim, Germany

Phone: +49 1805 26 67 76

e-mail: marketing.control-products@de.abb.com

www.abb.de/controlsystems

ABB S.P.A.

Control Technologies

Sesto San Giovanni (MI), Italy

Phone: +39 02 24147 555

e-mail: controlsystems@it.abb.com

www.abb.it/controlsystems

ABB Inc.

Control Technologies

Wickliffe, Ohio, USA

Phone: +1 440 585 8500

e-mail: industrialitsolutions@us.abb.com

www.abb.com/controlsystems

ABB Pte Ltd

Control Technologies

Singapore

Phone: +65 6776 5711

e-mail: processautomation@sg.abb.com

www.abb.com/controlsystems

ABB Automation LLC

Control Technologies

Abu Dhabi, United Arab Emirates

Phone: +971 (0) 2 4938 000

e-mail: processautomation@ae.abb.com

www.abb.com/controlsystems

ABB China Ltd

Control Technologies

Beijing, China

Phone: +86 (0) 10 84566688-2193

www.abb.com/controlsystems

Copyright © 2003-2013 by ABB.

All rights reserved.

3BSE020926-510 A

Power and productivity
for a better world™

