

ABB INDUSTRIAL DRIVES

ACS580MV Quick guide



List of related manuals

Drive hardware manuals and guides

	Code (English)
<i>ACS580MV hardware manual</i>	2UBB004520
<i>ACS-AP-X assistant control panels user's manual</i>	3AUA0000085685
<i>ACS580MV Engineering Guideline</i>	2UBB013672
<i>ACS580MV Base frame & TEU layout design</i>	2UBB020751
<i>ACS580MV Wiring Diagram of system 0</i>	2UBB005084
<i>ACS580MV Wiring Diagram of system 1</i>	2UBB005085
<i>ACS580MV Wiring Diagram of system 2</i>	2UBB005086
<i>User's manual Start-up and maintenance PC tool Drive composer</i>	3AUA0000094606
<i>ACS580MV Preventive Maintenance Schedule</i>	2UBB022658
<i>ACS580MV Synchronized Bypass Unit Hardware Manual</i>	2UBB005655
<i>ACS580MV Wiring Diagram of Synchronized Bypass Unit</i>	2UBB005212
<i>ACS580MV Synchronized Bypass unit Engineering Guideline</i>	2UBB005656
<i>ACS580MV Manual Bypass unit Hardware Manual</i>	2UBB005416
<i>ACS580MV Manual Bypass unit Engineering Guideline</i>	2UBB005683
<i>ACS580MV Air duct interface Outline Drawing AC Fan Box</i>	2UBB005072
<i>ACS580MV Air duct interface Outline Drawing EC Fan Box</i>	2UBB005074
<i>ACS580MV Layout Design of Drive with MBU</i>	2UBB005535
<i>ACS580MV Layout Design of Drive with ABU</i>	2UBB005534
<i>ACS580MV Layout Design of Drive with SBU</i>	2UBB005536
<i>ACS580MV Layout Design of Drive with SBM</i>	2UBB005537

Drive firmware manuals and guides

<i>ACS580MV primary control program firmware manual</i>	3BHS811381
---	----------------------------

Option manuals and guides

Manuals and quick guides for I/O extension modules, fieldbus adapters, etc.

You can find manuals and other product documents in PDF format on the Internet. See section Document library on the Internet on the inside of the back cover. For manuals not available in the Document library, contact your local ABB representative.

For more information, please refer to ACS580 MV Hardware Manual which can be found by scanning the QR code below:

APP version (IOS/Android)



Web page version



ACS580MV Quick guide

Table of contents



Safety instructions



Mechanical installation



Electrical installation



Replacing the memory unit



Table of contents

1. Safety instructions

Contents of this chapter	7
--------------------------------	---

2. Identifying a drive from package

Identifying a drive from package	9
--	---

3. Lifting and transportation

Safety	11
--------------	----

4. Mechanical installation

Safety	13
Examining the installation site	13
Installation of EC fan units	14
Installation	14
Bolting together the units	15
Location of tool kit and accessories	16

5. Electrical installation

Safety	17
Overview of installation work	17
Drawing of system cabling	18
Cables requirements	19
Cables and PE busbar between drive and integrated transformer and drive	19
Installing power and ground cables	22
Installing auxiliary, control and serial communication cables	25
Control and power supply cables for fan units	25
Sealing holes in entry plates	26

6. Installation checklist

Contents of this chapter	27
Checklist	28

7. Operation

Status indications	33
Energizing and starting the drive	34
Checks before starting the drive	34
Starting the drive from remote	34
Starting the drive locally	34
Stopping the drive	35



8. Fault tracing

Contents of this chapter	37
Warning and fault messages	37

9. replace the memory unit and Sd card

Replacing the memory unit	43
Replacing SD card	43
Product and service inquiries	44
Product training	44
Document library on the Internet	44



1

Safety instructions



Contents of this chapter

Safety instructions are used to highlight a potential hazard when working on the equipment. Safety instructions must be strictly followed! Non-compliance can jeopardize the safety of personnel, the equipment and the environment.



DANGER indicates a hazardous situation which, if not avoided, will result in death or serious injury.



WARNING indicates a hazardous situation which, if not avoided, could result in death or serious injury.



CAUTION indicates a hazardous situation which, if not avoided, could result in minor or moderate injury.



NOTICE is used to address practices not related to personal injury.

8 Safety instructions





Identifying a drive from package

Identifying a drive from package

Read package information from the drive package list.

- Drive serial number ①
- Total case quantity per drive ②
- Detail cases numbers under the drive ③
- Case dimension ④
- Gross weight and net weight ⑤



Package List / Virtual



Pkg Status:	Open		
Pkg.MM:	2UBA010400Z0001	Pkg.SN:	2UBA958000245 ①
SO/Line#:	501765166 /000300	Number of Case:	2 ②
Created by:	尉逸豪	Created Date:	4/17/2017 3:44:23PM
Last updated by:	尉逸豪	Last updated date:	4/24/2017 9:02:52AM

Line	CaseNumber ③	Type	Status	Location	L * W * H (cm) ④	G / N. weight (kg) ⑤	#Item
1		Virtual	Close	2116	217.00 * 152.00* 279.00	1,800.00 / 1,400.00	1
2		Virtual	Close	2116	257.00 * 152.00* 279.00	3,100.00 / 2,700.00	1

10 Identifying a drive from package

Check the cases number from case detail list. The detail goods description is shown. Find all cases under the drive based on the case numbers.



Case Detail List



Case Type :	Virtual	Case Status :	Close
Pkg Number :	PKN20004363	Pkg Status :	Open
Pkg Line / Cases :	1 / PYN2005894	Location :	2116
Created by :	尉逸豪	Created Date :	4/17/2017 3:44:23PM
Last update by :	尉逸豪	Last Update Date :	4/19/2017 2:40:27PM
L * W * H :	217.00 * 152.00 * 279.00 CM	Gross / Net weight :	1,800.00

Line	MM	Description / Type	SO	SOLine	Qty	Special In./Va.
1	2UBA010402R0001	ELECTRICAL KIT ACS580MV CONVERTER ACS580MV CONVERTER	501765166	000300	1.00	

Identifying a drive after unpacking

Read the label pasted at the bottom of inverter and transformer unit. Match them by same serial number on the main label.

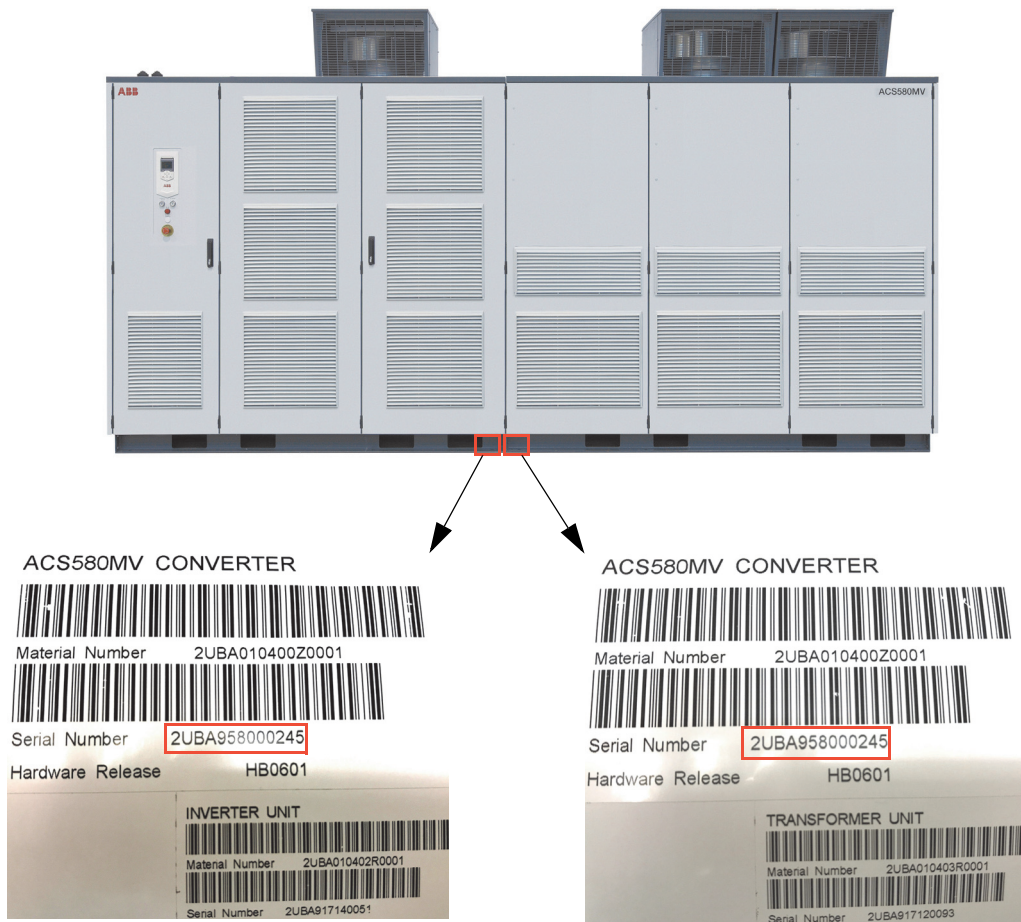

3

Lifting and transportation

Safety

- The drive must only be handled by personnel who are skilled and experienced in unpacking and transporting heavy equipment.
- All work must be carried out by qualified personnel according to the site and equipment.
- Choose the load capacity and find the center of gravity from ACS580MV outline drawing.

Using a crane or forklift

- Verify that the slope angle (1 in figure below) corresponds to the weight of the cabinet.
 - Only transport the cabinet with the long side facing the driving direction.
 - Use forks with sufficient length to ensure stable transportation and to prevent tipping.
 - The fork must be at least as long as the cabinet.
 - Insert the fork fully into the cabinet's forklift pockets.
-

12 Lifting and transportation

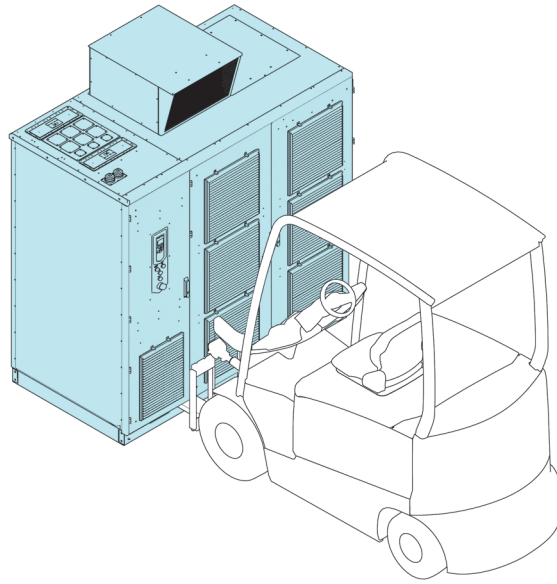
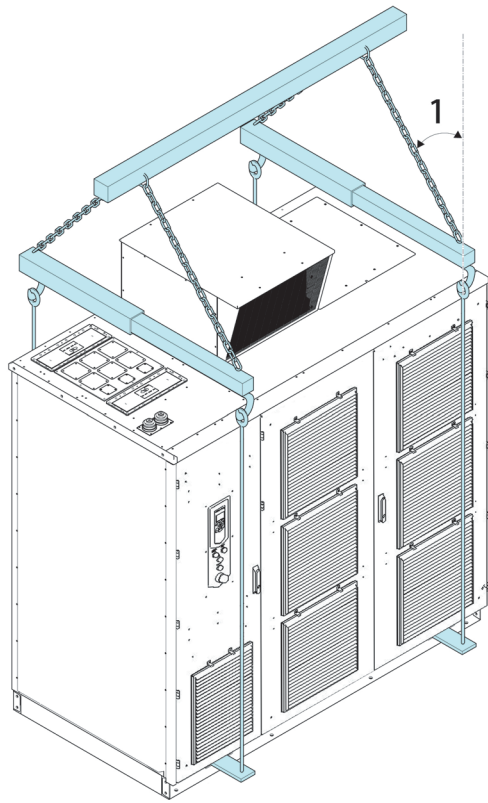

4

Mechanical installation

Safety

All installation work must be carried out by qualified personnel according to the site and equipment requirements and in compliance with the local regulations.

Examining the installation site

The installation site is sufficiently ventilated or cooled to transfer away the drive losses. The maximum heat losses and cooling air flow are listed in ACS580MV outline drawing.

The ambient conditions of the drive shall not be higher than 40°C during operation of the drive. In case the temperature out of the scope, contact ABB to get support.

ACS580MV can be installed using one of the four following cooling solutions:

- Air conditioner solution (Recommended)
- Air duct solution
- Fresh air circulation solution
- Air-to-water heat exchanger solution



14 Mechanical installation

Attention:

- The wall behind the unit is of non-flammable material.
- The floor that the unit is installed on is of non-flammable material.
- The maximum allowed floor flatness deviation from the surface level is 5mm in every 5 meters.
- Drive minimal distances to the walls:
 - Front side: 1600 mm
 - Rear side: 100 mm
 - Top side: 850 mm
 - Left side: 100 mm
 - Right side: 100 mm

Installation of EC fan units

AC fans are already mounted when delivered from works.

EC fans need to be installed with fan box in the field.

For information on the number of fan units to be installed, see [ACS580MV Outline Drawing](#).

Installation

1. Lift the fan unit onto the cabinet roof by means of a forklift or a crane (if using a crane, empty the lifting eyes in the fan roof).

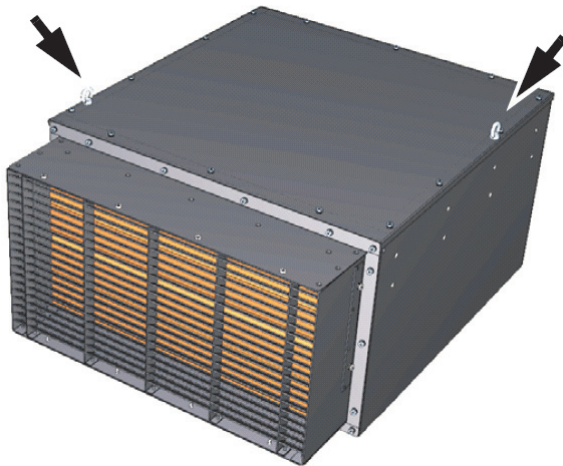

- ~70 kg for EC500 fan units
- ~90 kg for EC560 fan units

NOTICE

The mounting position can be identified by the cutouts in the drive roof.

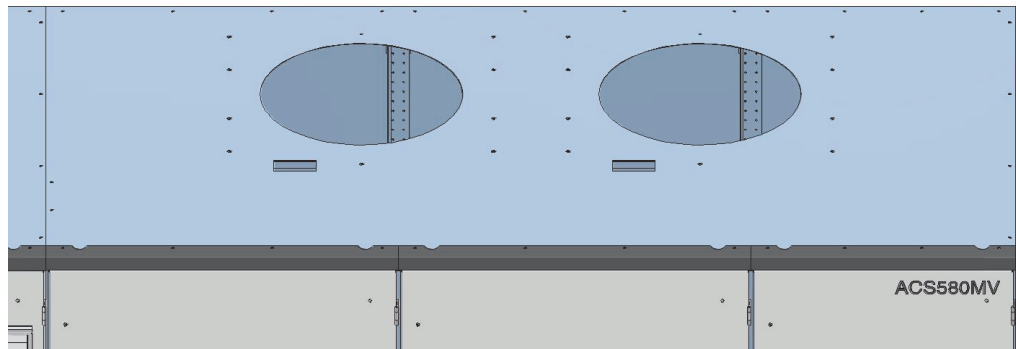

2. Use the supplied screws to fasten the fan units to the cabinet roof.

Bolting together the units

Required bolts are attached to the drive unit side wall adjoining the transformer unit. Align the units. Then bolt the units together using the 12 hexagonal bolts (see figure below).

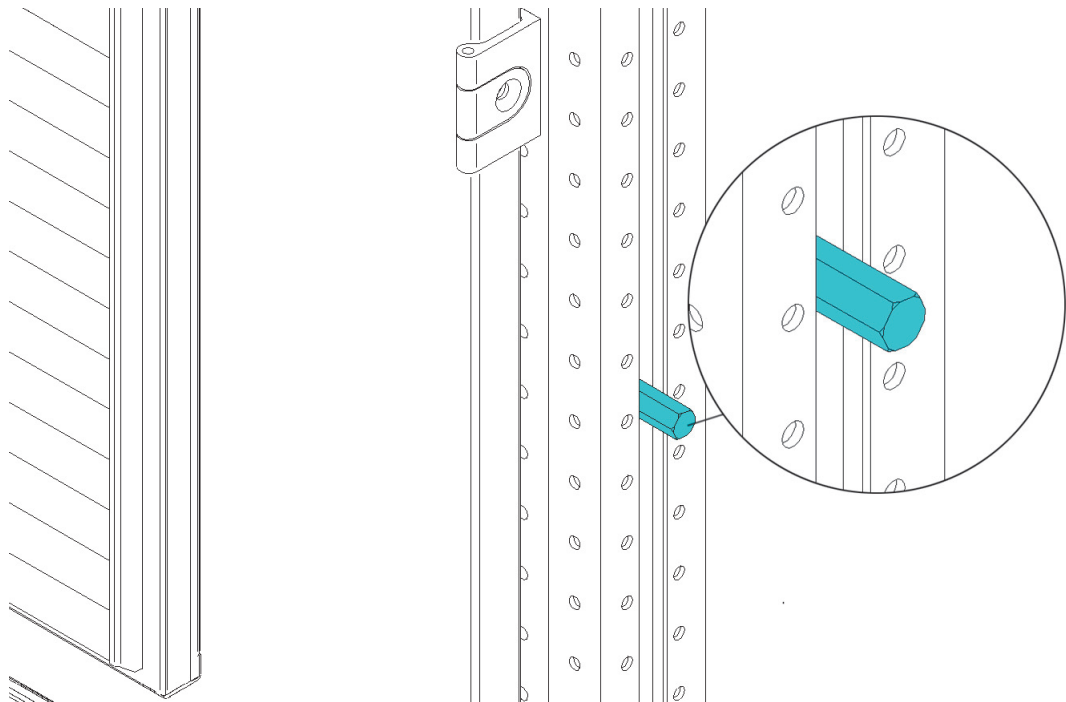

Floor fixings are not supplied. M16 anchor bolts as illustrated in figure below, or screws, nuts and washers of size M16 are recommended (diameter of holes in base frame: 18 mm). It is prohibited to solder the drive to the foundation.

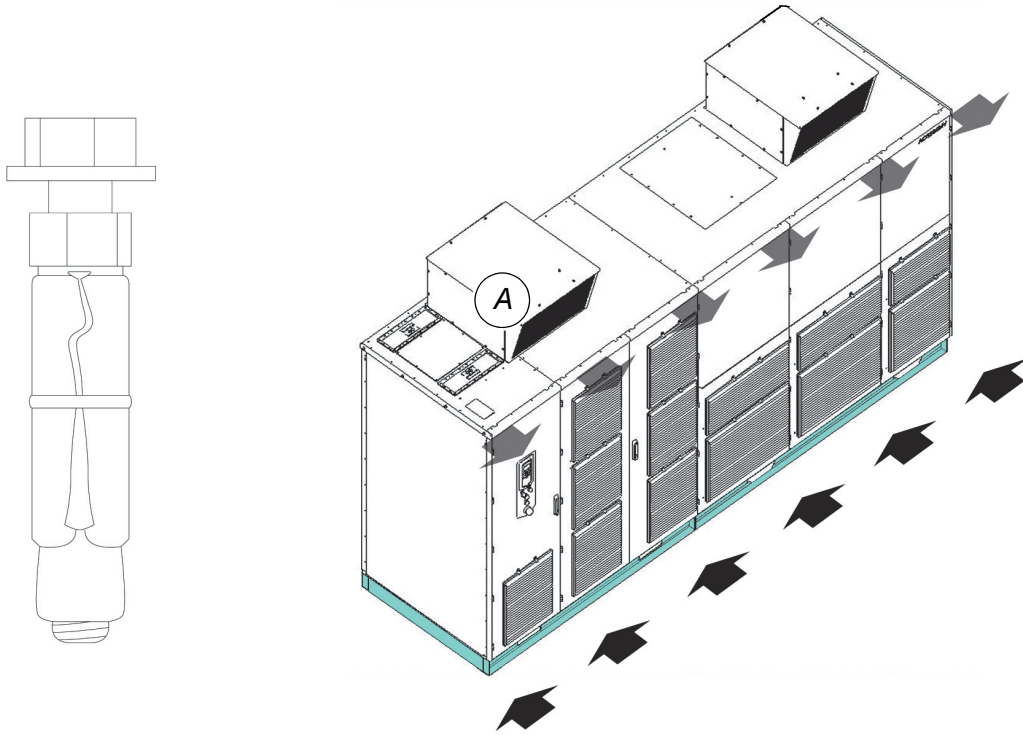

Fixing the base to the floor

Location of tool kit and accessories

Open the box, you can find all the tools and accessories for future use. A description of all the items in the kit is delivered alongside. Please pay attention to the screw driver which is used for open the transformer cabinet is in this box, it should be kept by authorized person, actions without authorization are dangerous.



1. **COU Key**

Key for control unit fix on the door of COU.

2. **Combination screws**

Screws for combining converter and transformer are fixed on the door of control unit.

3. **Tool Kit**

You can find the tool kit by open the door of control unit. It is on the bottom of the cabinet.

5

Electrical installation

Safety



WARNING Hazardous voltage!

Improper work could lead to life-threatening injury or death.

The electrical installation must be carried out by qualified personnel according to the site and equipment requirements, and the relevant electrical codes.

When the electrical installation is completed, the main and auxiliary power supply to the drive must not be switched on without the consent of the ABB commissioning personnel.

Take appropriate measures to prevent main and auxiliary power supply from being switched on during installation.



Overview of installation work

The electrical installation includes the following wire and cable connections:

- Cables between integrated transformer and drive
 - Power cables, ground cables, equipotential cable...
 - Auxiliary power, control and serial communication cables
 - Power supply and signal cables for fans (EC and AC)
 - Sealing holes in entry plates
 - Default control connections for the factory macro
-

Drawing of system cabling

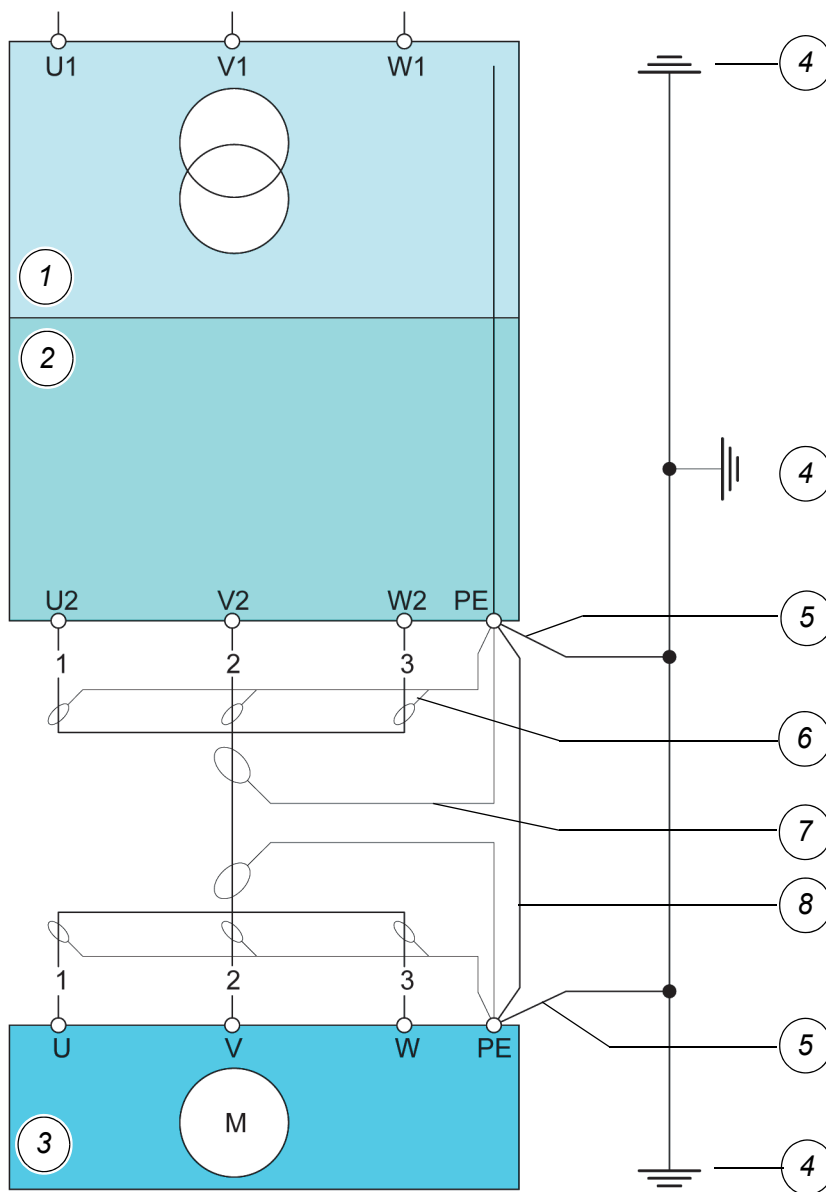

1	Input transformer (TRU)
2	Drive
3	Motor
4	Earth electrode
5	Ground cable
6	Cable screen
7	Cable shield
8	Equipotential bonding conductor

Cables requirements

In addition to below requirements, all electrical installations must comply with local standards and regulations, and the cable installation must be in line with the installation guidelines of the cable manufacture.

- Feeder cable requirements

No special requirements from converter point of view.

- Motor cable requirements

The table summarizes the requirements to the motor cable coming from the operation with an ACS580MV.

Converter type	Multi-level converter isolated from ground
Motor rated voltage (fundamental)	6.0kV/6.3kV/6.6kV/10.0kV/10.5kV/11kV
Cable insulation U0/U(Um), based on IEC60502-2, Categories A and B	Motor voltage 6/6.3/6.6kV: 3.6/6(7.2) Motor voltage 10/10.5/11kV: 6/10(12)
Max. cable length	1000 m
Max. number of parallel cables	2 (limited by terminals)
Special derating factors	For operation above 100 Hz, please consult reference [3] for skin effect
Derating due to converter operation	1.0

In case single-phase cables are used, they need to be installed in a triangle (trefoil) configuration.

If the overall cross section of the screen of the 3-phase system is >50% of the phase conductor cross section, no further precautions are have to be considered.

If the overall cross section is <50%, an additional equiptential bonding conductor is recommended in order to prevent overloading of the screen in case of potential differences in the plant. The minimum cross section of this conductor depends on the cable length:

- $\geq 50 \text{ mm}^2$, for cable length < 300 m
- $\geq 95 \text{ mm}^2$, for cable length > 300 m

The converter must be connected to system ground at one point. The ground point inside the converter is referred to as Protective Earth (PE).

The cross section of the ground cable must be $\geq 150 \text{ mm}^2$.

The connection to system ground has to be established in compliance with local regulations.

Cables and PE busbar between drive and integrated transformer and drive

Cables and PE busbar between drive and integrated transformer includes the following connections:

- Transformer primary and secondary cables. ①



20 Electrical installation

- Temperature sensor cables
 - Three-phase power supply cable to each of the transformer fan units ②
- or
- Auxiliary supply from internal main transformer (option)
 - Heating cable (option)
 - PE busbar between drive and integrated transformer ③

NOTICE

The required tightening torque for the internal transformer terminal connections is 15Nm(M8 bolt),30Nm(M10 bolt). Use a torque wrench.



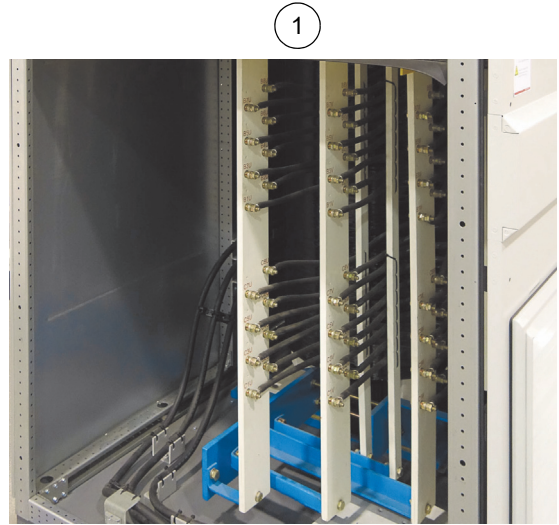
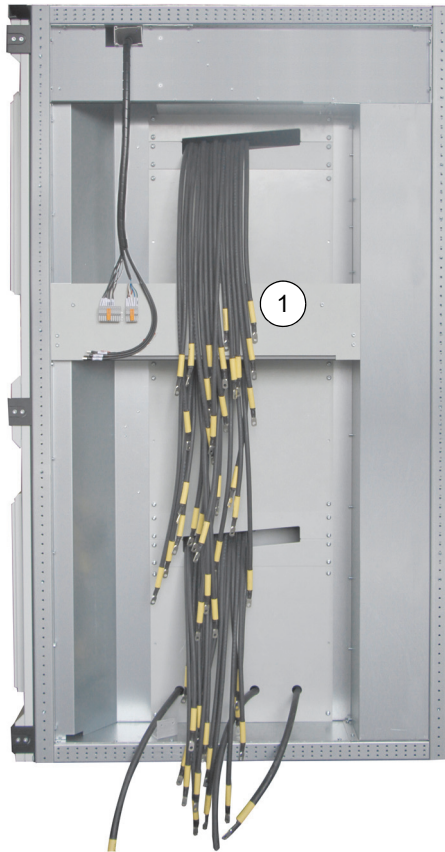

2



Installing power and ground cables

NOTICE

Waste inside the cabinet can cause damage or malfunction.

High voltages will be present in the terminal compartment. High voltages can cause flashover between the electric potential of different conductors, and the electric potential of a conductor and earth.

Therefore, a minimum clearance of **59.5 mm** must be maintained between a conductor and earth, and **90 mm** between a conductor and the terminals of any other conductor.

- Prepare the cable termination as illustrated in the figure below. The conductor screen must be connected to PE ground busbar. It is prohibited to cut off.

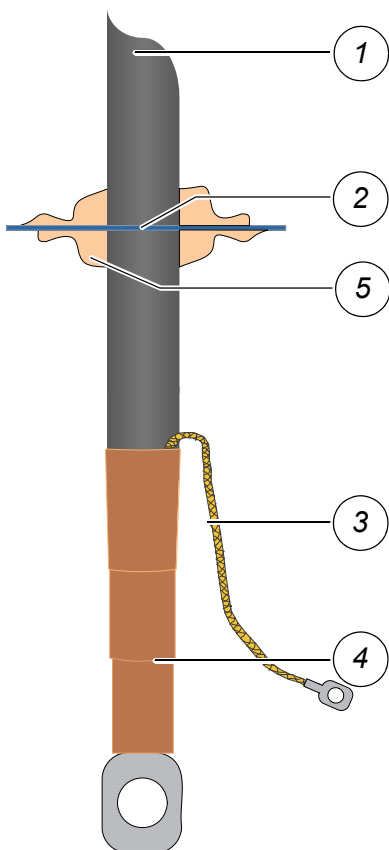

1	Outer cable sheath
2	Entry plate
3	Conductor screen extension to be connected to PE ground busbar
4	Heat-shrinkable termination
5	Sealing compound

Connect the cables to their corresponding busbars. Use cable lugs suitable for M12 bolts. The required tightening torque is 40 Nm.

- Feeder cables to busbars U1, V1, W1
- Motor cables to busbars U2, V2, W2
- Screen ends of all conductors and the shields of all cables to the PE ground busbar
- Ground cable to the PE ground busbar

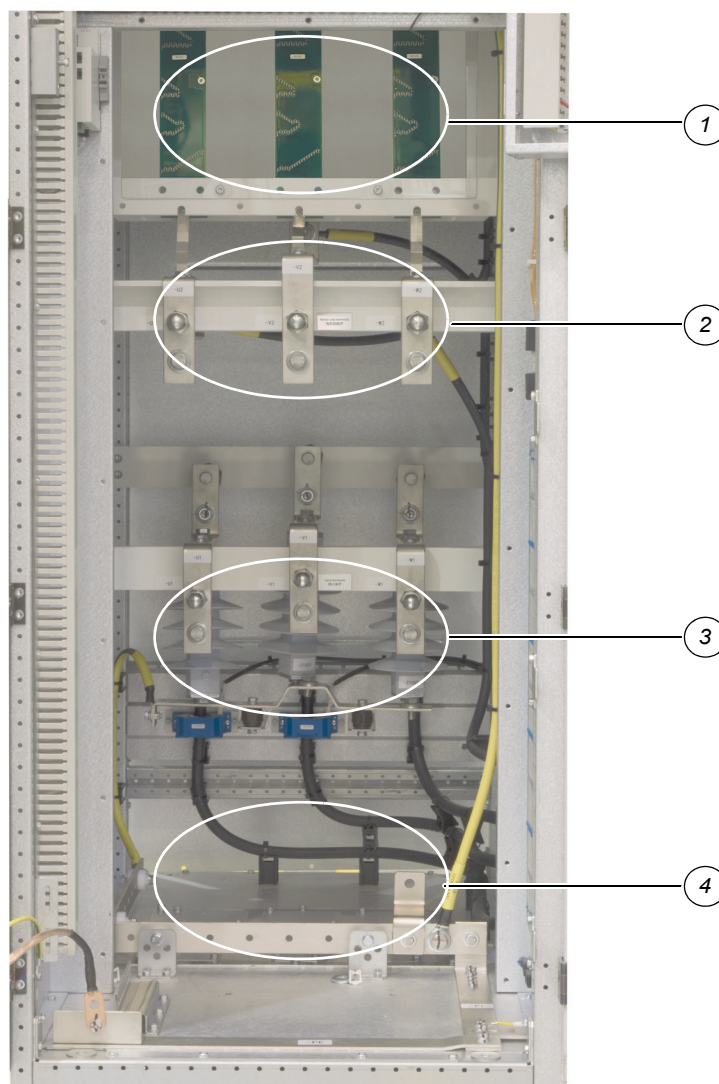

1	Voltage dividers
2	Motor side terminals
3	Input terminals
4	Cable entry plate (bottom plate)

Terminal compartment with cover plate removed, view from front.

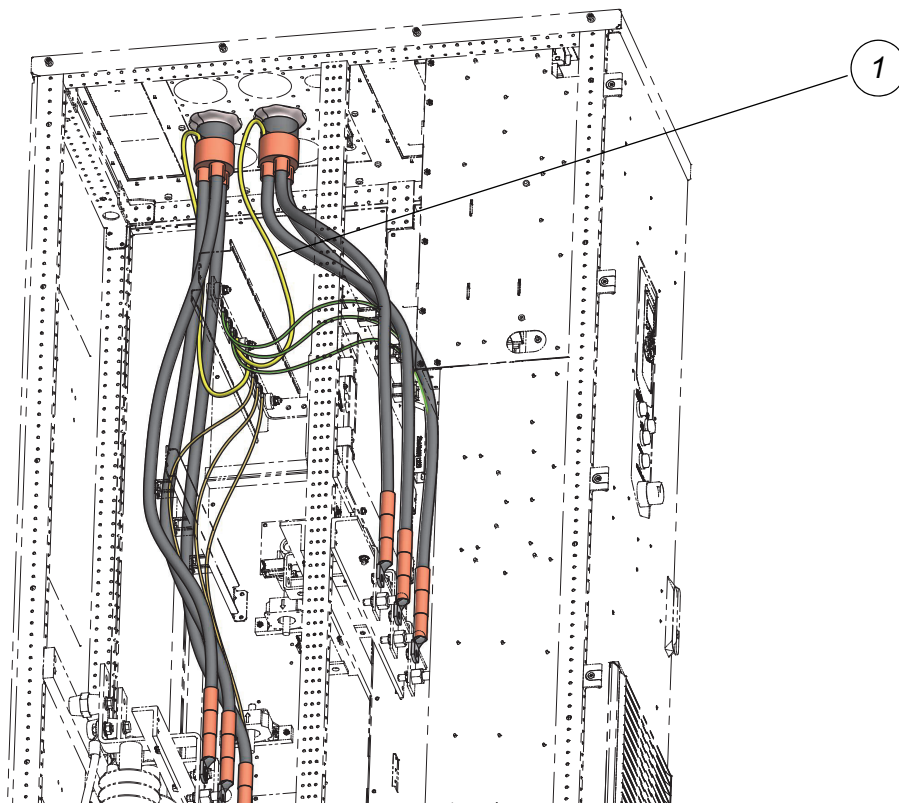

Side view: Power cable entry from top ((1) screen extensions to ground)

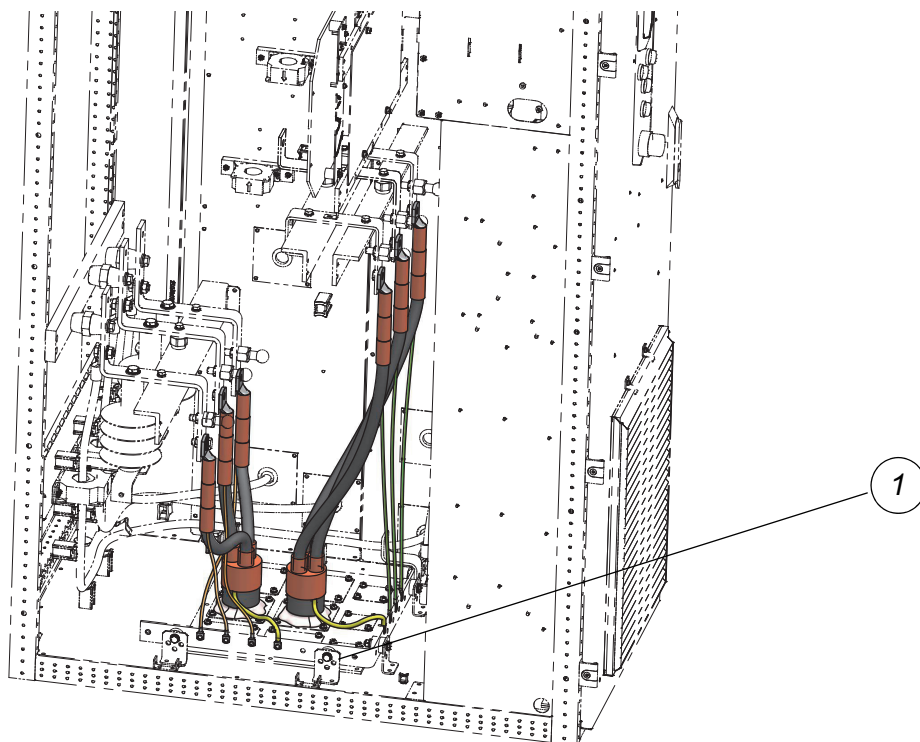

Side view: Power cable entry from bottom ((1) screen extensions to ground)

Installing auxiliary, control and serial communication cables

Route the cables as illustrated through the provided cable duct to the customer terminals or fieldbus modules in the control compartment. Pay attention to avoid auxiliary, control, serial communication cables mix together with power cables.

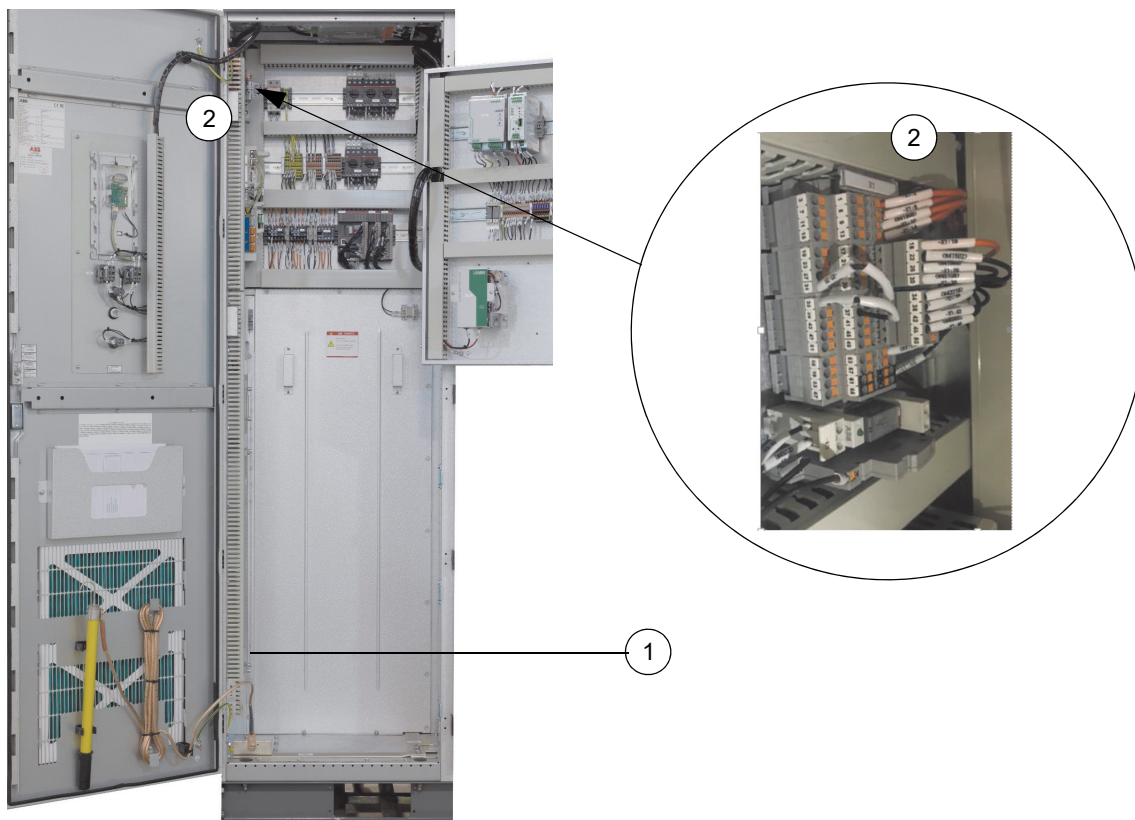

1	Duct for auxiliary and control cables
2	Customer terminals

Control and power supply cables for fan units

1. Route the control and power supply cables through one of the cable entries located in the floor of the fan unit. Choose either the front or the rear cable entry, according to the position of the fan cable connector.
2. Connect each cable to the appropriate connector.

NOTICE

The control and power supply cables are already prepared in the factory for connection.



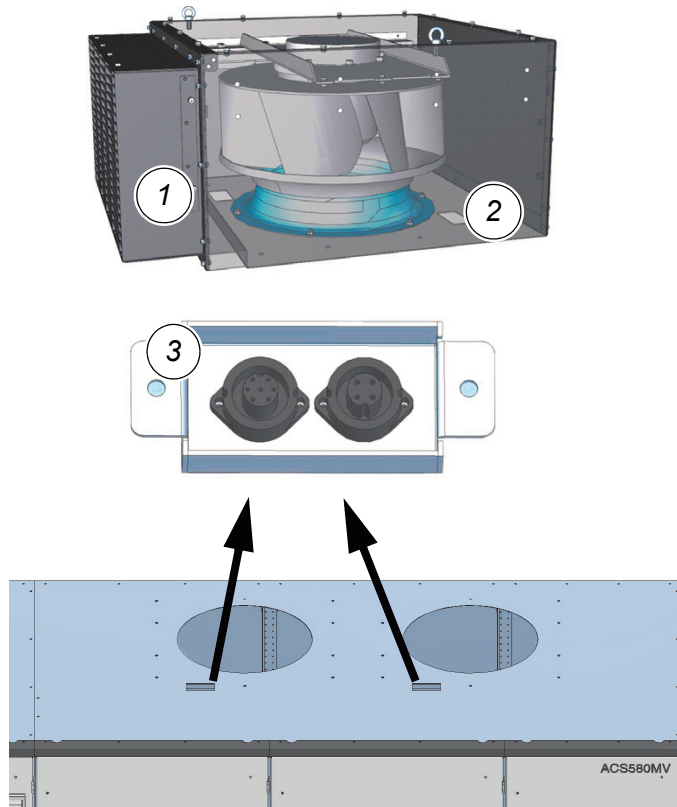

1	Front cable entry
2	Rear cable entry
3	Fan cable connectors

Sealing holes in entry plates

Sealing the gap between cable and entry plate are necessary. Recommend two component sealants below.

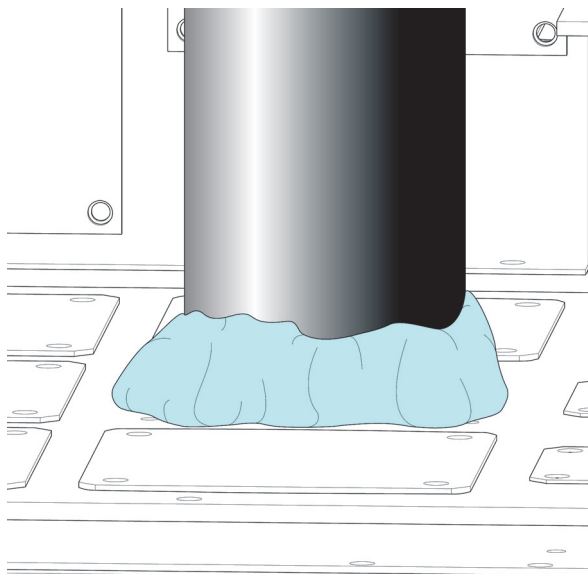

6

Installation checklist

Contents of this chapter

This chapter contains an installation checklist which you must complete before commissioning can take place.

Safety

**DANGER**

High voltage!

Obey the instructions in chapter [Safety instructions](#). If you ignore them, injury or death, or damage to the equipment can occur.

Before starting to work on the drive, make sure:

- that the main and auxiliary power supply to the drive is switched off, locked out, and tagged out
- that the drive is dead
- that safety ground connections are in place
- that personal protective equipment is provided and used when required
- that everyone involved is informed.

Before energizing the drive, make sure:

- that all foreign objects are removed from the drive
 - that all internal and external covers are securely fastened and all doors are closed, locked and / or bolted
 - that the release dials of safety switches are in the locked position.
-



WARNING! Obey the instructions in chapter [Safety instructions](#). If you ignore them, injury or death, or damage to the equipment can occur.



NOTICE! The field engineer should confirm that the power cables are connected to the correct bus bars before switching on the main power. Once the main power direct reach the output bus bars by wrong connections, the power modules would be irreversible damaged.

Checklist

Do the steps in section [Precautions before electrical work](#) on page 17 before you start the work. Go through the checklist together with another person.

Mechanical installation

1. The infrastructure of the electric room is finished and the installation site is sufficiently ventilated or cooled and dehumidification to ensure the converter can running at the appropriate temperature and humidity.
 2. The wall behind the unit is of non-flammable material. Please take the photo and send back.
 3. There is enough free space above the drive to enable cooling air flow, service and maintenance. See layout drawing. Please take the photo and send back.
 4. Ambient operating conditions meet the specifications given in chapter [Technical data](#)
 5. Drive installed according to the instructions in this manual (Chapters [Mechanical installation](#) and [Electrical installation](#))
 6. Drive securely fastened to the floor
 7. INU cabinet and transformer cabinet have finished combination.
 8. The floor that the unit is installed on is of non-flammable material, as smooth as possible, and strong enough to support the weight of the unit. Check the floor flatness with a spirit level. The maximum allowed deviation from the surface level is 5 mm in every 3 meters. Level the installation site, if necessary, as the cabinet is not equipped with adjustable feet.
 9. Fan units installed
-

10. Visual inspection:
- no badly affixed or damaged components
 - no foreign objects inside cabinet
 - no dirt, dust and humidity inside cabinet

Electrical installation

1. Types and cross-sections of control cables suitable for the signal type and signal level
2. Types and cross-sections of power cables selected according to the [ACS580MV Engineering Guideline](#)
3. Pulse encoder cable screens connected to **screen grounding point** and not connected directly to the pulse encoder interface (only applicable for drives with pulse encoder interface)
4. Internal cabling to integrated transformer (power, auxiliary, control and heater cables) made according to the instructions in this manual (Chapter [Electrical installation](#))
5. Cable entry made according to the instructions in this manual (Chapter [Electrical installation](#))
6. All control cable screens and conductors are connected according to the instructions in this manual (Chapter [Electrical installation](#)), appropriately labeled, and the customer-side connections are completed
7. Heating cable (if supplied) installed according to the instructions in this manual (Chapter [Electrical installation](#))
8. Ground cable of drive securely connected at both ends
9. Input and motor cables not connected at both ends (cables must be meggered before connection, drive optional - recommended in case of long storage time, humid environment or visible transportation damages)

Door interlocking

1. Door locks tested and in operation
2. The manual release of the door safety switch(es) is in the **locked** position.

Main circuit breaker (MCB)

1. Type of MCB selected as per [ACS580MV Engineering Guideline](#)
-

30 Installation checklist

2. High voltage connections completed
3. MCB ready to be tested with drive
4. MCB interposing relay settings tested
5. Local close order is disabled, and the connection to switch or button is canceled.
6. The wiring of the control & signal cables connecting with the converter is finished.
7. Safety devices checked and in operation
8. The user manual and technical specification is available.
9. Withstand voltage test of the MCB have been done according to Manufacture`s specifications. The official test report must be available.

Motor

1. Motor installed, aligned and alignment protocol available
2. Motor decoupled from driven load
3. Ground connection completed
4. Customer side motor protection set and ready (e.g. winding temperature, vibration)
5. Motor auxiliaries (e.g. bearing lubrication, heater cooling) ready
6. The user manual and technical specification is available.

Power cables

1. All cable screens are connected. Please take the photo and send back.
-

- 2. Grounding cables of transformer, converter and motor are connected and tighten.
- 3. Types and cross sections of power cables are selected according to the "ABB power cable specification". Type of cable_____
- 4. Transformer and motor cables are not fastened at both ends (cables and converter must be meggered before connection).

Insulation tests

- 1. All power cables to drive, and from drive to motor are meggered, and measured values are within the required limits.
- 2. Test report of the megger test available
Note: If the test is carried out by the commissioning engineer of the drive, an additional day per drive motor combination needs to be reserved. After the test, the feeder cables can be connected, except at the drive end. The test must comply with the specification.
- 3. Optional insulation tests of the drive are completed and documented. Insulation tests of the drive recommended in case: long storage time (>4 months), humid environment or visible damages due to transportation/installation.

Power supply

- 1. Medium voltage available for start-up of drive
- 2. Low voltage auxiliary power available for start-up of drive

Miscellaneous

- 1. Sufficient number and correct type of spare parts available
 - 2. Cooling of drive room ready for load run of drive
 - 3. Optional equipment ready
 - 4. Drive room properly dust filtered (dust filters at air inlet), see [ACS580MV Engineering Guideline](#)
-

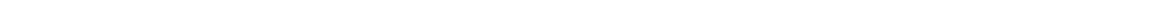



10

Operation

Status indications

The drive status is indicated with a status icon on the control panel.

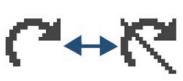
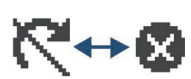
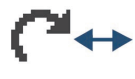
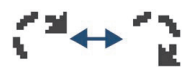
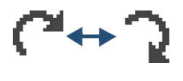
Status icon	Animation	Drive status
	-	Stopped
	-	Stopped, start inhibited
	Blinking	Stopped, start command given but start inhibited
	Blinking	Faulted
	Flashing	Running, at reference, but the reference value is 0
	Rotating	Running, not at reference
	Rotating	Running, at reference



Energizing and starting the drive

It is recommended to have the following documents at hand when starting the drive locally for the first time after commissioning:

- [ACS580MV Wiring Diagram](#)
- User's Manual "[ACS-AP-X assistant control panels user's manual](#)"

■ Checks before starting the drive



DANGER

Hazardous voltages!

All covers must be screwed in place to prevent unintentional contact with energized components.

The manual release of the door safety switches must be in the locked position. The locked position prevents doors of medium voltage compartments being opened unintentionally during operation.

When the drive is put into service after it has been commissioned, or after it has been taken out of service for maintenance or troubleshooting, check the drive according to the following list:

- Check that no tools and foreign objects are left inside the cabinets.
- Check that all auxiliary power supplies from external sources are switched on.
- Check that all internal circuit breakers of the drive are closed.
- Check that all grounding devices are removed
- Check that all covers are mounted and the doors are closed, locked and / or bolted.
- Check that the MCB is in **operating** position.
- Check that there is no run interlock active.

■ Starting the drive from remote

When the drive is operated from remote through a higher-level control system or an operator control desk, follow the instructions in the appropriate manuals.



■ **Starting the drive locally**

1. Enable the local control mode of the control panel by pressing the **Loc/Rem** key (1).

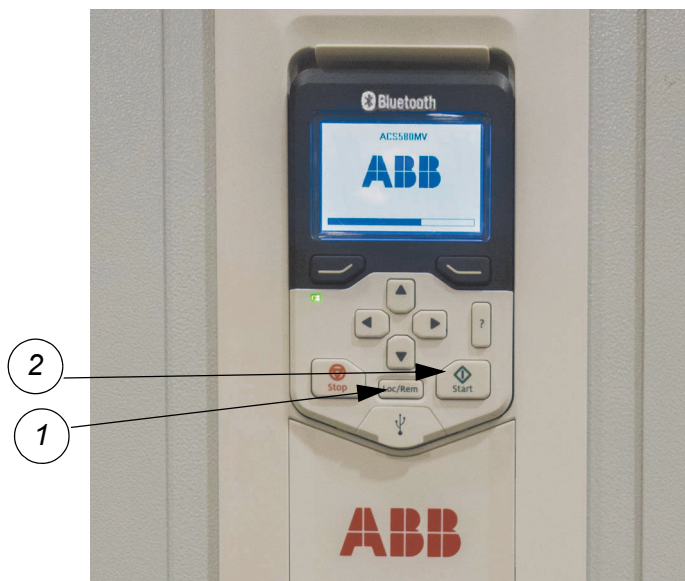

The drive is in state **Stopped** and the display shows  .

2. Press the **SUPPLY ON** pushbutton to connect the drive to the main power supply. The following takes place:
 - The MCB closes.
 - The DC link charges.

While the DC link charges, the **SUPPLY ON** pushbutton flashes. As soon as the DC link is charged, the **SUPPLY ON** pushbutton changes to a permanent light.

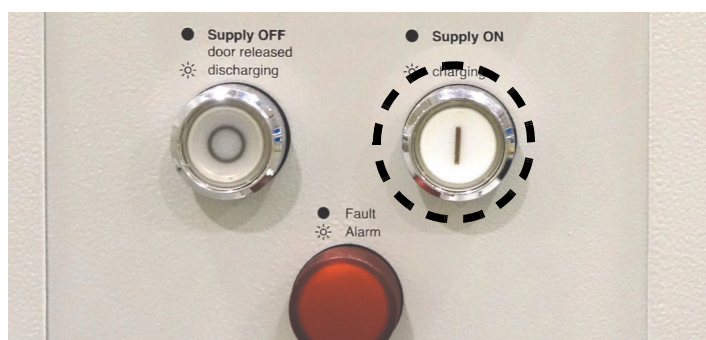

3. Enter the setpoint. See "[ACS-AP-X assistant control panels user's manual](#)"
4. Press the **Start** key (2) to start the motor.

After the motor has been magnetized, the motor speed ramps up to the setpoint.

While the motor is accelerating, the run status indication on the display blinks. When the motor speed has reached the setpoint, the run status indication lights up permanently.



Stopping the drive

This section describes how to stop the drive using the local operator panel of the drive. If the drive is remotely-controlled, follow the established shutdown procedures.

For details on using the local control panel see “[ACS-AP-X assistant control panels user’s manual](#)”.

1. Enable the local control mode of the control panel by pressing the **Loc/Rem** key (1).

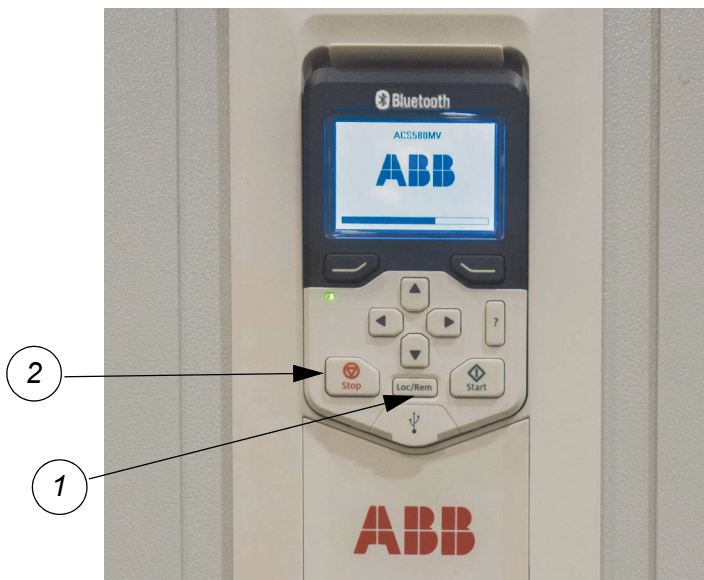

2. Press the **Stop** key (2).

The motor stops according to the preset stop function and the drive stops modulating. When the motor has reached zero speed, the drive is in state **Stopped** and the display shows .



DANGER

Hazardous voltages!

The ACS580MV is not de-energized in the state **Stopped**. Before doors are opened / removed or work is begun on the drive, the system must first be de-energized (see Chapter [Maintenance, Shutting down the drive for maintenance](#)).





Fault tracing

Contents of this chapter

The chapter lists the typical warning and fault messages including possible causes and corrective actions.

Warning and fault messages

In case of an alarm or fault refer to the [ACS580MV primary control program firmware manual](#) for the descriptions, causes and remedies of the drive control program warning and fault messages.

Code (hex)	Warning	Cause warning	What to do
A2B1	Overcurrent	Output current has exceeded internal alarm limit.	<p>Check motor load.</p> <p>Check acceleration times in parameter group 23 Speed reference ramp (rpm operation mode) or 28 Frequency reference chain (Hz operation mode).</p> <p>Also check parameters 46.01 Speed scaling and 46.02 Frequency scaling.</p> <p>Check motor and motor cable (including phasing and delta/star connection).</p> <p>Check there are no contactors opening and closing in motor cable.</p> <p>Check that the data in parameter group 99 Motor data corresponds to the motor rating plate.</p> <p>Check that there are no power factor correction capacitors or surge absorbers in motor cable.</p>
A2B4	Short circuit	Short-circuit in motor cable(s) or motor.	<p>Check motor and motor cable for cabling errors.</p> <p>Check that there are no power factor correction capacitors or surge absorbers in motor cable.</p>
A3D0	Grid ridethrough	Grid voltage is below the internal threshold so the drive is operating in low voltage ridethrough mode.	Check the transformer secondary voltage.
A5F4	Control unit battery	The battery of the control unit is low.	<p>Replace control unit battery. Refer to the HW manual for instructions on battery replacement.</p> <p>This warning can be suppressed using parameter 31.40.</p>
A7EE	Panel loss	Control panel or PC tool selected as active control location for drive has ceased communicating.	<p>Check PC tool or control panel connection.</p> <p>Check control panel connector.</p> <p>Disconnect and reconnect the control panel.</p> <p>Replace control panel in mounting platform.</p>
AFEB	Emergency OFF button pressed	Emergency OFF button on the cabinet door has been pressed.	<p>Check that it is safe to release the emergency OFF button on the front door and if it is, release the emergency OFF button.</p> <p>If the emergency OFF button is released but the warning is still active, check the wiring of the signals from the emergency OFF button.</p>

E204	Ambient temperature high	The air inlet temperature of the inverter unit is approaching the maximum converter ambient temperature.	Check and improve the cooling of the electric room where converter is placed.
E205	INU air pressure high	The air pressure drop across the inverter unit is approaching the limit value.	Check PM heatsinks for dust pick up and clean if required. Check pressure drop sensor on control hub and replace control hub if required.
E208	AC500 communication alarm	The watchdog supervision of the communication link between BCU and AC500 has detected a communication failure. Alarm is activated according to selection in parameter 50.32 FBA B comm loss func.	Check Modbus cable. Check FSCA-01 module. Check setting of parameter groups 54 FBA B settings, 55 FBA B data in and 56 FBA B data out (changes allowed only by ABB authorized personnel). Note: Make sure that up to maximum of two fieldbus extension modules are used on the BCU.
E218	INU door not closed	During charging of the drive, the inverter unit door lock has reported that the door is not locked.	Lock the inverter unit door. Check internal wiring of the door lock signals (open circuit, loose terminals). Check if fan is mechanically blocked or makes excessive noise (bearing problem).
E21E	Control backup supply failure	Control backup supply failure has been detected based on monitoring of the digital signal.	Check the control backup supply failure signal. Check setting of the parameter 81.11 Control backup supply monitoring.

Code (hex)	Fault	Cause	What to do
1010	Power module fault	A general PM fault has tripped the drive. A more detailed fault message with indication of which PM has a fault is followed to this message.	Check the more detailed fault message with the auxiliary code followed to this fault message. The code indicates which PM is affected.

40 Fault tracing

2110	Trafo overcurrent	The transformer primary current has exceeded internal fault limit.	<p>Check the event log for an auxiliary code. The code indicates the threshold which has been exceeded:</p> <p>0 - Transformer overcurrent 1 - Hardware overcurrent (95% of maximum measurable current)</p> <p>Check the primary cabling. Check the transformer. Contact your local ABB representative.</p>
211B	Grid current asymmetry	The difference between measured transformer primary currents has exceeded internal fault limit.	<p>Check the event log for an auxiliary code. The code indicates which value has exceeded the threshold:</p> <p>1 - Difference of phase A and B current RMS values 2 - Difference of phase B and C current RMS values 3 - Difference of phase C and A current RMS values</p> <p>Check for grid voltage asymmetry. Check the fault limit settings (Contact your local ABB representative).</p>
2340	Short circuit	Short-circuit in motor cable(s) or motor.	<p>Check motor and motor cable. Check that there are no power factor correction capacitors or surge absorbers in motor cable.</p>
3233	PM +5V power supply fault	The +5V power supply of a PM has failed.	<p>Check the event log for an auxiliary code. The code indicates which PM is affected. Replace the faulty PM.</p>
3236	PM DC link capacitors not balanced	The series connected capacitors in the DC link of a PM are heavily unbalanced.	<p>Check the event log for an auxiliary code. The code indicates which PM is affected. Replace the faulty PM.</p>
3239	PM diode open circuit	PM rectifier's diode open circuit is detected.	<p>Check the event log for an auxiliary code. The code indicates which PM is affected. Replace the faulty PM.</p>
3333	Ground fault	The common mode motor voltage of the drive has exceeded internal fault limit.	<p>Check for drive internal ground faults (secondary cabling, PMs, transformer, terminal unit). Check for drive external ground faults (motor cable, motor windings). Check the HVD board.</p>
4100	Ambient temperature	Ambient temperature is too high.	<p>Check for proper cooling of the control unit cabinet.</p>
5012	PM HB1 or HB2 short circuit turn off	The desaturation detection of the IGBTs in HB1 (half bridge 1) or HB2 (half bridge 2) of a PM has detected a short circuit.	<p>Check the event log for an auxiliary code. The code indicates which PM is affected. Check converter output terminals for a phase to phase short circuit. Replace the faulty PM.</p>

7538	Control hub missing PM	A PM in the converter does not send data to the control hub (PM Tx channel fault).	Check the event log for an auxiliary code. The code indicates which PM is affected. Check POF wiring to the PM (or replace). Check control hub daughter board (or replace). Replace the PM
E108	AC500 communication fault	The watchdog supervision of the communication link between BCU and AC500 has detected a communication failure.	Check Modbus cable. Check FSCA-01 module. Check setting of parameter groups 54 FBA B settings, 55 FBA B data in and 56 FBA B data out (changes allowed only by ABB authorized personnel). Note: Make sure that up to maximum of two fieldbus extension modules are used on the BCU.
E114	MCB control fault	MCB close command and MCB close feedback do not match.	Check if MCB has tripped on its own, by means of short circuit protection relay or overload protection relay and adapt MCB protection relay settings if required. Check MCB control wiring between ACS580MV and MCB



REPLACE THE MEMORY UNIT AND SD CARD

Replacing the memory unit



WARNING! Do not remove or insert the memory unit when the control unit is powered.

See B in figure [Replacement illustration](#) on page 42.

1. To remove the memory unit, undo the fastening screw and pull the memory unit out.
See the following figure.
2. Insert the new memory unit and fasten the screw.

Replacing SD card

Note: Do not remove the SD card while the yellow WRITE LED is lit. Writing to the SD card is in progress.

See C in figure [Replacement illustration](#) on page 42.

1. Undo the fastening screw of the clip covering the memory card and press the card to remove it. For the card location, see the following figure.
2. Insert the new card in reverse order.



44 replace the memory unit and Sd card

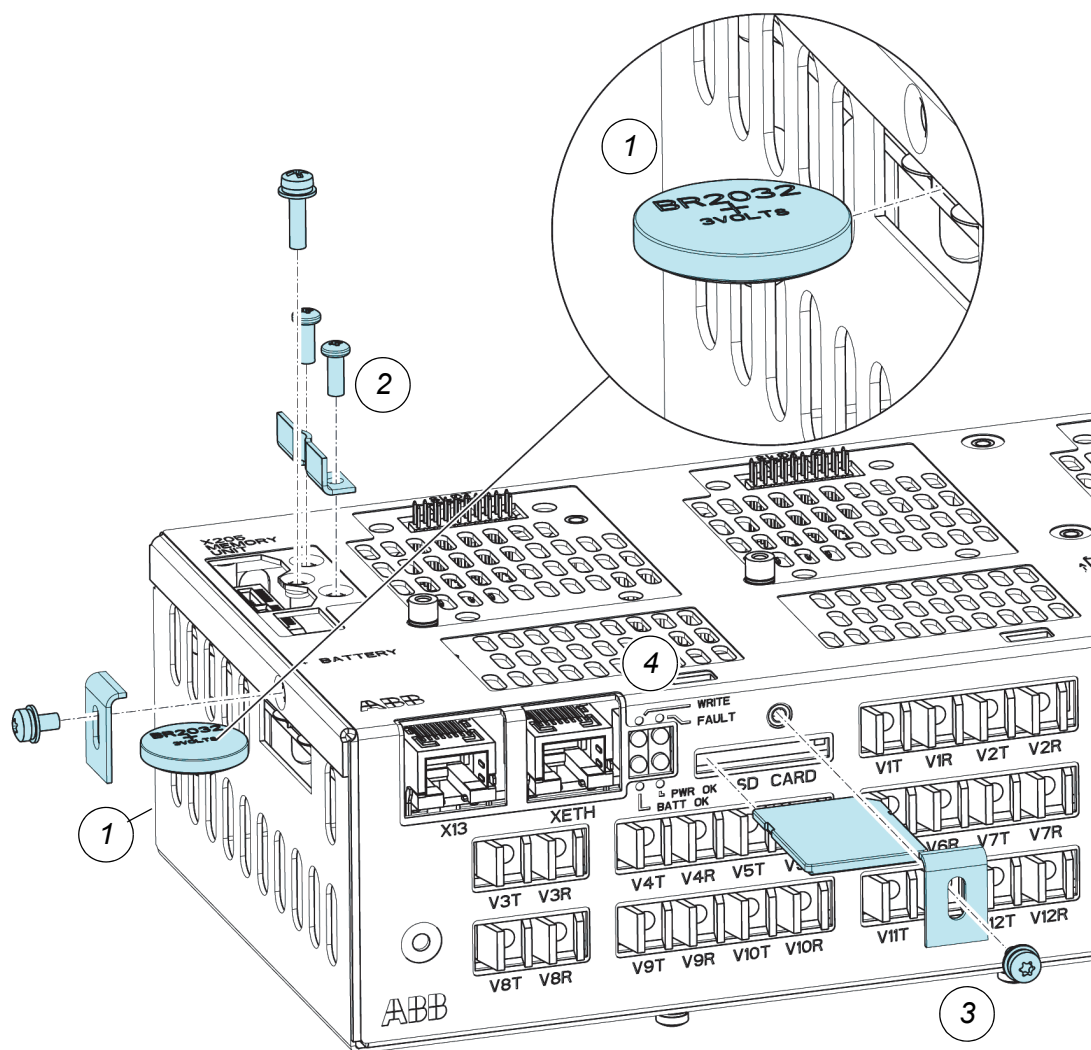

1	Real-time clock battery
2	Fastening screws for ZMU
3	Fastening screw for SD card
4	Indication LEDs



Further information

Product and service inquiries

Address any inquiries about the product to your local ABB representative, quoting the type designation and serial number of the unit in question. A listing of ABB sales, support and service contacts can be found by navigating to abb.com/searchchannels.

Product training

For information on ABB product training, navigate to new.abb.com/service/training.

Providing feedback on ABB Drives manuals

Your comments on our manuals are welcome. Navigate to new.abb.com/drives/manuals-feedback-form.

Document library on the Internet

You can find manuals and other product documents in PDF format on the Internet at abb.com/drives/documents.



abb.com/drives

